

**PUBLIC UTILITY DESIGN AND
CONSTRUCTION SPECIFICATIONS**

for

**WATER DISTRIBUTION
and
WASTEWATER COLLECTION**

DONALA WATER & SANITATION DISTRICT

15850 Holbein Drive
Colorado Springs, CO 80921

Ph (719) 488-3603

Prepared by

DONALA WATER & SANITATION DISTRICT

and

GMS, INC. CONSULTING ENGINEERS
611 North Weber, Suite 300
Colorado Springs, CO 80903



DONALA WATER AND SANITATION DISTRICT

PUBLIC UTILITY DESIGN AND CONSTRUCTION SPECIFICATIONS

FOR WATER DISTRIBUTION AND WASTEWATER COLLECTION

		Date of Original Issue	Date of Latest Revision
Part I	Water System Standard Specifications	2/15/94	5/12/06
Part II	Wastewater Collection System Standard Specifications	2/15/94	8/10/99
Part III	Earthwork Standard Specifications	2/15/94	5/15/96
Part IV	Water System Standard Specifications	2/15/94	4/30/2019

PART I

WATER SYSTEM STANDARD SPECIFICATIONS

TABLE OF CONTENTS

CHAPTER 1 - GENERAL

<u>Section</u>	<u>Title</u>	
1.01	Authority	I-1-1
1.02	Effective Date of Specifications.....	I-1-1
1.03	Revisions, Amendments or Additions	I-1-1
1.04	District Control.....	I-1-1
1.05	Organization and Interpretation of Specifications	I-1-1
1.06	Definitions	I-1-1
1.07	Abbreviations	I-1-2

CHAPTER 2 - MAIN EXTENSIONS

<u>Section</u>	<u>Title</u>	
2.01	Extensions Defined	I-2-1
2.02	Standard Specifications to Apply	I-2-1
2.03	Responsibility for Main Extensions.....	I-2-1
2.04	Application Procedure	I-2-1
2.05	Plan Requirements for Water System Extensions.....	I-2-2
2.06	Plan and Profile Drawings.....	I-2-6
2.07	Conflicts Between Plans and Specifications	I-2-7
2.08	Construction Procedure	I-2-7
2.09	Surveying	I-2-8
2.10	Placing Survey Lines.....	I-2-8
2.11	Notice of Field Staking and Construction by the Developer	I-2-8
2.12	Inspection.....	I-2-8
2.13	Performance Agreement and Bill of Sale.....	I-2-9
2.14	Special Conditions	I-2-10

CHAPTER 3 - DISTRIBUTION SYSTEM DESIGN AND LAYOUT

<u>Section</u>	<u>Title</u>	
3.01	General	I-3-1
3.02	Quality of the Distribution System	I-3-1
3.03	Sizing of Distribution Mains	I-3-1
3.04	Fire Protection	I-3-1
3.05	Distribution Regulation Installations	I-3-2
3.06	Pumping Facilities	I-3-3
3.07	Storage Facilities.....	I-3-3
3.08	Layout of the Distribution System	I-3-3
3.09	Line Valves.....	I-3-4
3.10	Connections to Mains for Fire Sprinkler Lines.....	I-3-4
3.11	Clearance and Encasement Design for Sanitary and Storm Sewer Crossings	I-3-4

CHAPTER 4 - MATERIALS

<u>Section</u>	<u>Title</u>	
4.01	Materials and Testing.....	I-4-1
4.02	Size of Mains.....	I-4-1
4.03	Distribution System Piping	I-4-1
4.04	Pipe Fittings	I-4-3
4.05	Steel Pipe and Fittings	I-4-3
4.06	Gate Valves.....	I-4-4
4.07	Valve Boxes	I-4-5
4.08	Fire Hydrants.....	I-4-6
4.09	Corrosion Protection Systems.....	I-4-7
4.10	Concrete Thrust Blocks, Anchors and Structures	I-4-8
4.11	Mechanical Joint Restraint	I-4-9
4.12	Casing Pipe.....	I-4-10
4.13	Responsibility for Materials	I-4-10
4.14	Handling of Materials	I-4-10
4.15	Pressure Regulation Valves and Accessories	I-4-11

CHAPTER 5 - PIPE INSTALLATION

<u>Section</u>	<u>Title</u>	
5.01	Approval by the District	I-5-1
5.02	Handling of Materials	I-5-1
5.03	Inspection and Preparation of Pipe and Fittings	I-5-1
5.04	Cutting and Fitting of Pipe.....	I-5-1

CHAPTER 5 - PIPE INSTALLATION (continued)

<u>Section</u>	<u>Title</u>	
5.05	Pipe Joint Lubrication	I-5-1
5.06	Pipe Alignment and Grade	I-5-1
5.07	Deviation from Alignment and Grade Occasioned by Other Structures.....	I-5-2
5.08	Temporary Bulkheads	I-5-2
5.09	Frost	I-5-2
5.10	Excavation, Bedding and Backfill	I-5-2
5.11	Lowering of Material into the Trench	I-5-3
5.12	Laying of Pipe	I-5-3
5.13	Ductile Iron Pipe	I-5-3
5.14	Polyvinyl Chloride Pressure Pipe	I-5-5
5.15	Installation of Valves	I-5-5
5.16	Valve Boxes	I-5-6
5.17	Installation of Fittings	I-5-6
5.18	Fire Hydrants.....	I-5-6
5.19	Dead Ends and Blow Offs	I-5-7
5.20	Thrust Blocks and Anchors	I-5-8
5.21	Vaults	I-5-9
5.22	Harness Rods	I-5-9
5.23	Bridging and Encasement of Pipe.....	I-5-9
5.24	Encasement or Sleeve Pipe.....	I-5-11
5.25	Connections to the District's System.....	I-5-11
5.26	Corrosion Protection Systems.....	I-5-11
5.27	Disinfection.....	I-5-12
5.28	Pressure Testing.....	I-5-13
5.29	Acceptance and Release for Taps.....	I-5-13
5.30	Acceptance of Mains and Service Lines Including Curb Stops.....	I-5-14

CHAPTER 6 - SERVICE LINES

<u>Section</u>	<u>Title</u>	
6.01	All New Service Lines and, Where Applicable, Service Line Replacements	I-6-1
6.02	Water Service Line Excavations for All New and Replacement Service Lines.....	I-6-2
6.03	Service Line Installation and Material for All New and Replacement Service Lines	I-6-3
6.04	Curb Stop and Curb Box for All New and Replacement Service Lines.....	I-6-4

CHAPTER 6 - SERVICE LINES (continued)

<u>Section</u>	<u>Title</u>	
6.05	Water Meters - General	I-6-5
6.06	Inside Water Meter Installations Only	I-6-5
6.07	Water Meter Pit Installations Only.....	I-6-6
6.08	Combined Domestic and Fire Line Water Meters	I-6-6
6.09	Remote Readers.....	I-6-7
6.10	Water Regulators.....	I-6-7
6.11	Inspection of Services for All New and Replacement Service Lines.....	I-6-7
6.12	Repair and Replacement of Existing Service Lines	I-6-8

CHAPTER 7 - WATER SERVICE QUALITY CONTROL REGULATIONS

<u>Section</u>	<u>Title</u>	
7.01	General	I-7-1
7.02	Cross Connection Control & Backflow Prevention - Criteria List.....	I-7-6

STANDARD DRAWINGS

<u>No.</u>	<u>Title</u>
W-1	Typical Utilities Location
W-2	Typical Water Plan - District Mains
W-3	Typical Water Plan - Private Mains
W-4	Fire Hydrant Locations
W-5	Fire Hydrant Installation
W-6	Fire Hydrant Specifications
W-7	Valve Installation and Location
W-8	Valve Box Installation
W-9	Polyethylene Wrap
W-10	Bonding Joint and Anode Installation
W-11	Insulator Installation
W-12	Copper Tracer Wire on PVC Service
W-13	Thrust Block Data
W-14	Thrust Blocks Required for Taps
W-15	Typical Trench Cross Section
W-16	Maximum Pipeline Deflection Data
W-17	Pipe Cutting

STANDARD DRAWINGS (continued)

<u>No.</u>	<u>Title</u>
W-18A	Reverse Anchor Detail
W-18B	Reverse Anchor Detail
W-19	Concrete Pipe Encasement Detail
W-20	Water Line Lowering Detail
W-21	Pipe Bridging Detail
W-22	Temporary and Permanent Blow Off Assemblies for 6" and 8" Mains
W-23	Temporary and Permanent Blow Off Assemblies for 12-inch and Larger
W-24	Blow-Off Assembly Dimension Data for 12-inch or Larger
W-25	Pipe Tapping Detail
W-26	Flange Lug Detail
W-27	Applications for Mechanical Joint Restraints
W-28	Restrained M.J. Pipe Length Data
W-29	12-Inch Check Valve Station
W-30	Pressure Relief Station
W-31	8-Inch Size Pressure Regulator Station
W-32	6-Inch Size Pressure Regulator Station
W-33	2" Air and Vacuum Valve Station
W-34	Standard Concrete Vault for Valve Installations - Precast
W-35	Standard Concrete Vault for Valve Installations - Cast-in-Place Concrete
W-36	Protecting Tie-Rods
W-37	Taping Detail - 3/4" thru 2"
W-38	Typical Installation for Service Line, Stop Box and Meter
W-38A	Typical Service Line Trench - Common Ditch for Water or Sewer
W-39	Water Meter Loop for 3/4" thru 1" Meters
W-40	New Service Line/Water Pit Installation
W-41	Irrigation Service 3/4" and 1" Meter Installation
W-42	1½" and 2" Irrigation Meters

PART II

WASTEWATER COLLECTION SYSTEM STANDARD SPECIFICATIONS

TABLE OF CONTENTS

CHAPTER 1 - GENERAL

<u>Section</u>	<u>Title</u>	
1.01	Authority	II-1-1
1.02	Effective Date of Specifications.....	II-1-1
1.03	Revisions, Amendments or Additions	II-1-1
1.04	District Control.....	II-1-1
1.05	Organization and Interpretation of Specifications	II-1-1
1.06	Definitions	II-1-1
1.07	Abbreviations	II-1-2

CHAPTER 2 - DESIGN PROVISIONS

<u>Section</u>	<u>Title</u>	
2.01	Planning Considerations	II-2-1
2.02	Minimum Size.....	II-2-1
2.03	Minimum Depth	II-2-1
2.04	Minimum Slopes.....	II-2-2
2.05	High Velocity Protection	II-2-2
2.06	Alignment	II-2-2
2.07	Pipe Alignment in Manholes.....	II-2-3
2.08	Manhole Location	II-2-3
2.09	Manhole Details	II-2-3
2.10	Relation to Water Mains.....	II-2-5
2.11	Stream and Drainage Channel Crossings.....	II-2-6
2.12	Railroad and Highway Crossings	II-2-6
2.13	Service Lines (Building Sewers).....	II-2-7
2.14	Pump Station Design Parameters.....	II-2-7
2.15	Sanitary Sewerage Plan Submittal Requirements	II-2-8
2.16	Sewage System and Trench and Foundation Drains.....	II-2-9

CHAPTER 3 - PIPE AND MANHOLE MATERIALS

<u>Section</u>	<u>Title</u>	
3.01	PVC Pipe and Fittings (Polyvinyl Chloride)	II-3-1
3.02	Ductile Iron Pipe	II-3-2
3.03	Manholes.....	II-3-3
3.04	Cast-in-Place Concrete	II-3-4
3.05	Castings	II-3-4
3.06	Steps	II-3-5
3.07	Cement Mortar	II-3-5
3.08	Cement Grout	II-3-5
3.09	Non-Shrink Grout	II-3-5
3.10	Dampproofing Material.....	II-3-5

CHAPTER 4 - PIPE INSTALLATION

<u>Section</u>	<u>Title</u>	
4.01	Subgrade Preparation	II-4-1
4.02	Pipe Laying	II-4-1
4.03	Fittings, Couplings, Wyes and Saddles	II-4-1
4.04	Service Lines.....	II-4-2
4.05	Manholes.....	II-4-3

CHAPTER 5 - TESTING OF PIPELINES AND APPURTENANCES

<u>Section</u>	<u>Title</u>	
5.01	Infiltration.....	II-5-1
5.02	Air Test.....	II-5-1
5.03	Alignment Testing	II-5-2
5.04	Deflection Tests	II-5-3
5.05	Internal Video Inspection.....	II-5-3

STANDARD DRAWINGS

<u>No.</u>	<u>Title</u>
WW-1	Pipe Bedding
WW-2	Typical Trench Cross Section
WW-3	Precast Manhole
WW-4	Sanitary Sewer Manhole
WW-5	Sanitary Sewer - Drop Manhole
WW-5A	Sanitary Sewer - Drop Manhole
WW-6	Manhole with Underdrain
WW-7	Manhole Ring and Cover Adjustment
WW-8	Sanitary Sewer Main Clean-out
WW-9	Sanitary Sewer Service Connection

WW-10 Pipe Encasement
STANDARD DRAWINGS (continued)

<u>No.</u>	<u>Title</u>
WW-11	Typical Utilities Location
WW-12	Pipe Bridging
WW-13	Shallow Sanitary Sewer Line Protection/Encasement
WW-14	Pipe Cutting
WW-15	Polyethylene Pipe Wrap
WW-16	Cadweld/Anode Connection
WW-17	Maximum Pipeline Deflection Data
WW-18	Grease Interceptor
WW-19	Sand/Oil Separator
WW-20	Grease Separator = 250 lbs.
WW-21	Grease Separator = 500 lbs.
WW-22	Kor-n-Seal Boot Detail

PART III
EARTHWORK STANDARD SPECIFICATIONS
TABLE OF CONTENTS

CHAPTER 1 - GENERAL

<u>Section</u>	<u>Title</u>	
1.01	Authority	III-1-1
1.02	Effective Date of Specifications.....	III-1-1
1.03	Revisions, Amendments or Additions	III-1-1
1.04	District Control.....	III-1-1
1.05	Organization and Interpretation of Specifications	III-1-1
1.06	Definitions	III-1-1
1.07	Abbreviations	III-1-2

CHAPTER 2 - TRENCHING, BACKFILLING AND COMPACTING

2.01	General Provisions.....	III-2-1
2.02	Job Conditions	III-2-2
2.03	Guarantee	III-2-4
2.04	Products.....	III-2-5
2.05	Preparation of Trenching	III-2-6
2.06	Excavation - Open Cut.....	III-2-7
2.07	Pipe Embedment	III-2-10
2.08	Trench Backfilling and Compacting	III-2-11
2.09	Backfill for Structures	III-2-12
2.10	Field Quality Control.....	III-2-12
2.11	Surface Restoration	III-2-13
2.12	Surface Improvement Repair and Restoration.....	III-2-13
2.13	Cleanup.....	III-2-14

PART I

WATER SYSTEM STANDARD SPECIFICATIONS

Chapter 1 - General

- 1.01 Authority. These Specifications are promulgated by the Donala Water and Sanitation District. The interpretation, enforcement, and revision of these Specifications is hereby delegated to the General Manager of the District.
- 1.02 Effective Date of Specifications. These Specifications shall be in effect fifteen (15) calendar days after adoption by the District Board and shall supersede all former standard specifications for installation of water mains within the Donala Water and Sanitation District.
- 1.03 Revisions, Amendments or Additions. These Specifications may be revised, amended or added to. Such revisions, amendments and additions shall be binding and in full force and effect when adopted in the manner set forth in Section 1.02.
- 1.04 District Control. These Specifications will apply to the installation, operation and maintenance of all distribution facilities under the control of the Donala Water and Sanitation District.
- 1.05 Organization and Interpretation of Specifications. These Specifications are composed of written Standards of Engineering Practice, Material Specifications and Standard Drawings. The interpretation of any section or of differences between sections, when appropriate, shall be made by the General Manager of the District and his/her interpretation shall be binding and controlling in its application.
- 1.06 Definitions. As used in these Specifications, or in any of the drawings where these Specifications govern, unless the context shall otherwise require, the following words defined shall have the meanings herein ascribed:
- a. Donala Water and Sanitation District. The Donala Water and Sanitation District, organized and operated under the statutes of the State of Colorado is a Special District providing public water and wastewater service within its service area.
 - b. General Manager. The General Manager of the District or his/her designated representative.
 - c. Engineer. The Engineer or consultant of the District, acting either directly or through properly authorized agents, such agents acting within the scope of the particular duties entrusted to them.
 - d. Distribution System. Mains, together with all appurtenant and necessary valves, hydrants, taps, meters, service pipes, and associated materials, property and equipment distributing potable water to individual customers.
 - e. Water Main or Distribution Main. That portion of the water supply system which transmits and distributes water of the District from treatment or storage facilities to users, excluding service lines.
 - f. Service Line. The water line extending from the premises up to and including the connection to

the distribution main.

- g. Applicant for System Extension. Any person, association, corporation, entity, or government agency desiring water service for premises under their control, often a subdivider, a developer or an owner.
- h. Main Extension. Extensions to the existing water distribution network.
- i. Contractor. In the context of these Specifications a person or persons, co-partnership or corporation employed by an applicant for the purpose of installing water system extensions or replacements.
- j. Inspector. The authorized representative of the District assigned to the project.
- k. Standard Drawings. District Standard Drawings are a part of these Specifications.

1.07 Abbreviations. All references to documents or specifications shall be the latest edition or revision thereof:

- a. ASTM American Society for Testing and Materials
- b. AWWA American Water Works Association
- c. ANSI American National Standards Institute
- d. NSF National Sanitation Foundation
- e. OSHA Occupational Safety and Health Act
- f. USGS United States Geological Survey
- g. CIP Cast Iron Pipe
- h. DIP Ductile Iron Pipe
- i. PVC Polyvinyl Chloride Plastic Pipe
- j. psi Pounds per Square Inch
- k. PPM Parts per Million
- l. PRV Pressure Reducing Valve

WATER SYSTEM STANDARD SPECIFICATIONS

Chapter 2 - Main Extensions

- 2.01 Extensions Defined. Distribution system extensions within the Donala Water and Sanitation District are referred to as "Main Extensions." "Main Extensions" shall further be defined as "District Mains" and "Private Mains."
- a. District Mains. Main extensions as designated by the District to be located within public rights-of-way and/or easements as determined by the District. These mains and appurtenances shall be owned and maintained by the Donala Water and Sanitation District.
- b. Private Mains. Main extensions as designated by the District to be located outside of public rights-of-way and/or easements. These mains shall be owned and maintained by an individual, property owner(s), corporation, home owners association or partnership.
- Private mains shall be limited to mains required for fire protection unless determined otherwise by the District. See Section 3.04 of these Specifications.
- 2.02 Standard Specifications to Apply. These Standard Specifications shall apply uniformly to both "District Main" and "Private Main" extensions subject only to some appurtenance and procedural variations.
- 2.03 Responsibility for Main Extensions. All water main extensions within the Donala Water and Sanitation District and El Paso County or total service areas shall be made at the expense of the developer or owner. Extensions shall be made from the nearest adequate source to a point or points of the property line, farthest from the existing distribution main, on the frontage of the applicants property or to a point of tie-in to an existing main as designated by the District. The District shall determine the size of main, location and required appurtenances, and the District's determination of size, location, appurtenances and point(s) of extension of water mains shall be final. See Sections 3.03 and 7.02 of these Specifications.
- 2.04 Application Procedure. All inquiries, applications and submission of plans for water main installations shall be initiated through the Donala Water and Sanitation District, General Manager of the District, 15850 Holbein Drive, Colorado Springs, CO 80921.

The District will establish, and may amend from time to time, procedures to be followed by applicants for "Private Mains." These procedures shall include all requirements for paperwork, submittals, engineering design, construction and acceptance. The engineering design and water plan portions of the extension applications shall include the following considerations:

For "District Main" Extensions Only. An initial submittal by the applicant including an overall or master plan showing the area to be developed and any other adjoining proposed developments by the Owner/Developer. Large or difficult areas may require extensive study and analysis.

The District will return to the applicant its requirements for:

- a. Points of connection to existing facilities.
- b. Size of mains to be installed.
- c. Locations of mains to be installed.
- d. Special features such as pressure regulating valves, blow offs, relief valves, booster pumps, etc.
- e. Acceptable materials.

For Both "District Main" Extensions and "Private Main" Extensions. The applicant shall submit final plans prepared by a Professional Engineer in three copies for checking by the District. This submittal shall contain all of the items enumerated in the procedures as established in Section 2.05 of these Specifications.

The District shall check all submittals for conformance with these Standard Specifications and other applicable rules and regulations and either approve the submittal or return it to the applicant for correction.

All final plans shall be approved by the Owner and/or Developer prior to submittal to the District.

- 2.05 Plan Requirements for Water System Extensions. Detailed plans for system extensions shall be prepared for approval with the submittal to the District. All plans submitted shall be in strict compliance with the Standards contained herein and shall meet special conditions that may be reasonably required.

The design and installation of all facilities shall insure development of an integrated water system. No work shall commence on any facilities until the plans for construction are approved in writing by the General Manager.

When a District water main is to be installed outside of the public street right-of-way, within an easement or right-of-way dedicated for water main installations, the Owner/Developer shall be responsible to provide restoration and landscaping adequate to prevent erosion caused by surface run-off. Landscaping and restoration construction shall be designed in such a manner that minimum future maintenance will be required. A landscaping and restoration design plan shall be submitted with the water plan for approval and will be subject to the same guarantee as described in Section 2.13 of these Specifications.

All proposed District water mains to be installed within a dedicated water line easement or right-of-way will require plan and profile drawings to be prepared by the Owner/Developer's engineer and approved by the District.

Final plans should not be submitted for work that will not be installed within six months of the approval date. All final plans shall contain, but are not limited to, the following information: See Standard Drawings No. 2 and 3.

Plan view containing or showing:

- a. A recorded plat showing location and dimensions of dedicated street, alleys, rights-of-way and easements.
- b. Lots and blocks.
- c. All existing and proposed curb and gutter.
- d. Sidewalk locations with respect to property lines.
- e. All existing or proposed utilities which may conflict with water installations to include size, type and horizontal and vertical location.
- f. All existing or proposed obstructions such as vaults, catch basins, traffic islands, etc.
- g. The proposed alignment and size of the water lines to include the location of all proposed facilities such as valves, hydrants, fittings, etc.
- h. Private service taps larger than 2 inches to include location and size.

Additionally, all plans shall:

- a. Be made from actual field surveys referenced to land corners or other official survey control points and be of sufficient accuracy so that the facilities can be accurately staked for installation and can be readily located after installation for maintenance, tapping and control.
- b. Be of suitable scale to show all necessary information. Larger scales shall be used when necessary to adequately show specific details of mains, connections and other installations.
- c. Show sufficient adjacent area to give the relationship of new facilities to existing facilities.
- d. Be neat, orderly and legible. Sloppy, smeared, or nonconforming plans shall be rejected. See Standard Drawings No. 2 and 3.
- e. Require the following statements and signature blocks for "District" and "Private" main extensions.

Tests for corrosive soil conditions may be required by the District. If so required, said tests shall:

- a. Be required prior to all proposed water line installations.
- b. Be performed by the Applicant.
- c. Require that the area of water main installation be graded to subgrade prior to testing.
- d. Determine if protection of water installations will be required in conformance with Section 5.25 of these Specifications.

DISTRICT MAIN EXTENSIONS

Water Statement

The undersigned Owner/Developer agrees that the installation of these proposed water facilities will be made in accordance with Donala Water and Sanitation District Specifications and shall provide a minimum of 5 feet and a maximum of 6 feet of cover over the water main(s). Any changes required to meet the above stipulations shall be at the expense of the Owner/Developer. Cover in excess of 8 feet shall be supported by plan and profile drawings approved by the District.

Signed _____ Date _____
Owner/Developer

DBA _____

Address _____

All hydrants shall be installed according to the District's Specifications.

Water Installation Corrosion Control Requirements

None required

Required, described as follows:

Water Plan Approval

Signed _____ Date _____
Donala Water and Sanitation District

PRIVATE MAIN EXTENSIONS

Water Statement

The undersigned Owner/Developer agrees that the installation of these proposed water facilities will be made in accordance with Donala Water and Sanitation District Specifications and shall provide a minimum of 5 feet and a maximum of 6 feet of cover over the water main(s). The undersigned understands that all water mains, fire hydrants and appurtenances as indicated on this water installation plan shall remain the property of the Owner and shall be maintained by the Owner.

Signed _____ Date _____
Owner/Developer

DBA _____

Address _____

All fire hydrants shall be installed according to the District's Specifications.

Water Installation Corrosion Control Requirements

None required

Required, described as follows:

Water Plan Approval

Signed _____ Date _____
Donala Water and Sanitation District

2.06 Plan and Profile Drawings. Plan and profile drawings shall be provided for all 12-inch and larger water mains and for water mains less than 12-inch when deemed necessary by the District. All plan and profile drawings for water mains shall be prepared at the expense of the Owner and/or Developer.

Plan and profile drawings for 12-inch and larger mains prepared by a consulting firm or individual shall bear the name and registration number of a Registered Professional Engineer in the State of Colorado.

The scale for all plan and profile drawings shall be 1" = 50' horizontal and 1" = 5' vertical.

Additional specifications added to plan and profile drawings shall be in addition to, and shall supersede these Specifications.

Three (3) copies of all plans and specifications for facilities to be installed under these rules and regulations shall be furnished to the District. One (1) copy will be returned to the applicant when approved by the District and bear evidence of such approval or comments requiring correction.

Design Information Required. Prior to beginning a plan and profile design for a water main 12-inch or larger, the Developer or his/her agent shall be required to submit the following information to the District:

- Approved Water Plan
- Recorded Subdivision Plat
- Approved Storm Drain and Street Plan
- Approved Wastewater Plan

Along with the above shall be included:

- Horizontal and vertical location of all existing and proposed utilities and structures which may conflict
- Curve Data
- USGS elevations and bench marks with a location and description
- Sidewalk and curb information
- All dimensions
- Manhole invert and rim elevations
- Original and proposed ground line
- Control line with stations
- Easement and/or right-of-way information to include the recorded book and page numbers, or any other data which could conflict with or require deviations in the design of the water main.

Any revisions, amendments or additions made to the original submitted information once the water design is initiated, shall be applied to the original submitted information by the applicant's Engineer and signed by same.

- 2.07 Conflicts Between Plans and Specifications. When a conflict occurs between or within standards, specifications and drawings, an interpretation shall be made by the General Manager, pursuant to Section 1.05 of these Specifications.
- a. Addenda and modifications to the drawings and specifications take precedence over the original documents.
 - b. Should there be a conflict within the Specifications or on the drawings, the General Manager shall decide which stipulation will provide the best installation and his/her decision shall be final.
 - c. In the drawings, calculated dimensions shall take precedence over scaled dimensions and noted material over graphic indication.
- 2.08 Construction Procedure. Following final approval of the plan(s), the applicant may proceed with construction. In addition to all construction requirements contained in other portions of these Specifications, the applicant and his/her Contractor shall observe the following:
- a. Construction shall commence within six months of the approval date shown on the plans or the plans must be resubmitted for review and approval. If construction on the main installation is halted for more than six months, plans must be resubmitted for review and approval.
 - b. The applicant shall secure and pay for all licenses and permits required for the system extension.
 - c. All materials needed to complete the work shall be on hand so that the project may proceed without delay.
 - d. Adequate provisions for notification of customers who may suffer outages must be developed. Outages shall be kept to a minimum in compliance with Section 5.24.d of these specifications.
 - e. Mains shall not be installed unless they can be extended from an approved permanent water source which can supply sufficient water for chlorinating and flushing.
 - f. Mains shall be chlorinated in accordance with Section 5.26 of these specifications.
 - g. The contractor shall be responsible for arranging for or making all taps for main extensions on both public and private water mains. Mains shall only be tapped for service lines after having been installed, chlorinated, tested and flushed to the satisfaction of the Inspector. No tapping of dry mains shall be allowed. See Section 5.24.b of these Specifications.

- 2.09 Surveying. Line and grade for all water mains and appurtenances shall be established by a Professional Engineer or by a Land Surveyor, licensed to practice in the State of Colorado or his/her authorized representative. All work shall be done in a professional manner. Correct alignment and grade of the water mains shall be the responsibility of the owner or developer's Engineer. Approval of the staked alignment and elevations by the Inspector does not relieve the Engineer in any manner from the responsibility for field errors. Sufficient line shall be staked to ensure continual work progress. Under no circumstances shall pipe be installed without line and grade stakes set by the Engineer or Surveyor and approved by the Inspector.

Exception - If a main less than 12-inch diameter is to be extended in an existing street and if the Engineer who prepared the plans can provide evidence that the finish grade of the street is to remain unchanged, no grade stakes need be set. The main shall be installed with a minimum of 5 feet and a maximum of 6 feet of cover.

- 2.10 Placing Survey Lines. Hubs and stakes shall be set on an offset line to mark the location of the center line of the water main. Center line hubs and stakes may be used in addition to the offset hubs and stakes; however, they may not be set in place of the offset hubs and stakes. Normal practice is to set offset hubs and stakes 5 feet to 10 feet off the center line of the water main.

Survey points shall be set a maximum distance of 50 feet apart. All valves, crosses, tees, horizontal and vertical bends and hydrants shall be staked for location and grade. Points of curvature and points of tangency of curves, as well as points on the curve, shall be staked. All stakes shall be flagged to increase their visibility.

Fire hydrants shall be set so that the elevation of the center of the traffic flange is 4 inches above the finish grade of the ground or top of the curb and/or sidewalk. See Section 5.17 and Standard Drawings No. 4 and 5.

- 2.11 Notice of Field Staking and Construction by the Developer. Notice of and preparation for staking for line and grade for water mains shall be provided by the Developer.

It shall be the Developer's responsibility to notify the District a minimum of five (5) working days prior to his/her intent to begin construction. It shall also be the Developer's responsibility to see that the area of construction is free of debris, material, equipment or any other obstacles which may obstruct the placement of stakes or access to reference points.

- 2.12 Inspection.

- a. New installation or replacement of any existing facilities in the water distribution system shall be inspected and approved by a District Inspector.

The Inspector shall ensure that the provisions of the Standard Specifications are carefully complied with especially with regard to the quality of workmanship and materials. Problems which may require sound field judgment, in lieu of strict interpretation of the Standard Specifications, shall be resolved by the Contractor to the satisfaction of the Inspector.

All work shall be performed in accordance with accepted workmanship practices and these Standard Specifications. Any work not accepted by the Inspector shall be redone until compliance with these Standard Specifications is achieved.

All appropriate permits and approved water plans shall be kept on the job site and shall be checked by the Inspector before starting construction.

The Inspector shall not supervise nor set out work or give line and grade stakes. A responsible representative for the Contractor, designated by the Contractor, shall be at the project site at all times that construction is in progress. The Inspector shall discuss the work with the Representative or his/her Supervisors only. Any directions given to the workmen will be given them by the Representative. If at any time during construction it is found that no Representative for the Contractor is at the project site, then such a situation shall be cause for the Inspector to stop work until a Representative is present at the project.

- b. All materials used shall be subject to the inspection and approval of the Inspector at all times. The Inspector has the right to perform any testing deemed necessary to insure compliance of the material with these Specifications. No material shall be used before being inspected and approved by the Inspector. Failure or neglect on the part of the Inspector to condemn or reject inferior materials, or work, shall not be construed to imply their acceptance should their inferiority become evident at any time prior to completion of a one year warranty period. See Section 2.13 of these Specifications. Materials rejected by the Inspector shall be immediately removed from the job site.

After receipt of approved plans from the District, the Contractor shall give at least 48 hours notice to the General Manager prior to starting construction. No construction shall commence sooner than 48 hours after receipt of approved plans.

- c. The District standard working hours are 8:00 AM to 5:00 PM Monday through Friday. Inspections or other direct involvement by District personnel outside of these normal working hours shall be scheduled with the District office during normal working hours. It is requested that at least 12 hours notice be given should any direct involvement by District personnel be required outside of normal working hours. There may be a charge by the District to the contractor for direct involvement by District personnel outside of normal working hours.

- 2.13 Performance Agreement and Bill of Sale. The Developer shall furnish to the District a guarantee for the satisfactory repair or replacement where required, or the cost thereof, of all work, material, services and equipment which becomes defective as a result of faulty materials, faulty installation, or improper handling of material and equipment installed by the Contractor. Such guarantee shall be for a period of one (1) year from the date of acceptance of all work performed. This date shall be the approval date as recorded on the Performance Agreement and Bill of Sale form.

The Performance Agreement and Bill of Sale form shall be provided to the Developer by the District. The Developer shall complete the form and return it to the District for final approval.

A copy of the final approved form will be sent to the Developer.

- 2.14 Special Conditions. When applying for a main extension, special conditions that involve another agency, such as crossing a railroad or highway, may exist. All conditions of the other agency must be satisfied. All designs, drawings and calculations submitted to another agency shall also be submitted in duplicate to the District for approval. Should a conflict in the plans and specifications occur between the District and the other agency, the more stringent plans and specifications yielding a higher quality product shall prevail.

WATER SYSTEM STANDARD SPECIFICATIONS

Chapter 3 - Distribution System Design and Layout

3.01 General. The purpose of this chapter is to provide information for the design and layout of a water distribution system acceptable to the District.

3.02 Quality of the Distribution System. The purpose of these Standard Specifications is to ensure that only proven high quality materials are installed using first class workmanship. Determination of the best materials and constructions methods are based upon lowest life cycle costs, not upon lower initial costs. Sizing and layout of the system are parts of the total consideration of design, operation and maintenance of a water supply system that yields optimum quality service at the lowest total cost to the customer.

3.03 Sizing of Distribution Mains. All mains shall be sized large enough to provide for domestic, irrigation, and fire protection flows to the area requesting service and shall meet the following requirements:

The District reserves the right to size mains to provide service for projected future needs. See Section 2.03 of these Specifications.

In business and industrial areas main sizes may be increased in adherence to the recommendations of the Insurance Services Organization to provide adequate fire flows.

Planned Building Groups may be treated the same as Industrial and Business areas because of the high fire risk. These areas generally require "Private Mains." See Sections 2.01 and 2.04 of these Specifications.

3.04 Fire Protection.

a. Fire Hydrants. The number and location of fire hydrants in a given area is determined by the District. Normal practice is to install fire hydrants on the corners of street intersections. If fire hydrants are to be installed at locations other than street intersections, they shall be located on lines which are established by extending property lot sidelines into the streets. Any other proposed location must be approved by the District. See Standard Drawing No. 4.

Fire hydrant branch lines shall be set at right angles to street mains. The hydrant shall be set at the end of the branch line and shall face the branch line. No horizontal or vertical bends or offsets shall be used in installing fire hydrant branch lines unless approved by the District. Under no circumstances shall any size or manner of tap be made on a fire hydrant branch line between the hydrant and hydrant valve.

In general, fire hydrants shall be placed a maximum distance of 500 feet apart.

- b. Private Mains. When required in business, industrial and building group areas where increased fire protection is necessary, private fire mains and hydrants may be needed. Location of these facilities to be determined and approved by the District.

Private mains shall be treated as large service lines and will require valves to be installed at the connection point to the "District Main" and at the property line. Domestic service, irrigation and/or fire sprinkler lines may be extended to the buildings and area providing all service line and meter installation requirements are complied with.

All private main extensions shall be limited to single platted lots. Extensions will not be allowed to cross lot lines for the purpose of serving two or more platted lots and building complexes. Responsibility for a private main must remain with one property and one ownership. See Sections 2.01 and 2.04 of these Specifications.

Private main extensions, to include fire hydrants, shall be installed in accordance with these Specifications and shall be inspected by the District. See Section 2.12 of these Specifications.

- 3.05 Distribution Regulation Installations. Regulating installations are required to control pressure, provide pressure relief and separate pump and gravity zones throughout the water distribution system. When main extension plans are submitted for review, the need for regulating installations will be determined by the District, based on existing and proposed pressure zones, booster pump areas and the existing distribution system piping. Presently, regulating installations shall be categorized as follows:

- Pressure Regulating Station
- Pressure Relief Station
- Check Valve Station

All regulation installations will be designed by the Applicant and installed by the Owner/Developer subject to District review and approval.

- a. All required piping, regulators, fittings, valves, etc., to be installed within the confines of a station shall be furnished by the Owner/Developer. Upon completion and acceptance of the station, the station shall become the property of the District.
- b. All required concrete pits, concrete, reinforcing steel, manhole assemblies, and the total installation shall be provided by the Owner/Developer in accordance with Standard Drawings No. 24 through 28. Any proposed deviations or changes from these drawings will require engineering plans and specifications, to be provided by the Owner/Developer, and approved by the District. See Section 5.20 of these Specifications.
- c. Responsibility and requirements for installation of regulating stations to be incorporated with pipelines of 12-inch diameter and larger will be specified on the plan and profile drawings.

- 3.06 Pumping Facilities. Booster pumping facilities may be allowed on mains supplying water from the District Distribution System only where specifically authorized by the District. The District will prohibit the installation of pumping facilities where, in its opinion, such installations would be injurious to the operation, or future operation, of the District's system.

All proposed booster pumping facilities shall be considered as a special feature and will be dealt with on an individual case basis. This may include pressure testing of the total installation when determined necessary by the District.

- 3.07 Storage Facilities. Water storage reservoirs are required throughout the distribution system to maintain adequate supply during peak demand periods. Storage reservoirs may also be required adjacent to and on the suction side of pumping facilities. The size, location and type of storage reservoirs shall be determined by the District.

All proposed storage facilities shall be considered a special feature and will be dealt with on an individual case basis.

- 3.08 Layout of the Distribution System.

Width Requirements for District Installations. All District mains shall be installed in dedicated public streets of 50 feet minimum width. When the District determines it is not possible or feasible for an installation to be made in a dedicated street, the installation shall be made in a right-of-way or easement. The conditions under which such an exception will be allowed will be determined for each individual case, and only rights-of-way and easements which conform to the requirements of the District will be accepted. The minimum width right-of-way or easement which will be accepted by the District is a twenty foot (20') exclusive or a forty foot (40') non-exclusive right-of-way or easement. If at the determination of the District, it is not feasible to meet the above requirements, installations may be made in streets, alleys, rights-of-way or easements of other widths when authorized by the General Manager.

Dedicated Streets. Pipe alignment shall be parallel to property lines. Normal practice is to lay the pipe on the south side or the west side of the street, 10 feet from the center line of the street. In any case, pipe alignment shall always be within an established roadway, between the limits of the curb and gutter. Minimum clearance for the edge of the gutter pan shall be 4 feet in all cases. See Standard Drawing No. 1.

Fire Hydrants. All fire hydrants will be installed within dedicated streets or in the rights-of-way or easements as herein above defined. See Standard Drawing No. 4 and No. 5.

Fire hydrants shall be installed only at location designated by the District.

- 3.09 Line Valves. Line valves are required approximately every 400 feet in the distribution system. Where blocks exceed 400 feet in length, one or more line valves may be required between intersections. Street intersections carrying heavy traffic, or containing major water distribution mains in both directions may require as many as four (4) valves, one in each direction. All tee intersections of distribution mains, with the exception of hydrant tees, will require a minimum of two (2) line valves. Where necessary, the Inspector shall require the installation of additional line valves in order to avoid exposing existing customers to high chlorine residual during disinfection of pipelines. See Standard Drawing No. 7.
- 3.10 Connections to Mains for Fire Sprinkler Lines. Sprinkler heads found in hotels, motels, public assembly places, warehouses, etc. are supplied by a fire line. The fire line shall be sized by the persons responsible for the structure it protects. The District will not size fire lines.
- 3.11 Clearance and Encasement Design for Sanitary and Storm Sewer Crossings. Normal design and construction practice shall provide for at least 18 inches separation between the crown of a sewer pipe and the bottom of the water main where the water main is laid over or above a building sewer (service line), sanitary sewer or storm sewer.

Where a sewer (building sewer, sanitary sewer or storm sewer) passes over or is less than 18 inches under a water main, one of the following design and construction procedures shall be followed:

- a. One length of pipe at least 18 feet long shall be constructed in the sewer and centered over or under the water main. Joints between the sewer pipe and the special pipe should be encased in a concrete collar at least 6 inches thick and extending at least 6 inches either side of the joint. This shall be in addition to the use of a premanufactured adapter coupling such as a Mission, Fernco or Caulder coupling with stainless steel tightening bands.
- b. Reinforced concrete encasement shall be installed around the sewer pipe. The encasement shall be in accordance with Standard Drawing Nos. 18, 19 and 20. In general, the encasement shall be a minimum of 12 inches thick and extend a distance of 10 feet either side of the center of the water main. Where the water main passes beneath a storm sewer pipe or an open drainage channel, the water main shall be encased in reinforced concrete in accordance with Standard Drawing Nos. 18 or 19.
- c. Comply with current Colorado Department of Public Health and Environment (CDPHE) requirements.

Where water mains pass under sewers (building sewer, sanitary sewer or storm sewer), in addition to one of the two items above, the following shall be accomplished to provide protection:

- a. A vertical separation of at least 18 inches between the invert of the sewer and the top or crown of the water main.
- b. Adequate structural support for the sewer pipe to prevent excessive deflection of joints and settling on and breaking the water main. Such structural support shall be in accordance with Standard Drawing No. 20 or approved modifications thereto.
- c. Comply with current Colorado Department of Public Health and Environment (CDPHE) requirements.

As previously stated in these Specifications, parallel installations of water mains with sanitary sewer, storm sewer or sewer manholes shall provide for a 10 foot horizontal separation, edge of pipe to edge of pipe. Where special conditions exist which prohibit a horizontal separation of 10 feet, a water main may be laid closer to a storm or sanitary sewer provided that:

- a. It is constructed in a separate trench with undisturbed soil material between the water main and the sewer main.
- b. The elevation of the crown of the sewer is at least 18 inches below the bottom of the water main pipe. Such separation shall be undisturbed or compacted soil material.
- c. Where a minimum of 18-inch vertical separation cannot be obtained, the sewer shall be constructed of materials and with joints that are equivalent to water main standards of construction.
- d. Comply with current Colorado Department of Public Health and Environment (CDPHE) requirements.

WATER SYSTEM STANDARD SPECIFICATIONS

Chapter 4 - Materials

- 4.01 Materials and Testing. Detailed technical specifications for purchase or approval of materials are included in this chapter. All materials shall conform to this Specification and to all limitations on acceptable makes and styles.

All materials furnished shall be new and undamaged. Everything necessary to complete all installations in accordance with the Standards of the District shall be furnished and installed whether shown on approved drawings or not; and all installations shall be completed as fully operable, functioning parts of the District's system.

Acceptance of materials, or the waiving of inspection thereof, shall in no way relieve the applicant of the responsibility for furnishing materials meeting the requirements of the Specifications.

New water industry products or materials will be tested, if it is the opinion of the District that the product or material has some merit. The District will establish the criteria for testing or evaluating the product. The District reserves the right to accept or reject any product or material regardless of the test results.

- 4.02 Size of Mains. The size of mains shall be in accordance with Section 3.03 of these Specifications.

- 4.03 Distribution System Piping. The District has established minimum design safety factors and materials for system piping. The following minimum AWWA pressure classes for acceptable types of pipe are required:

- | | |
|---------------------------------|--|
| a. Pipe Pressure Classes/Rating | |
| Ductile Iron Pipe (DIP) | Class 350, all system pressures |
| Polyvinyl Chloride Pipe (PVC) | AWWA C900, DR14 greater than 130 psi, less than 175 psi static pressure;
AWWA C900, DR 18 less than 130 psi static pressure |

b. Ductile Iron Pipe

1. General. All ductile iron pipe shall be manufactured in accordance with AWWA Standard C151 and ANSI A21.51 "Ductile-Iron Pipe, Centrifugally Cast in Metal Molds or Sand-Lined Molds, for Water or Other Liquids," with the following additional requirements or exceptions.
2. Size of Pipe. This specification shall cover ductile iron pipe in 4-inch, 6-inch, 8-inch, 10-inch, 12-inch, 16-inch and 20-inch nominal diameters.
3. Joint Type. "Push-on single gasket" type conforming with applicable requirements of AWWA Standard C111 and ANSI A21.11, "Rubber-Gasket Joints for Ductile-Iron and Cast-Iron Pressure Pipe and Fittings."
4. Class and Type. Pipe furnished under this specification shall conform to the following thickness classes as a minimum:

4" - 20" Diameter: Class 350
5. Pipe Length. Pipe furnished under this specification shall have normal laying lengths of either 18 feet or 20 feet. Random lengths are not acceptable.
6. Material Strength. Iron used in the manufacture of pipe furnished under this specification shall have 60/42/10 physicals.
7. Cement Mortar Lining. Pipe furnished under this specification shall have standard thickness cement mortar linings in accordance with AWWA Standard C104 and ANSI A21.4, "Cement-Mortar Lining For Ductile-Iron Pipe and Fittings for Water."

c. Polyvinyl Chloride Pipe

1. General. All polyvinyl pipe shall be manufactured in accordance with AWWA Standard C900, "Polyvinyl Chloride (PVC) Pressure Pipe, 4-Inch Through 12-Inch, For Water," with the following additional requirements or exceptions.
2. Size of Pipe. This specification shall cover polyvinyl chloride pipe in 4-inch, 6-inch, 8-inch, 10-inch and 12-inch nominal diameters with ductile iron equivalent outside diameters.
3. Joint Type. Pipe joints shall be made using an integral bell with an elastomeric gasket push-on type joint.
4. Pipe Length. Each length of pipe will be a standard laying length of 20 feet. Random lengths shall not be acceptable.

5. Manufacturer. The only PVC pipe approved for installation within the District's water distribution system shall be:

- (a) J-M Pipe "Blue Brute" PVC water pipe, DR-18 and DR-14, meeting specifications ASTM D2241, AWWA C-900, NSF approved Class 12454 A, ASTM Resin Specification D-1784.
- (b) North Star "AquaLite" C-900 PVC water pipe, DR-18 and DR-14, meeting specifications ASTM D2241, AWWA C-900, NSF approved Class 12454 B, ASTM Resin Specification D-1784.
- (c) CertainTeed "Vinyl Iron Pipe" PVC municipal water pipe, AWWA C-900, DR-18 and DR-14, meeting specifications ASTM D2241, NSF approved Class 12454 B, ASTM Resin Specification D-1784.

4.04 Pipe Fittings. All ductile iron fittings used in the District's water distribution system shall meet the latest AWWA Standard C110 and ANSI A21.10 or AWWA Standard C153 and ANSI A21.53.

All fittings shall be furnished with mechanical joint ends and shall conform to the following:

- a. General. All ductile iron fittings shall be manufactured in accordance with the following AWWA Standards: C104, "Cement-Mortar Lining for Ductile-Iron Pipe and Fittings for Water"; C110, "Ductile Iron and Gray Iron Fittings, 3-Inch Through 48-Inch for Water and Other Liquids"; C111, "Rubber-Gasket Joints for Ductile-Iron and Cast-Iron Pressure Pipe and Fittings"; C153, "Ductile-Iron Compact Fittings, 3 In. Through 16 In., for Water and Other Liquids"; with the following additional requirements or exceptions.
- b. Cement Mortar Lining. All sizes of ductile iron fittings shall be furnished with a cement-mortar lining of standard thickness as defined in referenced specifications and given a seal coat of bituminous material.
- c. Type of Joint. All fittings shall be furnished with mechanical joint ends conforming to referenced specifications.
- d. Thickness Class. All fittings shall be 350 psi pressure rating and shall conform to the dimensions and weights shown in the tables of referenced specifications.
- e. Material. All fittings shall be made from ductile iron.

4.05 Steel Pipe and Fittings. Steel pipe and fittings, when required, shall conform to the following:

- a. General. All steel pipe, fittings and specials shall be fabricated in accordance with AWWA Standard C200, "Steel Water Pipe 6-Inches and Larger," AWWA M-11 Steel Pipe Manual and the requirements on the drawings.

Complete shop drawings shall be submitted to the District for approval prior to any fabrication.

- b. Material. All material used shall be acceptable under the "Standard Specification for Low and Intermediate Tensile Strength Carbon Steel Plates of Structural Quality," ASTM Designation A283, Grade C or D.

Steel pipe, fittings, and specials shall be fabricated to the sizes, dimensions, and shapes as indicated on the drawings. Specified pipe shall be the nominal outside diameter of the pipe. All pipe shall have a wall thickness of at least 1/4 inch.

All flanges shall be forged steel slip-on hub type fabricated in accordance with AWWA Standard C207, minimum Class E.

All fittings shall be fabricated from tested pipe and dye checked in accordance with AWWA Standard C208.

Built-up ends and harness lugs shall be a part of the fabrication as indicated on the drawings.

- c. Protective Coating. All steel pipe, fittings, and specials shall be prepared, primed, lined, coated, painted or wrapped as hereinafter specified.
- (1) Exterior Surfaces in Interior Locations. Exterior surfaces of all pipe, fittings, specials, flanges and accessories exposed in interior locations shall be thoroughly cleaned by sandblasting and given a prime coat of primer in accordance with AWWA Standard C203.
 - (2) Exterior Surfaces Underground. Exterior surfaces of all pipe, fittings, and specials which are to be installed underground shall be cleaned by sandblasting, primed and coated with tape coating systems in accordance with AWWA Standard C214. Coating shall be held back 12 inches from ends to be mechanically coupled. Such uncoated areas shall be primed and coated during construction in accordance with the requirements of AWWA Standard C209.
 - (3) Interior Surfaces. The interior of all steel pipe fittings and specials shall be cleaned and then lined with cement mortar in accordance with AWWA C205, or lined with liquid epoxy according to AWWA Standard C210.

4.06 Gate Valves. Gate valves shall be the same size as the main. Valves shall open to the left (counterclockwise). Gate valves shall conform to the following:

- a. General. All valves shall be manufactured in accordance with AWWA Standard C509 with the following additional requirements or exceptions.
- b. Valve Description. Valves shall be resilient wedge, ductile iron body, fully bronze-mounted, with non-rising stem, resilient seat and epoxy lined.
- c. Service. All valves shall be suitable for frequent operation as well as service involving long periods of inactivity. The operating pressure for all sizes shall be 200 psi with testing pressure of 400 psi.

- d. Valve Stems. Valve stems shall be threaded so that the valve can be opened by turning to the left (counterclockwise). The stem shall be non-rising and be sealed with "O" ring packing. All valves shall be equipped with a 2-inch square wrench nut.
- e. Extension Stems. Provide wherever operating nuts are 5 feet or more below grade. The stems shall consist of solid steel shafting with O.D. not less than O.D. of valve stem or galvanized steel pipe with I.D. not less than O.D. of valve stem. Connect to valve by flexible socket coupling bolted through the extension and operating nut on the valve.
- f. Types of End Connections. All valves shall have a mechanical joint end with gasket, gland and fasteners conforming to the ANSI A21.11 (AWWA Standard C111, "Rubber-Gasket Joints for Ductile-Iron and Cast-Iron Pressure Pipe and Fittings"). Plain rubber gaskets shall be used except that in certain conditions, the District may require the use of special rubber gaskets.
- g. Manufacturer. Because of the problems associated with stocking repair parts for all makes of valves, only the following makes are acceptable for use in the District's distribution system:

American AVK

4.07 Valve Boxes. All buried valves shall be provided with a 6-inch cast iron valve box, slip type. The valve box shall be of a design which will not transmit shock or stress to the valve and shall have enough extension capability to be raised to final street grade. Valve boxes shall conform to the following:

a. General. The manufacturer of valve box components shall be experienced in their design and construction, shall be regularly engaged in their manufacture and shall have produced valve boxes which have given successful service for a period of at least five (5) years.

b. Materials. Valve box parts shall be made of gray cast iron.

Use of an aluminum alloy as a casting material is not acceptable.

c. Approved Patterns. Valve boxes shall be the three-piece adjustable slip type and only the following pattern acceptable:

Tyler Slip Type 6-Inch Cast Iron Valve Box Assembly Series 6855 or equal.

d. Coating. Box, cover and base coated by dipping in asphalt varnish.

e. Cover. Deep socket type with the word "WATER" cast in top for water applications.

4.08 Fire Hydrants. Within the District's distribution system where maintenance, repair, replacement, and parts stocking is the responsibility of the District, only one (1) hydrant as listed is acceptable.

a. General. All fire hydrants shall be designed and manufactured in strict compliance with AWWA Standard C502, "AWWA Standard for Dry-Barrel Fire Hydrants." All references made in this specification are to the above standard unless otherwise noted.

b. Acceptable Brand and Service Limitations:

American AVK Series 27 Series 2780: Nostalgic Style Dry Barrel Hydrant
Static Pressure Less than 200 PSI

c. Size of Hydrant. Hydrants shall have a main valve opening size of 5-1/4 inches and shall be ordered for a 6-foot 6-inch bury unless otherwise approved by the District or designated otherwise on the drawings.

Hydrant bury will be measured from the bottom of the hydrant lateral pipe to finish grade line. Hydrant bury shall be adjusted to provide the minimum required cover on all portions of the hydrant lateral piping.

d. Type of Hydrant. All hydrants shall be the traffic model type. Hydrants shall be the three-way type with one (1) pumper nozzle and two (2) hose nozzles all located on the same horizontal plane.

e. Inlet Connection. Hydrant base shall be provided with a mechanical joint inlet to accommodate 6-inch diameter ductile iron pipe, all in accordance with ANSI A21.11 (AWWA Standard C111, "Rubber Gasket Joints for Ductile-Iron and Cast-Iron Pressure Pipe and Fittings"). Incorporated into the base shall be two (2) lugs for rodding or strapping of pipe.

f. Main valve Assembly. The main valve of the hydrant shall be 5-1/4-inch diameter compression type which closes with the water pressure.

Gasket for valve shall be a replaceable type fabricated of a resilient material, with a threaded bottom plate or nut, complete with seal to prevent leakage of the hydrant shaft.

The valve assembly shall include one or more drain valves which will work automatically with the main valve and drain the barrel when the main valve is in the closed position.

All parts of the main valve assembly shall be so designed that removal of the assembly from the barrel is accomplished without excavation in accordance with Part III of these specifications.

- g. Operating Shaft Nut. The operating nut shall have a pentagon cross section. See Standard Drawing No. 6. Bushings in the bonnet shall be so constructed that it will prevent the operating nut from traveling during opening or closing operation; the bushing shall house a gasket or seal to prevent moisture or foreign material from entering the lubricant reservoir.

The hydrant shall open by turning the operating nut to the left in a counter-clockwise direction and shall have an arrow on top of the bonnet to designate the direction of opening.

- h. Pumper Nozzle and Cap. The pumper nozzle shall be 4-1/2 inch nominal diameter with four threads per inch (National Standard). Threads shall be right-hand. See Standard Drawing No. 6.

Nozzle cap shall be furnished with a synthetic rubber gasket installed in a retaining groove and the dimensions and shape of the nozzle cap nut shall be the same as the operating shaft nut.

Nozzle caps shall be furnished with security chains with one end of each securely attached to the upper barrel section of the hydrant.

All nozzle caps shall be removed by turning counterclockwise.

- i. Hose Nozzles and Caps. The two hose nozzles shall be 2-1/2 inch nominal diameter with seven and one-half threads per inch (National Standard). Threads shall be right-hand. See Standard Drawing No. 6. Each hose nozzle shall include a nozzle cap with nut, security chain and shall be removed by turning counterclockwise.
- j. Color. The upper exposed section of the hydrant above ground shall be painted Rustoleum 1210 - Fire Hydrant Red or equal. The buried portion of the hydrant shall be given a bituminous coating in accordance with Section 681 of AWWA Standard C106.

- 4.09 Corrosion Protection Systems. The testing of the corrosiveness of the soil which a water main passes through may be required by the District. If so required, the testing shall be accomplished by the Applicant. The need for protection will be determined by the District based on the information submitted by the Applicant and/or other information available to the District.

- a. Polyethylene Encasement Material. If determined by the District as a requirement, the pipe, fittings, rods, and appurtenances shall be wrapped in polyethylene in accordance with Section 5.26 and Sheet 9 of the Standard Drawings. Polyethylene Material shall conform to the following:

- (1) General. A polyethylene encasement material shall be manufactured in accordance with AWWA Standard C105, "Polyethylene Encasement for Gray and Ductile Cast-iron Piping For Water And Other Liquids," with the following additional requirements or exceptions.
- (2) Materials. The raw material used to manufacture polyethylene film shall be Type 1, Class A, Grade E-1, in accordance with A.S.T.M. Standard Designation D-1248.

Tensile Strength	1200 PSI minimum
Elongation	300% minimum
Dielectric Strength	800 V/Mil Thickness minimum
Thickness	0.008" (8 mils) minimum Nominal with minus tolerance not exceeding 10% of nominal
Melt Index	0.4 maximum

4.10 Concrete Thrust Blocks, Anchors and Structures. Concrete thrust blocks and anchors shall be sized for the internal pipe pressure and soil bearing capacity. Standard sizes and shapes of thrust blocks and anchors are shown on Sheets 13, 14 and 18 of the Standard Drawings.

Thrust reaction blocking shall be concrete of a mix not leaner than 1-part cement to 2-1/2 parts sand and 5 parts stone, and having a compressive strength of not less than 3000 psi after 28 days. See Section 5.20 of these Specifications. The concrete and any required reinforcement shall meet the following criteria:

a. Materials:

Cement. All cement used shall be Portland Cement acceptable under the "Standard Specifications and Tests for Portland Cement," ASTM Designation C150 of the American Society for Testing and Materials. Cement used shall be Type II.

Aggregates. All the fine and coarse aggregates shall meet soundness requirements, deleterious substance limits and grading limits as set forth in the latest edition of "Standard Specifications for Concrete Aggregates" ASTM Designation C33. The limits for deleterious substances and physical property requirements of the course aggregates shall be selected for the applicable class designation from those listed under severe weathering regions, Table 3, ASTM Designation C33. The maximum size aggregate that is practical for the structure design and placing conditions shall be used in the concrete.

Water. The water used in all concrete shall be free from objectionable quantities of silt, organic matter, alkali, salts, and other impurities.

Admixtures. An air-entraining agent shall be used in all concrete. The agent used shall conform to "Standard Specification for Air-Entraining Admixtures for Concrete," ASTM Designation C260. The amount of air-entraining agent used shall be such as will affect the entrainment of $5\% \pm 1\%$ of volume of the concrete.

A water-reducing admixture (WRA) may be used unless otherwise noted by the District. The admixture shall conform to ASTM Designation C494 for Type A or Type D chemical admixture, shall contain no calcium chloride, and shall be compatible with the cement being used.

The Contractor shall be responsible for any difficulties arising or damages occurring as a result of the selection and use of any admixture such as a delay or difficulty in concrete placing or damage to concrete during form removal.

- b. Concrete Quality. All Concrete shall have a minimum 28-day compressive strength of 3,000 psi and a maximum slump of 4 inches.
- c. Testing. When determined necessary by the District, field control tests consisting of aggregate gradation tests, slump tests, air content tests, and making compression test cylinders, shall be performed by qualified personnel in the presence of the Inspector.
- d. Concrete Reinforcement. Reinforcements shall be accurately formed and shall be free from loose rust, scale and contaminants which reduce bond. Unless otherwise shown on the drawings or specified herein, all requirements shall conform to the latest ACI Standard 318 and the Uniform Building Codes.

Reinforcements shall be accurately positioned on supports, spacers, hangers, or other reinforcements and shall be secured in place with wire ties or suitable clips.

- e. Reinforcement Material. All deformed reinforcing bars shall conform to ASTM Standard A615, Grade 60.

4.11 Mechanical Joint Restraint. Mechanical joint pipe restraints may be used for restraining and/or connecting fittings, valves and hydrants to reduce the installation of concrete reverse anchors, thrust reaction blocks and/or steel tie rods; however, anchors, thrust blocks and/or tie rods will still be required where indicated on plans and standard drawings.

- a. When mechanical joint pipe restraints are installed on ductile iron pipe, the length of pipe to be restrained shall be determined in accordance with the "Ductile Iron Pipe Research Association" (DIPRA) Recommendations, "Thrust Restraint Design for Ductile Iron Pipe." See Standard Drawings Nos. 27 and 28.

Ductile iron pipe shall be restrained with Series 1100 mechanical joint ductile iron retainer glands manufactured by EBAA Iron Sales, Inc. or an approved equivalent.

- b. Polyvinyl chloride (PVC) pipe may be restrained with the use of mechanical joint restraints subject to approval of the District. Refer to Standard Drawings for typical installation details.

PVC pipe mechanical joint restraints shall be series 2000 PV Megalug Retainer Glands manufactured by EBAA Iron Sales, Inc. or an approved equivalent.

- c. Ultra-compact MJ restraint fittings may be used when connecting and restraining fire hydrants, valves or other MJ fittings directly to the tee with bolt-through connection. Design basis is based upon INFAC T CORPORATION Foster Adaptor, Flex T-2 and Flex T-3 fittings.

4.12 Casing Pipe. Installation of mains through rights-of-way or easements of others, such as highways, railroads, etc., may require casing pipes for bores. The type of casing material and its properties will be specified by the agency granting permission to cross. Such crossing shall be subject to approval by the District to avoid conflicts in requirements or standards between the District and the persons or agency granting permission to cross. See Section 5.24 of these Specifications.

4.13 Responsibility for Materials.

- a. Material Furnished by Contractor. The Contractor shall be responsible for all material furnished by him/her and shall replace at his/her own expense all such material found defective or damaged in handling after delivery by the manufacturer. This shall include the furnishing of all material and labor required for the replacement of installed material discovered defective prior to final acceptance of the work and materials found defective during the warranty period.
- b. Responsibility for Safe Storage. The Contractor shall be responsible for the safe storage of material furnished by or to him/her and accepted by him/her and intended for the work, until it has been incorporated in the completed project. The interior of all pipe, fittings, and other accessories shall be kept free from dirt and foreign matter at all times. Valves and hydrants shall be drained and stored in a manner that will protect them from damage by freezing.

4.14 Handling of Materials.

- a. Hauling of Materials. All materials furnished by the Contractor or to the Contractor shall be delivered and distributed at the job site by the Contractor.

All pipe, valves, fittings, hydrants and accessories shall be loaded and unloaded by lifting so as to avoid shock or damage. Under no circumstances shall materials be dropped. Pipe shall not be skidded or rolled against pipe already unloaded.

- b. Unloading at the Site of Work. When distributing the material at the site of work, each piece shall be unloaded opposite or near the place where it is to be installed in the trench.
- c. Care of Coatings and Linings. All materials shall be so handled that the coating and lining will not be damaged. If, however, any part of the coating or lining is damaged, the replacement or repair of the damaged material shall be done to the satisfaction of the District. All material handling equipment and material handling methods shall be approved by the District.

4.15 Pressure Regulation Valves and Accessories.

a. Pressure Reducing and Pressure Sustaining Valves.

1. Application: Reduce downstream pressure and sustain a minimum upstream pressure
2. Type: CLA-VAL Model 92-01 series
PRV No. 1 & 2 Hydraulically operated, pilot controlled, diaphragm type with flow clean strainer; open and closing speed controls; pilot system shut-off cocks
3. Body: Cast iron, ASTM A48, globe body
PRV No. 1 & 2
4. Valve trim: Stainless steel
PRV No. 1 & 2
5. Accessories: Pressure gauges on inlet and outlet piping
6. Size:
PRV No. 1 - As shown on approved plans
PRV No. 2 - As shown on approved plans
7. Pressure rating: Class 250
PRV No. 1 & 2
8. Adjustment Ranges: Downstream: As shown on approved plans
Upstream: As shown on approved plans

b. Pressure Gauges.

1. Type: Dial, liquid filled
2. Range: Downstream: 0 to 150 psi
Upstream: 0 to 300 psi
3. Accuracy: 3% full scale range
4. Dial size: 3-1/2" diameter
5. Accessories: Isolation ball valve on nipple; snubbers on nipple
6. Design basis: U.S. Gauge P580L-1000

WATER SYSTEM STANDARD SPECIFICATIONS

Chapter 5 - Pipe Installation

- 5.01 Approval by the District. Throughout these Specifications many handling, and installation procedures, tools, equipment, and materials will require approval by the District. Approval by the District shall in no manner render the District liable for any injuries suffered or equipment damaged. Approval by the District is used solely as a means to insure quality control and safety.

Safety of workers shall be provided as required by the Occupational Safety and Health Act (OSHA). The Contractor is solely responsible for job safety.

- 5.02 Handling of Materials. Pipe and fittings shall be loaded and unloaded by lifting so as to avoid shock or damage. Under no circumstances shall such material be dropped. If, however, any part of the coating or lining is damaged, the replacement or repair of the damaged pipe shall be done to the satisfaction of the District. Any pipe or fittings that are not acceptable to the District shall be removed from the job site immediately. All pipe handling equipment and pipe handling methods shall be approved by the District in conjunction with the methods and equipment recommended by the manufacturer.

- 5.03 Inspection and Preparation of Pipe and Fittings. Before placing pipe in the trench, each pipe or fitting shall be thoroughly cleaned of all foreign material, kept clean at all times thereafter, and carefully examined for cracks and other defects before installation. Bell ends and spigot ends are to be examined with particular care. Defective pipe or fittings shall be laid aside for inspection by the District Inspector who will prescribe corrective repairs or rejection.

All lumps, blisters and excess coating shall be removed from the bell-and-spigot end of each pipe and fitting, and the outside of the spigot and the inside of the bell shall be wire brushed and wiped clean, dry and free from oil and grease before the pipe or fitting is installed. Dirt and any other material must be removed from the barrel of the pipe before installation.

- 5.04 Cutting and Fitting of Pipe. Pipe shall be cut, whenever necessary, to conform to location of fittings, line or grade. All cuts shall be straight and true, and in a workmanlike manner so as to leave a smooth end without damaging the pipe or its cement lining. All burrs shall be removed from the ends of cut pipe, and the end lightly rasped or filed. All tools used in cutting pipe shall be approved by the District. See Standard Drawing No. 17.

- 5.05 Pipe Joint Lubrication. Joint lubricant shall be supplied by the pipe manufacturer and approved by the District. Joint lubricant shall be non-toxic, and water soluble.

- 5.06 Pipe Alignment and Grade. In laying pipe, the intent is to lay to a set line and grade within a tolerance of 3 inches plus or minus. On slopes of zero grade, the intent is to lay to grade. Fittings, valves and hydrants shall be installed at staked locations and elevations; spigots centered in bells; and all valve and hydrant stems plumb.

In new developments, street right-of-way and/or property line and lot corner points must be set and in visible evidence before water installations can proceed. In existing areas sufficient right-of-way, property or easement delineation must be recovered or established before water installation can proceed. Offset stakes for alignment and grade shall be set by the Contractor's, Owner's or Developer's engineer. Any replacement of stakes shall be at the expense of the Contractor, Owner

or Developer.

When laying pipe on curves, the intent is to lay to the staked alignment. The pipe shall be kept in alignment by placing all deflecting joints or bends on the curve. Short lengths shall be used as necessary to accomplish the curvature without exceeding individual deflections specified by the District. See Standard Drawing No. 16. Bends shall be used whenever individual deflections exceed those specified by the District.

For pipes with an internal diameter of 10 inches or less, the depth of fill over the pipe measured from the proposed finish grade over the pipeline to the top of the pipe shall be a minimum of 5 feet and maximum of 6 feet unless otherwise specified. All pipes with an internal diameter of 12 inches or more shall be installed to the depth shown on the required plan and profile drawings.

If difficulties arise when crossing an interference and where specifically approved by the District or its Inspector, deviations from the above minimum and maximum depths of cover may be permitted. See Standard Drawing No. 20.

Any changes in alignment and grade must be authorized by the Inspector and shall be accomplished by the installation of additional fittings. "Breaking" of joints is permitted only when installing pipe on horizontal or vertical curves.

Pipe shall be laid with the bell ends facing in the direction of laying, unless directed otherwise by the District. Where pipe is to be installed on a grade of ten percent (10%) or greater, the laying shall start at the bottom and shall proceed upward with the bell ends of the pipe upgrade.

- 5.07 Deviation from Alignment and Grade Occasioned by Other Structures. Whenever obstructions not shown on the plans interfere to such an extent that alteration in the plans is required, the District shall have the authority to determine the best method of correction. The District may order a deviation from the line and grade of the structures and/or removal, relocation and reconstruction of the obstructions. See Standard Drawing No. 20.
- 5.08 Temporary Bulkheads. Whenever the pipe is left unattended, temporary plugs shall be installed at all openings. Temporary plugs shall be of such design as to prevent water, debris, children and animals from entering the pipe. All temporary plugs shall be provided by the Contractor and approved by the Inspector.
- 5.09 Frost. No pipe or appurtenant structure shall be installed upon a foundation into which frost has penetrated, or at any time when the Inspector deems there is danger of ice formation or frost penetration at the bottom of the excavation. No pipe or appurtenant structure shall be installed unless backfilling can be completed before the formation of ice and frost.
- 5.10 Excavation, Bedding and Backfill. See Part III of these Specifications for all earthwork.
- 5.11 Lowering of Material into the Trench. Proper implements, tools and facilities satisfactory to the District shall be provided and used by the Contractor for the safe and convenient performance of the work. All pipe, fittings, valves and hydrants shall be carefully lowered into the trench piece by piece by means of a derrick, ropes, or other suitable tools or equipment, in such a manner as to prevent damage to water main materials and their protective coatings and linings. Under no circumstances shall water main materials be dropped or dumped into the trench.

If damage occurs to any pipe, fitting, valve, hydrants or water main accessories in handling, the damage shall be immediately brought to the attention of the Inspector. The Inspector shall prescribe corrective repairs or rejection of the damaged items.

- 5.12 Laying of Pipe. Every precaution shall be taken to prevent foreign material from entering the pipe while it is being placed in the line. If the pipe laying crew cannot put the pipe into the trench and in place without getting earth into it, the Inspector may require that before lowering the pipe into the trench, a heavy, tightly woven canvas bag of suitable size shall be placed over each end and left there until the connection is to be made to the adjacent pipe. During laying operations, no debris, tools, clothing or other materials shall be placed in the pipe.

As each length of pipe is placed in the trench, the spigot end shall be centered in the bell and the pipe forced home with a slow steady pressure without jerky or jolting movements and brought to correct line and grade. The pipe shall be secured in place with approved backfill material tamped under it except at the bells. Precautions shall be taken to prevent dirt from entering the joint space. No wooden blocking shall be left at any point under the pipeline.

No pipe shall be laid when, in the opinion of the District, trench conditions are unsuitable.

- 5.13 Ductile Iron Pipe. There is only one nominal dimension of the spigot outside diameter and the bell inside diameter for each size of push-on joint pipe. In some existing older pipelines, some variation in outside spigot diameter may exist. When connecting to an existing line, care should be exercised to ensure that the outside diameter of the existing line is the same as the outside diameter of the push-on joint or mechanical joint pipe being installed, otherwise a special adapter to join the two lines may be necessary.

- a. Push-On Joint. Immediately before joining two lengths of ductile iron pipe, the inside of the bell, and the outside of the spigot end, and the rubber gasket shall be thoroughly cleaned to remove oil, grit, excess coating and other foreign matter. The rubber shall be flexed inward and inserted in the gasket recess of the bell socket. Since different manufactured brands of pipe require different types of gaskets, the Contractor shall exercise caution to ensure that the correct type of gasket is used.

A thin film of approved gasket lubricant shall be applied to either the inside face of the gasket, or the spigot end of the pipe, or both.

The spigot end of the pipe shall be placed in the bell end with care to prevent the joint from contacting the ground. Pipe furnished without a depth mark on the spigot end shall be marked before assembly to assure insertion to full depth of the joint. The pipe shall be kept in straight alignment and the joint shall be completed by pushing the pipe home with a slow, steady pressure without jerky or jolting movements by using a forked tool or jack-type tool or other device approved by the District. If pipe is pushed home with a backhoe bucket, a wooden shield must be placed between the backhoe bucket and the end of the pipe. The spigot end of field cut pipe lengths shall be filed, or ground to resemble the spigot end of such pipe as manufactured.

Upon completion of joining push-on joint pipe, an inspection shall be made to assure that the gasket is correctly aligned in the gasket recess of the bell socket and not twisted or turned.

Whenever it is necessary to deflect push-on joint pipe, the amount of deflection shall not exceed the maximum deflections specified by the District. See Standard Drawing No. 16.

- b. Mechanical Joint Pipe. Before joining mechanical joint cast or ductile iron fittings to ductile iron pipe, the outside of the spigot, the inside of the bell and the rubber gasket shall be thoroughly cleaned to remove oil, grit, excess coating, and other foreign matter.

Normal practice is to lubricate the joint with a soap solution; however, in cold weather the joint may be assembled dry if approved by the Inspector. Extreme care should be exercised in making dry joints.

The cast iron gland shall be slipped on the spigot end of the pipe with the lip extension of the gland toward the socket, or bell end. The rubber gasket shall be placed on the spigot end with the thick edge toward the gland.

The pipe shall be pushed in until the spigot end fully penetrates the bell. The gasket shall then be pressed into place within the bell evenly around the entire joint. The cast iron gland shall be moved along the pipe into position for bolting; the bolts inserted, and the nuts screwed finger tight, then tightened with a torque limiting wrench. Torques for the various sizes of bolts shall be as follows:

<u>Bolt Size</u>	<u>Ft. Lbs.</u>
5/8 inch	45-60
3/4 inch	75-90
1 inch	85-100
1-1/4 inch	105-120

Nuts spaced 180 degrees apart shall be tightened alternately in order to produce equal pressure on all parts of the gland.

Whenever it is necessary to deflect mechanical joint pipe, the amount of deflection shall not exceed the maximum deflections specified by the District. See Standard Drawing No. 16.

5.14 Polyvinyl Chloride Pressure Pipe.

- a. Elastomeric Gasket Joint. Immediately before joining two lengths of PVC pipe, the inside of the bell or coupling, the outside of the spigot and the elastomeric gasket shall be thoroughly cleaned to remove all foreign material.

Lubrication of the joint and rubber gasket shall be done in accordance with the pipe manufacturer's specifications.

Care shall be taken that only the correct elastomeric gasket, compatible with the annular groove of the bell, is used. Insertion of the elastomeric gasket in the annular groove of the bell or coupling must be in accordance with the manufacturer's recommendations. Pipe that is not furnished with a depth mark shall be marked before assembly to assure that the spigot end is inserted to the full depth of the joint.

The spigot and bell or coupling shall be aligned and pushed until the reference line on the spigot is flush with the end of the bell or coupling. Pushing shall be done in a smooth, steady motion. Upon completion of joining the pipe, an inspection shall be made to assure that the gasket is correctly aligned in the gasket recess of the bell socket and not twisted or turned.

Deflection may not be allowed at the joints of some PVC pipe. When these types of pipe are to be installed, bends shall be used where deflection is required.

Installation of PVC pipe will be in accordance with the manufacturer's recommendation. A No. 6 copper wire will be attached to all PVC pipe for the purpose of future location. See Standard Drawing No. 12.

- b. Pipe Storage. Pipe stored outside and exposed to sunlight for more than thirty (30) days shall be covered with an opaque material such as canvas. Clear plastic sheets shall not be used to cover pipe. Air circulation shall be provided under the covering.
- c. Handling of Pipe in Cold Weather. PVC pipe has reduced flexibility and impact resistance as temperatures approach and drop below freezing. Extra care should be used in handling and installing PVC pipe during cold weather.

5.15 Installation of Valves. Valves shall be handled in such a manner as to prevent any injury or damage. All joints shall be thoroughly cleaned before installation.

Valves shall be located at the points on the main as indicated on Standard Drawing No. 7, unless specified otherwise by the District.

Valves shall be set and joined to the pipe in the manner previously specified for cleaning, laying and joining push-on and mechanical joint pipe. Valves shall be set in such a manner that the valve stems are plumb. If necessary, to provide a firm subgrade or surface on which to install a valve, solid precast concrete blocks or a cast-in-place concrete pad may be placed beneath the valve body. If cast-in-place concrete is used, extreme care shall be taken to assure that flange bolts are not constrained by the concrete. No wood blocking will be allowed.

Valves shall be operated prior to installation to ensure good operating condition.

Where necessary, the Inspector shall require the installation of additional valves not shown on the plans. See Section 3.09 of these Specifications.

5.16 Valve Boxes.

- a. Installation. A valve box shall be provided for every valve. The valve box shall not transmit shock or stress to the valve and shall be centered and plumb over the operating nut of the valve, with the box cover set to the required elevation. It will be the responsibility of the Developer to ensure that valve boxes are plumb and raised to the proper elevation.

Paving of any street requires that all existing valve boxes be located and prepared for final raising to the finish street surface as shown on Standard Drawing No. 8.

- b. Inspection. Prior to paving, a final inspection is required and can be arranged by contacting the District. Inspections should be requested twenty-four (24) hours in advance of need.

5.17 Installation of Fittings. All fittings in the District's Water Distribution system shall be mechanical joint in compliance with the material specification. Fittings shall be set and joined in the manner described in Section 5.13.b of these Specifications.

The use of "wyes" in main extensions or private pipe extensions is strictly prohibited except in special installations as directed by the District.

5.18 Fire Hydrants.

- a. Installation. All hydrants shall be staked for location and grade. Final location and grade shall be in accordance with the approved drawings. Offset stakes not further than 12 feet from the fire hydrant are acceptable. All hydrants shall stand plumb and be installed as indicated on Standard Drawing No. 5.

Each hydrant shall be connected to the main by a 6-inch branch line. An independent 6-inch gate valve shall be installed on each fire hydrant branch.

No service line connections shall be installed between the fire hydrant and the fire hydrant control valve.

- b. Anchorage. The bowl of each hydrant shall be well braced against the unexcavated earth at the end of the trench with a concrete thrust block. The bottom of the hydrant bowl and the hydrant valve shall be supported with eighteen by eighteen by four inch (18"x18"x4") pre-cast concrete blocking slabs. The hydrant shall be tied to the hydrant valve and the hydrant valve tied to the tee with anchor pipe or with two, 3/4-inch all thread galvanized rods as shown on Standard Drawing No. 5.

Mechanical joint pipe restraints in conformance with Section 4.11 of these Specifications may be used in lieu of all-thread rods.

Whenever a fire hydrant is installed at the termination point of a main extension (such as in a cul-de-sac), then tie rods and concrete reverse anchors will be required for both the fire hydrant valve (which in this case is also a line valve on the main) and the fire hydrant lateral or branch line connected to the fire hydrant. See Standard Drawing No. 5. Additional concrete anchors or tie rods may be required at the direction of the Inspector.

If bends are needed to bring a hydrant to a desired horizontal or vertical position, special concrete reverse anchors, anchor pipe, mechanical joint pipe restraints or all thread tie back rods, or a combination of all these along with a riser may be required. In any case, a riser no longer than 2 feet will be acceptable, and it will be the Contractor's responsibility to set the safety flange at the proper grade.

- c. Drainage. Whenever a hydrant is set, drainage shall be provided at the base of the hydrant by placing rock from the bottom of the trench, to at least 12 inches above the barrel flange of the hydrant, and to a distance of 12 inches around the elbow. The minimum distance from the bottom of the trench to the bottom of the hydrant elbow shall be 6 inches. The minimum of rock placed shall be 1/3 cubic yard. The rock shall be a well-graded gravel, cobble, or crushed rock, free of dirt.
- d. Hydrant Protection in Corrosive Soils. In areas where soil resistivity requires corrosion protection, all ductile iron branch lines and hydrants shall be protected. All pipe, rods and fittings, from finished ground level on the hydrant barrel up to and including the tee, shall be encased in polyethylene wrap. The type of polyethylene and manner in which it is to be installed shall conform to Section 5.26 of these Specifications. Bedding material shall be as specified in Part III of these Specifications.

- 5.19 Dead Ends and Blow Offs. All dead ends on new mains shall be closed with cast iron plugs or caps; such dead ends shall be equipped with suitable concrete anchors and blow off facilities.

The Contractor shall furnish, install or remove temporary blow offs at locations shown on the drawings or designated by the District. See Standard Drawing No. 22.

The Contractor shall install permanent blow offs where indicated on the drawings. A permanent blow off is defined as one which will be left in place at the completion of all proposed installations. Refer to Standard Drawing No. 22.

5.20 Thrust Blocks and Anchors.

- a. Installation. Thrust blocks and/or anchors shall be constructed at all bends, tees, plugs and fittings which require reaction support due to unbalanced line thrust. Care shall be taken not to block outlets or to cover bolts, nuts, clamps or other fittings or to make them inaccessible. The Standard Drawings Sheets 13 and 18, show size and shape of thrust blocks and anchors. Bearing surface areas are minimum areas to bear against the undisturbed trench wall. If in the opinion of the District, the soil bearing capacity is not sufficient to provide adequate restraint based on minimum bearing areas shown on the Standard Drawings, then the minimum bearing area shall be increased to a size that will ensure adequate restraint. In every instance, the thrust block or anchor shall bear against undisturbed earth. When it is impossible, through over excavation or other cause, to pour a thrust block or anchor against undisturbed earth, harness rods or mechanical joint pipe restraints shall be required to anchor the fittings to the main.

Thrust blocks will be required on large taps regardless of whether a tapping sleeve or tapping saddle is used. Refer to Standard Drawing No. 14 for tap and main size combinations requiring thrust block installation.

All debris, water or ice shall be removed from the place to be occupied by the concrete. Concrete shall not be placed on frozen subgrade. Concrete shall be placed in the presence of the Inspector unless inspection has been waived prior to the placement.

- b. Form Work for Thrust Blocks and Anchors. All forming for concrete thrust blocks and anchors will be done by bulkheading around the shape of the thrust block or anchor with burlap or reinforced paper sacks filled with sand or earth. Sacks shall be of a size easily handled when full, and shall be left in place in the trench. Wood forms may be used in some cases; however, all wood will be removed before backfilling.

No horizontal struts or braces required for trench shoring shall remain in the concrete thrust blocks. Prior to placing concrete, the forms and ditch bank shall be inspected and approved by the Inspector.

- c. Concrete and Curing Time. Thrust blocks shall be concrete of a mix not leaner than 1-part cement to 2-1/2 parts sand and 5 parts stone, and having a compressive strength of not less than 3,000 psi after 28 days.

Minimum curing time for concrete thrust blocks regardless of additives shall be thirty-six (36) hours for anchors containing 2 cubic yards or less, forty-eight (48) hours for anchors containing more than 2 cubic yards but less than 6 cubic yards, and seventy-two (72) hours for anchors containing more than 6 cubic yards but less than 12 cubic yards. Anchors containing more than 12 cubic yards will be cured as directed by the District Inspector. Curing time for anchors having flanged rods or other accessories embedded in them for the purpose of tying pipe and/or fittings directly to the anchor will require approximately twenty-five percent (25%) additional curing time.

No water main will be charged or pressurized without the approval of the Inspector. All thrust blocks and anchors must meet the minimum curing time unless, under certain circumstances, the Inspector may elect to shorten or extend the time of curing.

- d. Compaction of Fill Over Thrust Blocks and Anchors. Backfill may be placed over thrust blocks and anchors once the surface has set sufficiently to resist the weight of the backfill. However, no tamping or compacting shall be allowed above the thrust block or anchor for a minimum of thirty-six (36) hours after placement or as directed by the Inspector.

- 5.21 Vaults. Vaults may be precast or poured-in-place and shall be constructed in accordance with these Standard Specifications. Precast vaults shall be so designed that all joints and corners are waterproof. Precast and poured-in-place vaults shall be made waterproof after construction by use of sealants, epoxies or other approved methods. All dimensions, locations and elevations shall be coordinated by the Developer and Contractor and meet the requirements of the District.

Concrete footers shall be required as indicated on the drawings.

All vaults shall be constructed to meet H.S. 20-44 traffic loading conditions and 300 psf surcharge load.

All manhole rings and covers, ladder rungs, pipe arches, sleeves, etc., shall conform to the drawings. See Standard Drawing No. 34 and 35.

- 5.22 Harness Rods. Harness rods and lugs shall be used at all bends and fittings where thrust blocks cannot be used due to existing field conditions or where harness rods and lugs are specifically required by these Specifications, installation plans, or the Inspector. See Standard Drawing No. 26.

- 5.23 Bridging and Encasement of Pipe. Under certain conditions when the water main is to be installed over or under an existing or proposed utility or structure, the District may require bridging or encasement of the pipe.

If, in the opinion of the District, there exists the possibility of settlement of the pipe being installed over an existing utility or structure, then bridging of the pipe shall become necessary. This condition shall also apply to other underground utilities or structures being installed over existing water mains. The District shall determine the size and location of the concrete bridging. See Standard Drawing No. 21.

Under certain conditions, the District may require the complete encasement of water mains with concrete. The District shall determine the size, length and location of these encasements. See Standard Drawing No. 19.

5.24 Encasement or Sleeve Pipe. Wherever it is necessary to provide an encasement or sleeve for the water main, the water main shall not be inserted into the encasement or sleeve pipe without providing insulating skids for each joint of the water main. Insulating skids shall be of a type such as the "P.S.I. Model A12 Steel Casing Insulators" or equivalent. In addition, no encasement or sleeve pipe shall be installed without protecting the ends of the pipe with adequate open joint masonry which will deter dirt and debris from entering, but at the same time will allow water to escape from the encasement or sleeve pipe. Encasement pipes shall be protected both inside and out with corrosion resistant materials having a bituminous base. Encasement or sleeve pipe, size, length, type and sidewall thickness will be determined by the District. See Section 2.14 of these Specifications.

5.25 Connections to the District's System.

a. Connections. Connections to the District system shall be in a neat and workmanlike manner. An Inspector shall be present at all times during the construction of the connection. The connection is subject to approval by the District. Under no circumstances shall a non-disinfected main, which cannot be isolated, be connected to an existing distribution main in service.

b. Tapping Existing Mains. The Contractor shall be responsible for making or arranging for all taps for main extensions. Permits for service taps shall only be issued to a master plumber unless otherwise approved by the District. The Contractor shall notify the District a minimum of twenty-four (24) hours prior to tapping. Once the tap is complete, the Contractor shall be responsible for protection of the tapping sleeve or saddle and the tapping valve against freezing or other damage. The Contractor shall also be responsible for all backfill, compaction, paving, curb and gutter, etc. See Standard Drawing No. 25.

c. Operation of Valves. In connecting to the District's system, it may be necessary to operate existing valves.

Valves on the District's system that must be operated to make a connection shall be operated by District personnel only. The Contractor shall give the Inspector forty-eight (48) hours' notice to arrange for operating valves. Both the Contractor and the Inspector shall be present when the valves are operated.

d. Interruption of Service. Installation of a connection that will require closing existing valves may cause an interruption of water service to existing District customers. Affected customers must be notified twenty-four (24) hours in advance.

The District Inspector will arrange for all notification to both residential customers and the fire department; however, the Contractor will be responsible to furnish the Inspector all necessary information as to the date and time the interruption will begin and the total time required to complete the installation.

A normal interruption shall be a maximum of two hours. If the interruption will be greater than two hours, the work shall be done in a manner to minimize the inconvenience to customers, such as working at night in a continuous operation until service is restored. A connection which will require an interruption longer than two hours shall be subject to review by the District as to the appropriate timing of the connection.

If, in the process of installing a connection, there exists an industry or building in the area that cannot be out of water, such as a hospital or other special customer, appropriate means shall be taken to provide and convey water. The water and means of conveyance shall be approved by the District.

5.26 Corrosion Protection Systems.

- a. Dissimilar Materials. Insulation shall be installed as required by the District. Particular care shall be taken to insulate between dissimilar materials.
- b. Insulating Joints. Whenever it is necessary to join pipe of dissimilar metal, or when designated by the District, a method of insulating against the passage of electrical current shall be provided. Special care shall be exercised during the installation of these joints to prevent electrical conductivity across the joints. See Section 4.09 of these Specifications and Standard Drawing No. 11.
- c. Polyethylene Encasement Material. Whenever designated by the District, the metallic pipe and all appurtenances shall be wrapped in polyethylene. The polyethylene encasement shall prevent contact between the pipe and bedding material, but is not intended to be a completely air-tight and water-tight enclosure.

Prolonged exposure to sunlight will eventually deteriorate polyethylene film. Exposure to sunlight shall be kept at a minimum.

The polyethylene shall have a minimum wall thickness of eight (8) mils and conform to the specification set forth in this part.

A 2-inch wide, ten-mil thickness polyethylene pressure-sensitive tape shall be used to close seams, secure to pipe or hold overlaps.

Polyethylene pipe wrap material shall be applied to line pipe in the manner shown on Standard Drawing No. 9.

Damage to polyethylene wrapped pipe in the trench prior to and during backfill shall be repaired to the satisfaction of the District.

Before the Contractor taps a water main, the trench, pipe and polyethylene wrapping shall be in a state of readiness. The Contractor digging the trench shall repair or replace any damaged polyethylene prior to tapping.

d. Insulating from Concrete. Areas of metal pipe and appurtenances which are to be in contact with concrete thrust blocks, bridging blocks, anchors or encasement may be required by the District to be protected against corrosion prior to installing concrete. The following types of protection systems are acceptable:

- (1) Application of cold-applied mastic coating with high electrical resistivity, similar to Roskote Mastic A-51, manufactured by Royston Laboratories.
- (2) Application of a cold-applied primer and corrosion resistant pipe wrap, similar to the primer and pipe tape manufactured by the Protecto Wrap Company.

Other proposed protection systems may be accepted following review and approval of the District.

5.27 Disinfection. The following procedure shall apply to all main extensions within the District's water service area. Pipe extensions shall be chlorinated in accordance with AWWA C651, "Disinfecting Water Mains." The Contractor shall provide material for disinfection of all water mains.

Calcium hypochlorite granules with a minimum of 65 percent available chlorine or 5-g calcium hypochlorite tablets shall be used for disinfection. Application rates shall comply with AWWA C651.

The following table denotes the amount of calcium hypochlorite granules to be placed at the beginning and end of the main and at 500-foot intervals to obtain disinfection.

<u>Pipe Size</u>	<u>Calcium Hypochlorite Granules (ozs.)</u>
4"	0.5
6"	1.0
8"	2.0
12" 4.0	

The following table denotes the number of 5-g calcium hypochlorite tablets required per 20-foot joint for dose of 25 mg/l.

<u>Pipe Size</u>	<u>No. of Tablets</u>
4"	1
6"	1
8"	2
10" 3	
12" 4	

After the calcium hypochlorite has been placed in the pipeline by the Contractor, disinfection must be completed within ten (10) calendar days.

After the pipe is filled with water and chlorine, and unless approved otherwise by the District, the chlorinated water shall be held in contact with the pipe for twenty-four (24) hours. At the end of the twenty-four (24) hour period, the water in the pipeline shall be tested by the District to ensure a residual chlorine content of not less than ten (10) mg/l.

The pipeline shall then be thoroughly flushed to remove the heavily chlorinated water. Care shall be taken in flushing the pipeline to prevent property damage and danger to the public.

Samples of water will be collected for bacteriological examination and residual chlorine content testing before the pipe is put into service. Testing of residual chlorine and sampling will be done by the Contractor. The Contractor will be responsible for all testing unless other arrangements have been made with the District

No main which has been disinfected and flushed shall stand stagnant for more than fifteen (15) days without being re-flushed.

- 5.28 Pressure Testing. All mains and appurtenances shall be subject to pressure testing performed by the Contractor. All mains shall be subjected to a test pressure of 1.5 times the static pressure at the lowest point in the portion of the system being constructed. The test pressure shall be placed on the pipeline and the line isolated from other water sources. After a two (2) hour period, water shall be added to the line to return the pressure to the specified test pressure. The quantity of water required to return the pressure to the specified level will be measured.

The maximum allowable leakage at the specified test pressure shall not exceed ten (10) gallons per day per inch of pipe diameter (inside diameter) per mile of pipe.

ALLOWABLE LEAKAGE

<u>Pipe Diameter</u>	<u>Allowable leakage in 2 hours, Gallons</u>			
	<u>250 ft.</u>	<u>500 ft.</u>	<u>750 ft.</u>	<u>1000 ft.</u>
6"	0.24	0.47	0.71	0.95
8"	0.32	0.63	0.95	1.26
10"	0.39	0.79	1.18	1.58
12"	0.47	0.95	1.42	1.89

- 5.29 Acceptance and Release for Taps. A new main shall be accepted by the District and released for taps when the following conditions have been met:
- a. The main and all appurtenances have been installed to the satisfaction of the Inspector and all pertinent notes and measurements have been made.
 - b. Disinfection has been completed and the main has been flushed, charged and received a passing bacteriological test.
 - c. Pressure testing has been completed satisfactorily.
 - d. All tapping methods have been approved by the District.
 - e. As constructed record drawings and other supporting information shall be furnished to the District within two weeks of the completion of construction of any pipeline segment. The District shall find the record documents satisfactory before permitting the main to be put in service and accepted for maintenance.

5.30 Acceptance of Mains and Service Lines Including Curb Stops.

- a. Preliminary Acceptance. Preliminary acceptance of mains will be granted by the District following the Developer's completion of all curbs, gutters, grading and paving, plus all curb stop

and street valve boxes being set at proper grade.

- b. Final Acceptance. Approximately one year following the preliminary acceptance, the District will reinspect the curb stop and street valve boxes for centering, plumb and grade. The Contractor and Developer will be notified of any defects in materials and workmanship and these defects must be promptly corrected in accordance with these Specifications. Corrections must be made immediately. If no defects are found or corrections are made as required by the Inspector, a letter of acceptance will be issued, following receipt of proper documents giving clear title to all mains and appurtenances. Service lines beyond the corporation stop on the main are the property of the Developer and/or Owner. Preliminary and final acceptance can be granted in phases of development after all the conditions of current specifications have been met.

The Developer shall be responsible for repairing any deficiencies in the workmanship for a period of one year after preliminary acceptance. This shall include but not necessarily be limited to removal and replacement of surfacing materials (pavement, curb and gutter, sidewalk) which are damaged due to soil settlement.

- c. Repair and Maintenance prior to Final Acceptance. Repair and maintenance of mains and services prior to final acceptance by the District will be the sole responsibility of the Developer and/or Contractor. Repair and maintenance will be accomplished to the current specifications of the District.
- d. Meters. Meters will be maintained by the District from the time of installation.

WATER SYSTEM STANDARD SPECIFICATIONS

Chapter 6 - Service Lines and Meters

6.01 All New Service Lines and, Where Applicable, Service Line Replacements.

- a. Required water plans (see Chapter 2) must be approved by the District and all water connection and tapping charges due must be paid before water taps will be made. All replacement water taps are subject to the water tap fee unless otherwise approved by the District.
- b. Tapping permits must be applied for at the District Office located at 15850 Holbein Drive, Colorado Springs, Colorado, 80921, telephone (719) 488-3603 and paid for at least 24 hours prior to tapping.
- c. All service taps on water mains within the water distribution system shall be accomplished by the Contractor, who shall notify the District a minimum of 48 hours prior to tapping.
- d. No water taps shall be made unless property corners are clearly marked so measurements of taps and curb boxes can be made at the time of tapping.
- e. Excavation of the tapping hole is the responsibility of the Contractor and shall be done in accordance with these Standard Specifications.
- f. Minimum normal size tap for a water service is 1 inch. The Contractor shall be responsible for furnishing all necessary materials. For service line sizes in excess of 2 inches, the corporation shall be a tapping valve and the curb stop shall be a gate valve.
- g. Cribbing, sheeting or sloping of the banks of tapping holes is the responsibility of the Contractor and will be in accordance with the rules and regulations of the State of Colorado, District of Labor and Employment, 200 West 19th Street, Denver, Colorado 80203, and OSHA as applicable.
- h. Barricading of tapping holes is the responsibility of the Contractor and shall be in accordance with construction, installation and repair of right-of-way openings for subsurface utilities for work within the Donala Water and Sanitation District or other applicable regulatory agency.
- i. Backfilling and compaction of tapping holes shall meet the specifications of the governing body in whose jurisdiction work is being done; i.e., Donala Water and Sanitation District, El Paso County or State of Colorado.

- j. Replacement of Existing Corporation Stops: Where an existing corporation stop is to be replaced with a new corporation stop of equal or larger size, the Owner of the property shall be responsible, at his/her expense, to have the old corporation stop excavated and shall contact the District which will shut off the old corporation at no expense to the Owner. Backfill, compaction and replacing of the corporation stop following shut off by the District is the responsibility of the property Owner at his/her expense.
- k. Abandoning Existing Taps: Where an existing water tap is to be abandoned, the Owner of the property shall be responsible, at his/her expense, to have the corporation stop excavated and then contact the District which will shut off the corporation at no expense to the Owner. Backfill and compaction will be the responsibility of the property Owner at his/her expense.
- l. Multiple Service Taps: No service line within the District's water service area will serve more than one customer. Each house, building or business shall have an individual tap and service line from the water main to the house, building or business, and an individual meter.

6.02 Water Service Line Excavations for All New and Replacement Service Lines.

- a. Excavation, safety and backfilling to include proper compaction of water service line ditches are the responsibility of the Contractor all in accordance with the specifications of the governing body in whose jurisdiction the work is being done; i.e., Donala Water and Sanitation District, El Paso County or State of Colorado.
- b. Water service line ditches must enter the lot as near ninety degrees (90°) to the property line as is practical and not at an extreme angle unless otherwise approved.
- c. Water Service Line Ditches and Separation of Water Service and Building Sewer: Except as permitted below, the water service line and the building drain or building sewer shall be not less than 10 feet apart horizontally and shall be separated by undisturbed or compacted earth. Such a separation shall be maintained in all public rights-of-way and easements. The water service line may be placed in the same trench with the building drain or building sewer provided approval is given by the District and the following conditions are met:
 - (1) The bottom of the water service line at all points shall be at least 18 inches above the top of the sewer line at its highest point. The water service line and building sewer shall be separated by a clear horizontal distance of no less than 24 inches.
 - (2) The water service line shall be placed on a solid shelf excavated at one side of the common trench.
 - (3) No joints in the water service line shall be permitted between the corporation stop and the curb stop without prior approval of the District. In no case will soldered joints be allowed.

- (4) The materials and joints of sewer and water service lines shall be installed in such a manner and shall possess the necessary strength and durability to prevent the escape of solids, liquids and gases there from under all known adverse conditions such as corrosion, strains due to temperature changes, settlement, vibrations and superimposed loads.

6.03 Service Line Installation and Material for All New and Replacement Service Lines.

- a. New and existing service lines
 - 1) An expansion loop as shown on the Standard Drawings (3/4-inch through 2-inch only) must be left in the service line where it is connected to the corporation stop at the water main to allow for expansion and contraction.
 - 2) Existing water services or taps which are not 3/4-inch or larger and do not consist of high-density polyethylene (HDPE) pipe or that will not meet the specifications referred to in this section will not be permitted.
 - 3) If the existing tap has been deleted from the water system at the time of demolition, under no circumstances will the District allow a service to be reconnected. It would constitute a new tap and service.
- b. Water service lines shall conform to the following minimum diameter
 - 1) 3/4-inch diameter for townhomes (attached single family) and patio homes
 - 2) 1-inch diameter for single family residential
 - 3) Multi-family and commercial service lines shall be sized in accordance with the applicable local building code and subject to the review and approval of the District
 - 4) Minimum diameters described above may be increased to provide for satisfactory delivery pressures as determined by the District
- c. Water service line material
 - 1) HDPE Pipe: High Density PE 3608/3408 IPS
 - 2) Conformance: ASTM D 2239; AWWA C 901
 - 3) Dimension Ratio: SIDR 7
 - 4) Minimum Working Pressure Rating: 200 psi
- d. Water service line joints
 - 1) HDPE pipe shall have heat fusion joining in accordance with ASTM F 2620
- e. All water service lines shall have a minimum cover of 5 feet except at the expansion loop and will be determined by the street cut and/or by the finished grade of the property.
- f. Water service lines from the corporation to the curb stop shall have a maximum cover of 6 feet unless otherwise approved.
- g. Where a 1-1/2-inch or larger water service line crosses another utility or any underground structure, the water service line shall preferably pass over the other utility or structure, but in no instance shall there be less than 6 inches clearance between the water service and the other utility or structure. The space between the water service line and the utility or structure shall be backfilled with sand when the clearance is less than 12 inches.

Where any water service line passes under a sewer main, the sewer main shall be constructed of cast iron or Schedule 40 polyvinyl chloride (PVC) pipe for 6 feet each side of the water service line.

- h. Tapping saddle: A tapping saddle shall be used on all service line connections to the water distribution system. Tapping saddles shall have the following characteristics:

- (1) Stainless steel bands
 - (2) Nylon coated ductile iron body
 - (3) Nylon coated body (10-12 mil)
 - (4) AWWA tapered thread pattern (cc)
 - (5) Acceptable manufacturer: Mueller[®] Co., Model DR2S or approved equal
- i. Corporation stop
- (1) Conform to AWWA C800
 - (2) AWWA tapered thread pattern inlet (cc) x IPS PE
 - (3) Compression McGrip for PEP Tubing
 - (4) Same size inlet and outlet ¾" & 1" 74701B-3G, 1-1/2" & 2" 74701-33
 - (5) Acceptable manufacturers: AY McDonald
 - (6) Stainless Steel Inserts to be used at all connections. IPS
- j. New service lines on single family units will be installed to enter the property 10 feet inside the front property line farthest from the garage and/or driveway unless otherwise approved by the District.

6.04 Curb Stop and Curb Box for All New and Replacement Service Lines.

- a. All service lines, regardless of size, must have a curb stop and curb box installed in accordance with the Standard Drawings. The curb box shall be centered over the curb stop and shall be plumb. The following location will be accepted by the District:
- All curb stop boxes will be installed 6 inches from the public right-of-way line unless designated otherwise by the District.
- b. The curb stop supplied by the Contractor shall be installed in accordance with of these Specifications.
- c. The responsibility of the Contractor for the curb box ends only when sidewalks, curbs, driveways, etc. have been installed and all backfilling and compaction has been completed. They are subject to review for alignment at the end of the one-year warranty period.
- d. Curb stops: AY McDonald ¾ & 1 76100-3G, 1-1/2 & 2 71600-33 Stainless Steel Inserts to be used with all connections. IPS
- e. Curb boxes: Tyler series or equal. Enlarged bases required for 1-1/2-inch and 2-inch curb stops.

6.05 Water Meters - General

- a. All water supplied by the District to a newly developed property must be metered except for fire lines. All water meters shall become the property of the District.
- b. Except as noted in (f) below, all water meters are supplied and installed by the Owner or customer. If repair or replacement is necessary during the warranty period, the replacement meter will be accomplished by the District at the builder's expense. If repair or replacement is necessary after expiration of the warranty period, the District shall accomplish such repair or replacement.
- c. Acceptable locations for 3/4-inch and 1-inch water meters shall be limited to outside water meter pits, basement, utility room or utility closets unless otherwise approved. Locations for 1-1/2-inch or larger water meters shall be approved by the District prior to installation of the water meter loop.
- d. Water meter locations selected shall provide adequate protection against freezing.
- e. Water meters installed in the District shall be the Badger Meter, Inc. "E-Series."
 - (1) 3/4-inch diameter: Model 25
 - (2) 1-inch diameter: Model 55
 - (3) Other sizes: As approved by District
 - (4) Stainless Steel body
- f. The Badger Cellular Beacon Transponder will be installed by the District. The owner/customer will be required to install only the meter noted above.

6.06 Inside Water Meter Installations Only

- a. Inside residential water meter locations must be in the basement or other lowest level of the residence. When installed in a crawl space with an earth floor, a rock-filled sump, 1-1/2' deep, 1-1/2' in diameter shall be installed beneath the meter location. Where plastic pipe is used for inside installations, plastic will not be used within 3 feet of the meter loop.
- b. Inside 3/4-inch and 1-inch water meter locations shall be such that the water meter is unobstructed on one side, easily accessible for reading or servicing, with a minimum of 8 inches clearance around the remainder of the meter with a minimum of 3 feet of clearance above the meter. Meter locations shall not require stooping or crawling to gain access to the meter. Meters will not be installed in attic spaces and shall be on or near the floor. Approval prior to construction for crawl space installation may be granted by the District.
- c. Inside 3/4-inch and 1-inch water meter loop installations shall include an inlet and outlet valve as shown on Standard Drawings. Inlet and outlet valves shall be full opening water way, straight or angle body meter ball valves.
- d. Inside 1-1/2-inch and larger. Plans for inside water meter loop (to include support) installations for 1-1/2-inch and larger water meters shall be submitted to the District for approval prior to installation of the meter loop and should be similar in design to the meter loop piping and support shown on the Standard Drawings except that the bypass piping may also be extended under or over the meter and that adequate meter loop support may require a different design.

- e. Water main installations shall incorporate necessary backflow prevention devices as specified herein.
- f. All water meters shall be installed in a horizontal position.

6.07 Water Meter Pit Installations Only

- a. Pit installation of meters 3/4-inch through 1-inch are not normally acceptable within the District's service area. Any deviations from this policy must be approved in advance by the District on an individual case basis.

The locations of the meter pit for 3/4-inch through 1-inch water meters will be one foot (1') inside of the curb stop. If a problem arises on the location, the location will be determined by the District.

- b. The Standard Drawings may be used as a guide for planning of meter pit installations. All proposed pit installations shall be preapproved by the District prior to start of construction.

6.08 Combined Domestic and Fire Line Water Meters

- a. Only meters approved by the National Board of Fire Underwriters shall be installed in water lines providing both domestic and fire service. Requests to install a meter in a water line providing both domestic and fire demands should be made to the District a minimum of 90 days in advance of construction.
- b. Unless otherwise approved by the District, a combined domestic and fire line meter must be installed in a pit large enough to accommodate the meter, meter bypass and all valves and piping, all in accordance with Standard Drawings.
- c. The location of the meter pit must be approved by the District in advance of construction.
- d. Meter pits must have an approved ring and cover of sufficient size (25-1/2 inches minimum) opening for installation and removal of the meter.
- e. The meter loop (3-inch through 6-inch) must set on the floor of pit, not the riser. The maximum depth of the meter pit (inside dimension) shall be 8 feet. The minimum depth of the meter pit (inside dimension) shall be 7 feet.
- f. Water meter loops for combined domestic and fire line water meters must have both inlet and outlet valves.
- g. Water meters must have a bypass around the meter of sufficient size to supply the property while the meter is being serviced.

6.09 Water Regulators

- a. A water regulator designed for 250 psi shall be installed in all domestic service lines. Refer to the Standard Drawings.
- b. One regulator must be installed upstream of the water meter. The customer may also install another regulator downstream of any irrigation supply branch line, downstream of the meter.
- c. A water regulator for service lines incorporating a 1-1/2-inch or larger meter, where a bypass is

required, shall be installed so that the water passing through the bypass is also regulated into the building.

- d. Water regulators may be located either inside the building or outside the building in a pit (1-1/2-inch service or larger only), at the builder's discretion, subject to the District's approval.

6.10 Inspection of Services for All New and Replacement Service Lines

- a. Water service lines shall be inspected by the District and the inspection shall include an inspection of the service line from the curb stop to the foundation and an inspection of the meter installation to include all of those items contained within Sections 6.01 through 6.10 of these Specifications. The trench backfill compaction shall meet the requirements of these Specifications.

6.11 Repair and Replacement of Existing Service Lines

- a. Responsibility. The property Owner is responsible for the repair and maintenance of the water service line from the curb stop to the house or other building.
- b. Leaks occurring on a water service line between the curb stop and the house or building shall be repaired as necessary to include backfilling and restoration of property at the property owner's expense. However, the District will, if requested to do so, shut off the water service line at the curb stop. To preclude unnecessary waste of water, if repairs are not initiated within a reasonable period of time, the District may, at its discretion, shut off the water service until repairs have been affected.
- c. The property owner is responsible for all damages that may occur to other property, real or personal, including property of the District, that were caused by failure to repair and maintain the water service line, or from leaks occurring on a water service line or from bursting or other failure of the water line.
- d. Leaks occurring between the curb stop and the corporation shall be repaired by the District.
- e. When a doubt exists concerning the location of a leak, the District will determine the general location of the leak. This will be done by turning off the service at the curb stop. When this action causes the leak to stop flowing, the homeowner or property Owner will be responsible for repair of the line at a location between the curb stop and the structure served. When the leak continues to flow after turn off, the District will be responsible for repair of the line at a location between the curb stop and the main.

6.12 Service Line - General Notes

- a. All work on fabrication and installation of meter boxes shall conform to the following codes, latest edition:

Uniform Building Code
Building Code for Reinforced Concrete (ACI)
American Welding Society Specifications

All material or components considered defective by the District shall be rejected and immediately removed from the site at no expense to the District.

The Contractor shall verify and coordinate the dimensions of all openings, meters, inserts, etc.,

with the District and manufacturer.

- b. Concrete: All concrete shall use Type II cement with 6% air entrainment and shall develop a minimum compressive strength of 3000 psi at 28 days.

No concrete shall be placed on frozen ground.

Soil shall be firm and capable of withstanding bearing pressures of 2500 psi DL + LL.

Concrete placed during cold weather shall be protected from freezing for a minimum of seven days.

Shoring shall be provided for slabs and walls until concrete has developed sufficient strength to withstand all imposed loads.

All surfaces shall be sprayed with a combination non-staining cure and seal compound.

All reinforcing shall conform to ASTM A615, Grade 60.

All exterior concrete surfaces shall receive two applications of asphalt waterproofing.

- c. Shop drawings and specifications shall be submitted in triplicate to the District for all concrete reinforcements (cast-in-place), anchor plates, and prefabricated boxes (bituminous fiber and waterproof).
- d. Welded steel anchor plates shall be made of A36 steel with E60 electrode and shall be welded by a certified welder. All surfaces damaged during welding and installation shall be repaired and painted to the satisfaction of the District.
- e. Grouting of concrete walls around pipes and footings as shown on drawings shall be done with non-shrink Embeco grout.
- f. In the event that ground water or other unstable and unusual conditions are encountered, the Contractor shall notify the District immediately for inspection and recommendations for drains, gravel fill, additional reinforcing, etc. Approved rubber water stops shall be used in all concrete joints for conditions where subsurface water is encountered.
- g. Prior to construction, the Contractor shall obtain meter size and dimensions from the District. Regulators must be located in the meter pit or in the building on the supply side or upstream of the meter.
- h. The Contractor, at his/her option, may use 22 gauge galvanized corrugated metal forming for cast-in-place concrete roof slabs. Brief specifications shall be submitted to the District for approval and verification of structural capacity.
- i. A complete set of "as-built" plans consisting of all water mains and service lines will be furnished to the District by the Contractor within fourteen (14) calendar days after completion of each phase of development, and a separate complete set showing all phases of the development will be furnished within thirty (30) calendar days after completion of all phases of the development.

WATER SYSTEM STANDARD SPECIFICATIONS

Chapter 7 - Water Service Quality Control Regulations

- 7.01 General. This document is adopted by the Donala Water and Sanitation District to promote and sustain the high quality of drinking water furnished to the District's water customers; to protect the public potable water supply system of the District from the possibility of contamination or pollution by backflow, back siphonage or backpressure; to promote the elimination or control of existing cross connections, actual or potential; and to provide for the maintenance of a continuing program of cross connection control.
- a. The authority to implement and maintain this program of cross connection control is contained in the following legislative actions:
 - (1) Colorado District of Health Law C.R.S. 1973 Title 25-1-114.
 - (2) Colorado Primary Drinking Water Regulations Section 11.1.2 (Hazardous Cross Connection).
 - (3) Cross Connection Control, Colorado District of Health, 1983.
 - (4) Occupational Safety and Health Administration Federal Register #202 Part 2, Page 22234, Subpart J.
 - (5) U.S. Environmental Protection Agency, Cross Connection Control Manual (1973) E.P.A. - 43070-73-002 Section 3.
 - (6) Uniform Plumbing Code of the International Plumbing and Mechanical Officials, Chapter 10, Sections 1001, 1002, 1003.
 - (7) Donala Water & Sanitation District Resolution.
 - b. Reference manuals adopted for guidelines on cross connection control:
 - (1) Manual of Cross Connection Control, Foundation for Cross Connection Control and Hydraulic Research, University of California.
 - (2) Cross Connection Control, Colorado District of Health.
 - (3) Cross Connection Control Committee, Pacific Northwest Section AWWA Manual of Accepted Procedures and Practices.
 - (4) Recommended Practice for Backflow Prevention and Cross Connection Control AWWA Manual M-14.
 - (5) Definitions of terms used in this regulation are those contained in "Manual of Cross Connection Control," Foundation for Cross Connection Control and Hydraulic Research, University of California.
 - c. General Requirements

- (1) Backflow prevention devices are to be installed in an accessible location to facilitate maintenance, testing and repair. Standard Drawings show various installations.
- (2) All backflow devices shall be installed immediately downstream of the water meter.
- (3) Before installing the backflow prevention device, pipelines should be thoroughly flushed to remove foreign material.
- (4) In no case will it be permissible to have connections or tees between the meter and service line backflow prevention device.
- (5) In no case will it be permissible to connect the relief valve discharge on reduced pressure zone devices into a sump, sewer, drainage ditch, etc.
- (6) Backflow prevention valves are not to be used for the inlet or outlet valve of the water meter. Backflow preventer test cocks should never be used as supply connections and should be plugged except when being tested.
- (7) In order to ensure that backflow prevention devices continue to operate satisfactorily, it will be necessary that they be tested at the time of installation. Testing shall be required on reduced pressure zone devices only. Such tests will be conducted in accordance with AWWA performance standards. The contractor accomplishing installation shall be responsible for initial testing of the new equipment. Reporting of testing procedures and results shall be made by the contractor to the District on forms provided by the District.

Refer to the section titled "Testing and Maintenance" in these Standard Specifications for periodic testing of reduced pressure zone backflow prevention devices.

- (8) Single-family residences and townhomes shall have a double check valve. Schools, restaurants and other commercial buildings and users shall have a reduced pressure zone device. Irrigation systems shall have a reduced pressure zone device with a pressure type vacuum breaker.

d. Standards for Backflow Prevention Devices

- (1) Any backflow prevention device required herein shall be of a model and size approved by the District. The term "APPROVED BACKFLOW PREVENTION DEVICE" shall mean a device that has been manufactured in full conformance with the standards established by the American Water Works Association (AWWA) entitled:

AWWA C506-Standards for Reduced Pressure Principle and Device, current edition, and have met completely the laboratory and field performance specifications of the Foundation for Cross Connection Control and Hydraulic Research (FCCC & HR) of the University of Southern California established by:

Specifications of Backflow Prevention Devices, 7th Edition, August 1985; Revised, or the most current issue.

AWWA and FCCC & HR Standards and Specifications have been adopted by the District. Final approval shall be evidenced by a "Certificate of Approval" issued by an approved testing laboratory certifying full compliance with said AWWA Standards and FCCC & HR Specifications.

- (2) Only "Approved Backflow Prevention Devices" shall be used. In general, the District will consider acceptance of devices manufactured by the following manufacturers:

Ford Meter Box Company
FEBCO
Mueller Co.
Watts

- (3) Backflow devices used on fire lines shall have O.S. & Y. valves and be listed by the National Fire Protection Association.

e. Installation

- (1) Backflow prevention devices shall be installed in accordance with Standard Drawings.
- (2) Backflow prevention device installations shall be inspected and approved for use by the District. Inspections can be scheduled by calling (719) 488-3603.
- (3) All reduced pressure zone backflow devices shall be installed in a horizontal position. Double check valves on residential diameter services may be installed in any position provided the device is accessible for maintenance, removal and replacement. Other installations shall be subject to the individual review and approval of the District.
- (4) A pressure vacuum breaker shall only be used where the device is never subjected to backpressure and installed a minimum of 12 inches above the highest piping or outlet downstream of the device in a manner to preclude backpressure.
- (5) An atmospheric vacuum breaker shall be used only where the device is:
 - (a) never subjected to continuous pressure, and
 - (b) installed on the discharge side of the last control valve and above the point of usage, and

- (c) installed with the air inlet in a level position and a minimum of 6 inches above the highest piping on outlet it is protecting.
 - (6) A single check valve is not considered to be a backflow prevention device.
 - (7) Double check valve assemblies may be installed in below grade vaults when these vaults are properly constructed in accordance with Standard Drawings.
 - (8) Reduced pressure backflow preventers will be installed above ground. The unit should be placed at least 12 inches above the finish grade to allow clearance for the repair work. A concrete slab at finish grade is recommended. Proper drainage should be provided for the relief valve and may be piped away from the location, provided it is readily visible from above grade and the relief valve is separated from the drain line by a minimum of double the diameter of the supply line. A modified vault installation may be used if constructed with ample side clearances. Freezing is a major problem in this area. Precautions should be taken to protect above ground installations.
 - (9) Reduced pressure zone backflow preventer may be installed in a basement provided with an adequate drain with an effective opening of twice the diameter of the device.
- f. Testing and Maintenance
- (1) It will be the duty of the customer/user at any premises where the backflow prevention devices are installed to have certified inspections and operational tests made of the devices at least once per year. In those specific instances where the District deems the hazard to be great enough, it will require certified inspections at more frequent intervals. These inspections and tests shall be at the expense of the water user and shall be performed by water utility personnel or by a certified technician approved by the District, the Colorado Department of Health, or the Water Distribution and Wastewater Collection Systems Certification Council.
 - (2) The customer shall notify the District 48 hours in advance of when the tests are to be performed so that the District's representative may witness the tests if so desired. The devices shall be repaired, overhauled or replaced at the expense of the customer/user whenever the device(s) are found to be defective. Records of all such tests, repairs and overhauls shall be kept, with a copy sent to the District.
 - (3) The customer may request a private certified tester to perform the annual test and furnish the District with a copy of the test, pursuant to the aforementioned stipulation.
 - (4) Existing devices shall be sealed by the technician performing the test at the completion of the test.
 - (5) All testing gauges shall be checked for accuracy and be kept in good operating condition.
 - (6) The District retains the authority to test or otherwise check the installation and operation of any backflow device.
 - (7) The customer may request that the District perform the test for a fee as indicated on the following schedule. The District will not perform any repairs; this must be accomplished by certified personnel from the private sector.

All backflow prevention devices 3/4" - 2"	\$20.00
Reduced pressure assemblies 2" - 10"	\$25.00
Double check assemblies 2" - 10"	\$30.00

g. Right of Entry

The District water utility representative(s) assigned to inspect premises relative to possible hazards shall carry proper credentials of his/her office, upon exhibit of which he or she shall have the right of entry during usual business hours to inspect any and all buildings and premises for cross connections in the performance of his or her duties.

This right of entry shall be a condition of water service in order to provide assurance that the continuation of service to the premises will not constitute a menace to health, safety and welfare of the people throughout the District's potable water distribution system. Where building security is required, the backflow device should be located in an area not subject to security.

h. Violations

- (1) Failure of the customer to cooperate in the installation, maintenance, testing or inspection of backflow prevention devices required by this regulation shall be grounds for the discontinuance of water service to the premises or the requirement for an air-gap separation from the public potable water system.
- (2) Service of water to any premises may be discontinued by the District after written notification if unprotected cross connections exist on the premises, or if any defect is found in an installed backflow prevention device, or if a backflow prevention device has been removed or bypassed. Service shall not be restored until such conditions or defects are corrected.
- (3) Discontinuance of service may be summary, immediate and without written notice whenever, in the judgment of the District's Manager, such action is necessary to protect the purity of the public potable water supply or the safety of the water system.

7.02 Cross Connection Control & Backflow Prevention - Criteria List

a. Abbreviations

A/G - Air Gap Separation
 R/P - Reduced Pressure Zone Device
 D/C - Double Check Valve Assembly
 P.T.V.B. - Pressure Type Vacuum Breaker

b. Type of Establishment

Device Required

Apartments and condominiums - 4 stories or more	R/P
Apartments and condominiums - 4 stories or less	D/C
Auxiliary water systems	R/P
Belted meter installations	R/P
Buildings - 4 stories or more	R/P
Cafeteria, restaurant, or any food handling establishment	R/P
Car Wash	R/P
Child day care center	R/P
Fire Line (toxic chemicals added)	R/P
Fire Line (no chemicals)	D/C
Food processing/packing plant	R/P
Greenhouse R/P	
Hospital, dental or medical facility	R/P
Hotels and motels - single and multi-structures, 3-stories & less	D/C
Irrigation System	R/P - P.T.V.B.
Kennels - dog/cat	R/P
Laboratory- chemical or medical	R/P
Laundromat R/P	
Lease space (shopping centers, warehouse, main water supply)	R/P
Manufacturing/Processing Plant	R/P
Mobile equipment (landscape, lawn, tree spraying, water hauling)	A/G variance by review only
Morgue, mortuary, or autopsy facility	R/P
Nursing home/retirement home	R/P
Office or warehouse except as otherwise described herein	D/C
Pet shops	R/P

<u>Type of Establishment</u>	<u>Device Required</u>
Photo developing lab	R/P
Planned Unit Development	R/P
Plating facilities	R/P
Printing shop	R/P
Private well supply	A/G
Recirculated water	R/P
Reflecting ponds, swimming pools, fountains, open ponds, etc.	R/P
Residences, single-family including townhomes	D/C
Schools - Colleges w/Lab	R/P
Sewage treatment plant	R/P
Solar system	R/P by review
Transportation terminal	R/P
Veterinary Services	R/P

NOTE: Other types of establishments may require protection via air gaps or backflow prevention devices depending on the equipment and/or plumbing arrangements utilized therein. These shall be considered individually, at the discretion of the District. All of the establishments listed below will require review by the District and a determination made as to the need for a backflow prevention device.

Barber shop or college
Beauty shop or college
Buildings - three stories or less
Department store

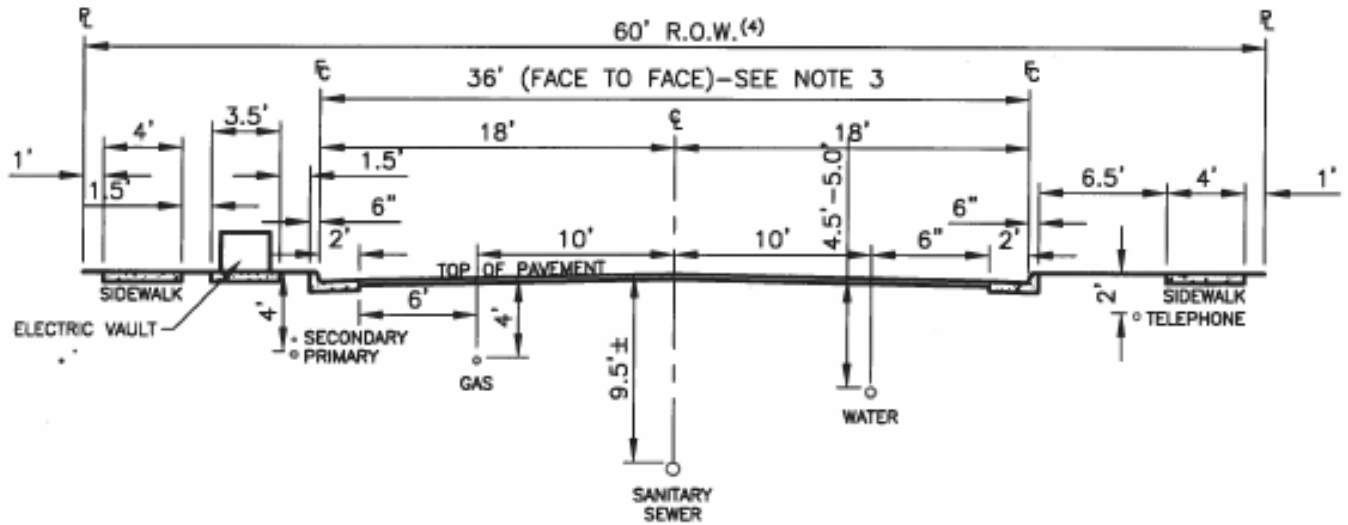

TYPICAL CROSS SECTION
UTILITIES LOCATION

GENERAL NOTES

- 1) STORM SEWERS SHALL MAINTAIN A 10' CLEAR SEPARATION FROM WATER.
- 2) ELECTRIC CONDUITS SHALL BE ON THE OPPOSITE SIDE OF THE STREET FROM WATER.
- 3) FOR 40' WIDE STREET SECTIONS, MAINTAIN WATER 10 FEET FROM SANITARY SEWER AT STREET CENTERLINE.
- 4) FOR 50' WIDE RIGHT-OF-WAY (ROW), A 5-FOOT WIDE SIDEWALK AND UTILITY EASEMENTS ARE REQUIRED ADJACENT TO THE STREET ROW. FIVE (5) FOOT WIDE ATTACHED SIDEWALK IS USED WITH ELECTRIC UTILITIES BEHIND WALK IN EASEMENT.

TYPICAL UTILITIES LOCATION



**DONALA WATER &
SANITATION DISTRICT**

DRAWN: DAB	REVISED:
DATE: JAN. 04	REVISED:
SCALE: 1' = 10'	REVISED:

W-1

DONALA SUB. FILING NO. 1

WATER PLAN

LEGEND

- (H)— EXISTING FIRE HYDRANT
- (H)— INSTALL FIRE HYDRANT
- WATER LINE (ALL WATER LINES LESS THAN 12" SHALL BE DUCTILE IRON UNLESS SPECIFIED OTHERWISE).
- EXISTING WATER LINE
- (X)— EXISTING GATE VALVE
- (X)— INSTALL GATE VALVE
- (A)— INSTALL BLOW-OFF VALVE WITH CONCRETE ANCHOR

WATER STATEMENT

THE UNDERSIGNED OWNER/DEVELOPER AGREES THAT THE INSTALLATION OF THESE PROPOSED WATER FACILITIES WILL BE MADE IN ACCORDANCE WITH DONALA WATER & SANITATION DISTRICT SPECIFICATIONS AND SHALL PROVIDE A MINIMUM OF FIVE FEET (5'-0") AND A MAXIMUM OF SIX FEET (6'-0") OF COVER OVER THE WATER MAIN(S). ANY CHANGES REQUIRED TO MEET THE REQUIREMENTS SHALL BE AT THE EXPENSE OF THE OWNER/DEVELOPER. COVER IN EXCESS OF SIX FEET (6'-0") SHALL BE SUPPORTED BY PLAN AND PROFILE DRAWINGS APPROVED BY THE DISTRICT.

SIGNED _____ DATE _____
OWNER OR DEVELOPER

ALL FIRE HYDRANTS SHALL BE INSTALLED ACCORDING TO THE DISTRICT'S SPECIFICATIONS.

THE NUMBER OF FIRE HYDRANTS AND HYDRANT LOCATIONS AS SHOWN ON THE WATER INSTALLATION PLAN ARE CORRECT AND ADEQUATE TO SATISFY THE FIRE PROTECTION REQUIREMENTS AS SPECIFIED BY THE FIRE DEPARTMENT.

SIGNED _____ DATE _____
DONALA FIRE DEPARTMENT
FIRE DEPARTMENT

WATER INSTALLATIONS CORROSION CONTROL

1. ALL METALLIC COMPONENTS SHALL BE WRAPPED IN POLYETHYLENE TUBING IN ACCORDANCE WITH STANDARD SPECIFICATIONS.
2. ANODES AND ALL OTHER SPECIFIED CORROSION CONTROL MEASURES ARE SHOWN ON THE DETAILED CONSTRUCTION PLANS OR DESCRIBED IN THE STANDARD SPECIFICATIONS.

WATER PLAN APPROVAL

SIGNED _____ DATE _____
DONALA WATER & SANITATION DISTRICT

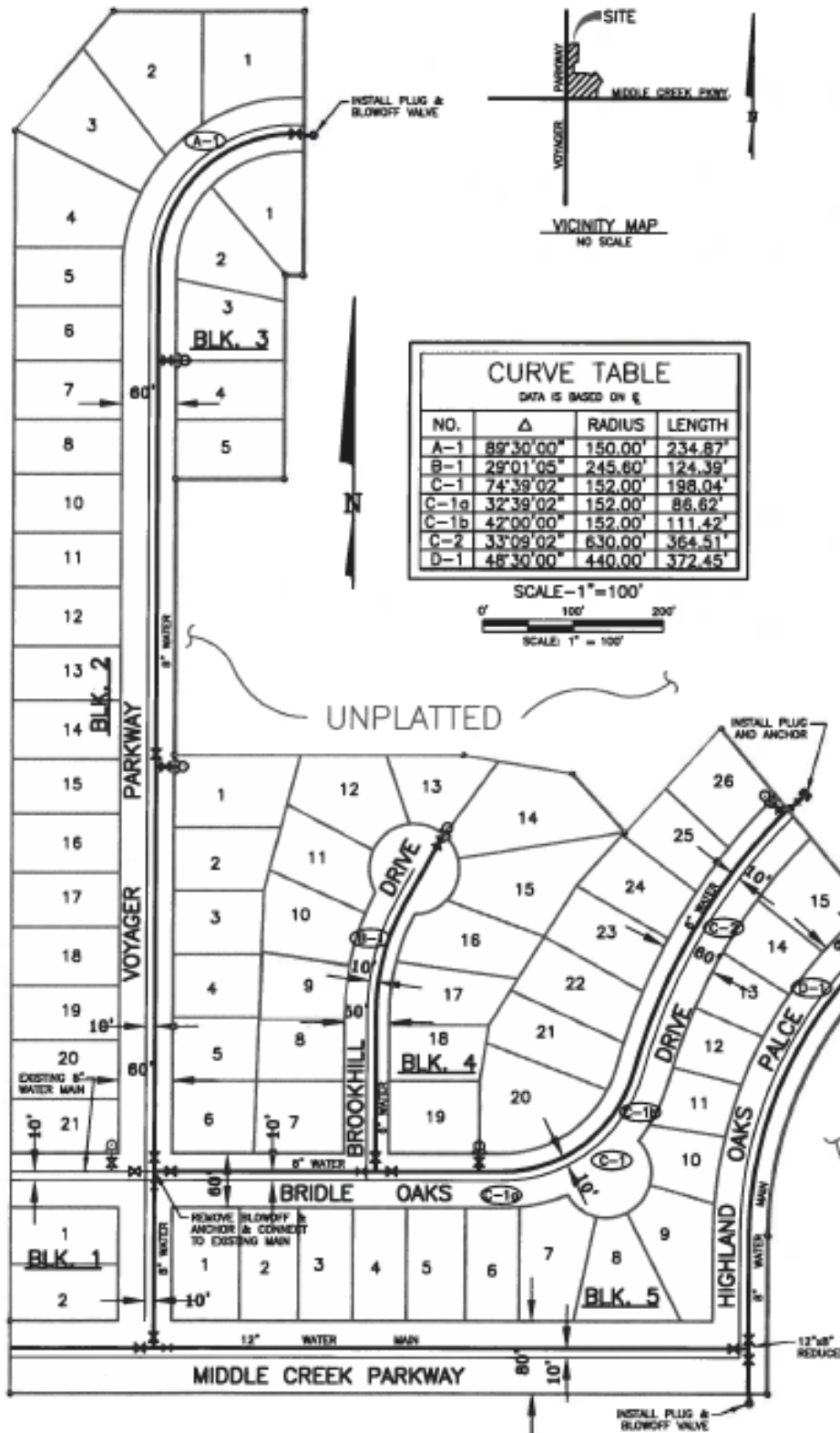

CURVE TABLE			
DATA IS BASED ON E			
NO.	Δ	RADIUS	LENGTH
A-1	89°30'00"	150.00'	234.87'
B-1	29°01'05"	245.60'	124.39'
C-1	74°39'02"	152.00'	198.04'
C-1a	32°39'02"	152.00'	86.62'
C-1b	42°00'00"	152.00'	111.42'
C-2	33°09'02"	630.00'	364.51'
D-1	48°30'00"	440.00'	372.45'

SCALE - 1" = 100'
0' 100' 200'
SCALE: 1" = 100'

1. 60' R-O-W
60' FACE TO FACE OF CURB
4' DETACHED WALK 6' FROM E
3.5' BACK OF CURB TO WALK
THOMPSON AVENUE
2. 60' R-O-W
36' FACE TO FACE OF CURB
4' ATTACHED WALK
7.5' FROM E
SHAWNEY BLVD.
KING ST.
MONTANA ST.
3. 50' R-O-W
30' FACE TO FACE OF CURB
4' ATTACHED WALK
3.5' FROM E
COMMANCHE CT.
4. EXCEPT ON THE END OF ALL
CUL-DE-SACS, RADIUS = 50'
TO E AND 42' FROM FACE OF
CURB, 4' ATTACHED WALK
3.5' FROM BACK OF WALK TO E.

DONALA
SUB. No. 2

TYPICAL WATER PLAN - DISTRICT MAINS

DRAWN: GSM	REVISED:	W-2
DATE: JAN 04	REVISED:	
SCALE: NONE	REVISED:	



G:\DONALASUBS\PECS\Water\Draw-C2.dwg, Layout1, 4/25/2018 4:42:31 PM, sc, Xerox, Altalink C8035, 1:1

BURNBY PARK NO. 1

WATER NOTES

SERVICES SHALL BE INSTALLED IN ACCORDANCE WITH THE DONALA WATER & SANITATION DISTRICT SPECIFICATIONS.

THE UNDERSIGNED OWNER/DEVELOPER AGREES THAT THE INSTALLATION OF THESE PROPOSED WATER FACILITIES WILL BE MADE IN ACCORDANCE WITH THE DONALA WATER & SANITATION DISTRICT SPECIFICATIONS AND SHALL PROVIDE A MINIMUM OF FIVE FEET (5'-0") AND A MAXIMUM OF SIX FEET (6'-0") OF COVER OVER THE WATER MAIN(S). THE UNDERSIGNED UNDERSTANDING THAT ALL WATER MAINS, FIRE HYDRANTS AND APPURTENANCES AS INDICATED ON THIS WATER INSTALLATION PLAN SHALL REMAIN THE PROPERTY OF THE OWNER AND SHALL BE MAINTAINED BY THE OWNER.

SIGNED _____ DATE _____
OWNER OR DEVELOPER

FIRE DEPARTMENT APPROVAL

THE NUMBER OF FIRE HYDRANTS AND HYDRANT LOCATIONS TOGETHER WITH THE MAIN SIZES INDICATED ON THIS WATER INSTALLATION PLAN ARE CORRECT AND ADEQUATE TO SATISFY THE FIRE PROTECTION REQUIREMENTS AS SPECIFIED BY THE FIRE DEPARTMENT.

SIGNED _____ DATE _____
FIRE DEPARTMENT

WATER INSTALLATION CORROSION CONTROL REQUIREMENTS (TO BE DETERMINED PRIOR TO CONSTRUCTION)

- NONE REQUIRED
- REQUIRED, DESCRIBED AS FOLLOWS:

DISTRICT APPROVAL:

SIGNED _____ DATE _____
DONALA WATER & SANITATION DISTRICT

4" METER PIT COMPLETE SHALL BE IN ACCORDANCE WITH THE DISTRICT STANDARDS AND SPECIFICATIONS.

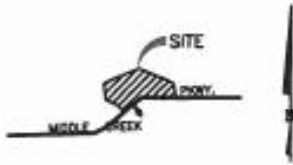

VICINITY MAP
NO SCALE

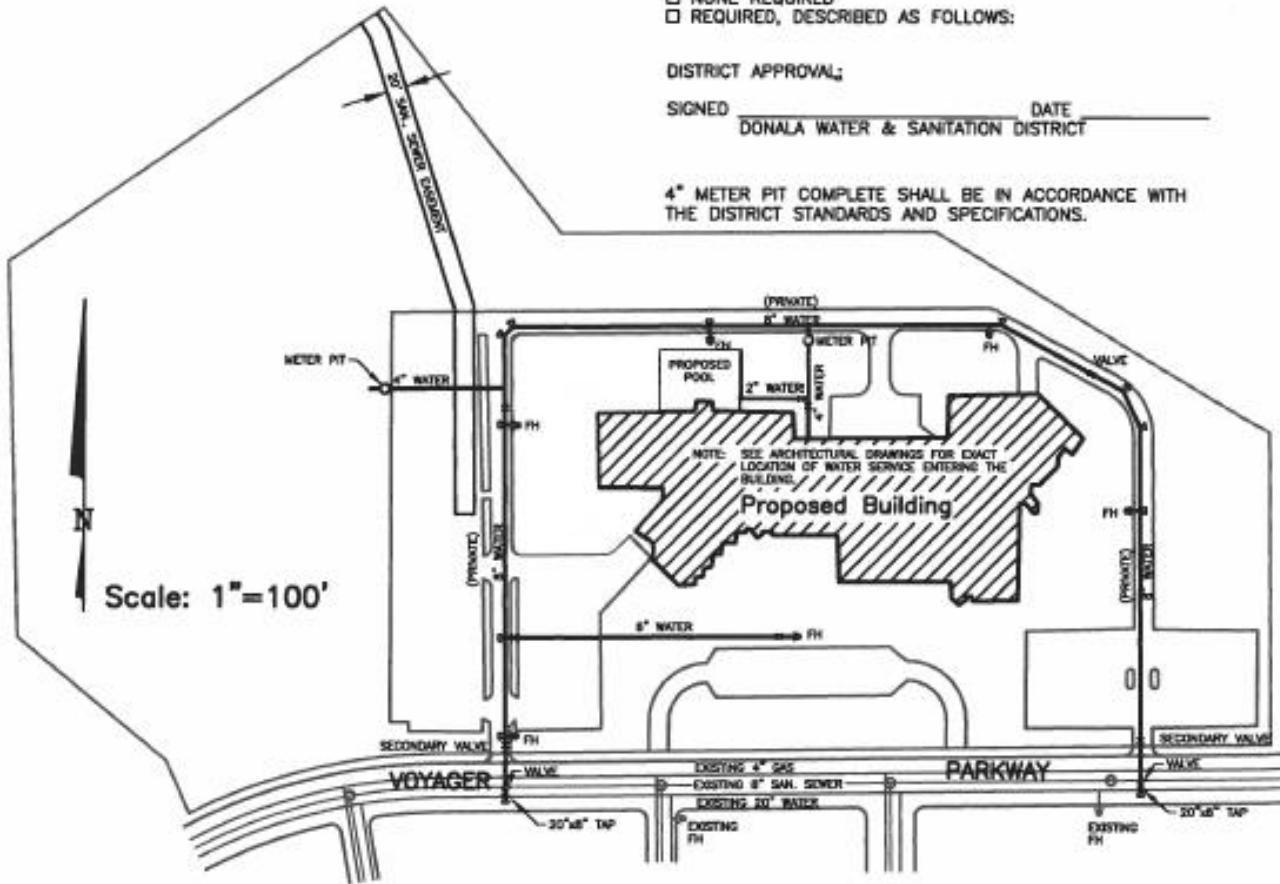

G:\DONAL\A\STD\SPEC\Water\Draw-03.dwg, Layout1_4/28/2018 4:02:14 PM, ac, Xerox Alitlink C8635_1:1



DONALA WATER & SANITATION DISTRICT

TYPICAL WATER PLAN - PRIVATE MAINS

DRAWN: GSM	REVISED:
DATE: JAN. 04	REVISED:
SCALE: NONE	REVISED:

W-3

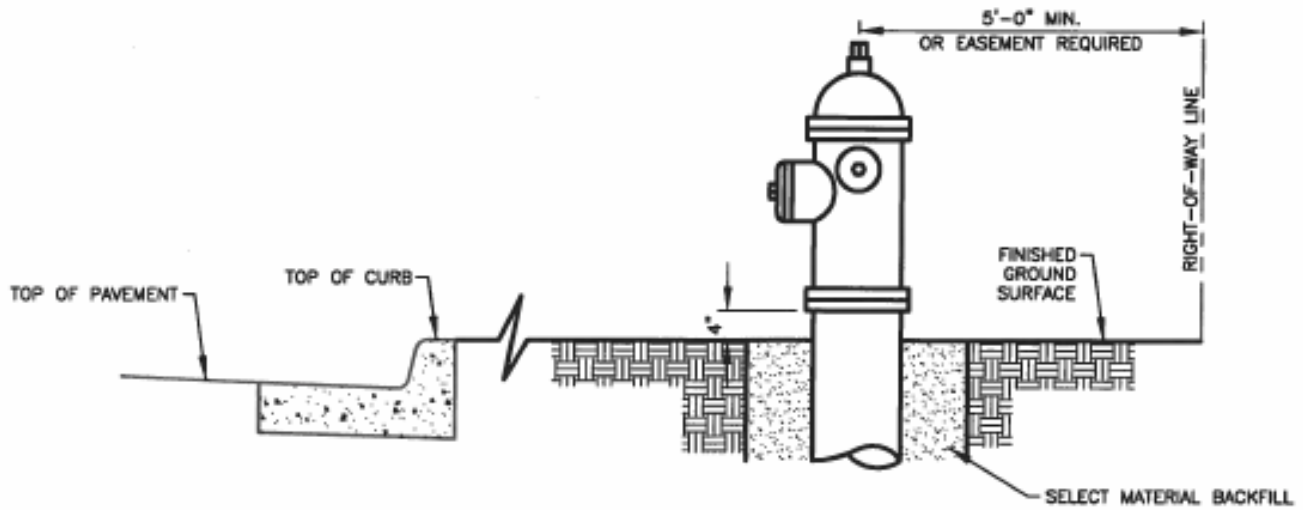

GENERAL NOTES:

- 1) HYDRANT NOZZLE SHALL BE POSITIONED AT RIGHT ANGLES TO THE CURB. IF NO CURB OR SIDEWALK EXISTS, NOZZLE SHALL BE PLACED AT RIGHT ANGLES TO STREET OR ALLEY.
- 2) HYDRANTS INSTALLED AT FLAG LOT LINES SHALL BE OFFSET 3' FROM THE LOT LINE (AWAY FROM STEM).
- 3) HYDRANTS WILL BE PLACED A MINIMUM OF 5.0 FT. FROM ANY UTILITY OR DRAINAGE STRUCTURE.
- 4) EASEMENTS MUST BE PROVIDED FOR ANY PUBLIC HYDRANT WHICH IS CLOSER THAN 5.0 FT TO THE RIGHT-OF-WAY LINE.
- 5) ANY HYDRANTS BEING INSTALLED WITH CONDITIONS OTHER THAN THOSE MENTIONED AND/OR DETAILED BELOW WILL REQUIRE SIGNED APPROVAL FROM THE DONALA WATER AND SANITATION DISTRICT AND THE FIRE DEPARTMENT.

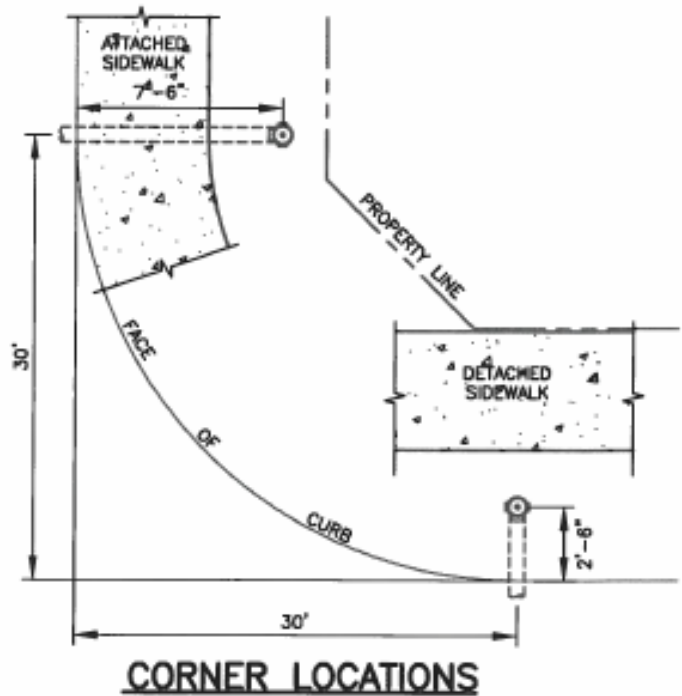
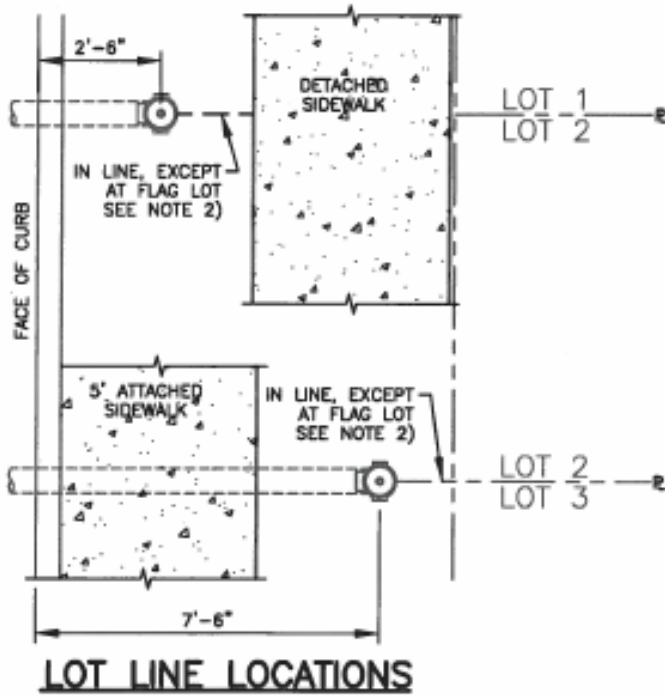

G:\DONALA\A\STD\SPEC\Water\Draw-04.dwg, Layout1, 4/25/2018 4:02:25 PM, sc, Xerox Altalink C88035, 1:1



DONALA WATER & SANITATION DISTRICT

FIRE HYDRANT LOCATIONS

DRAWN: GSM	REVISED:
DATE: JAN. 04	REVISED:
SCALE: NONE	REVISED:

W-4

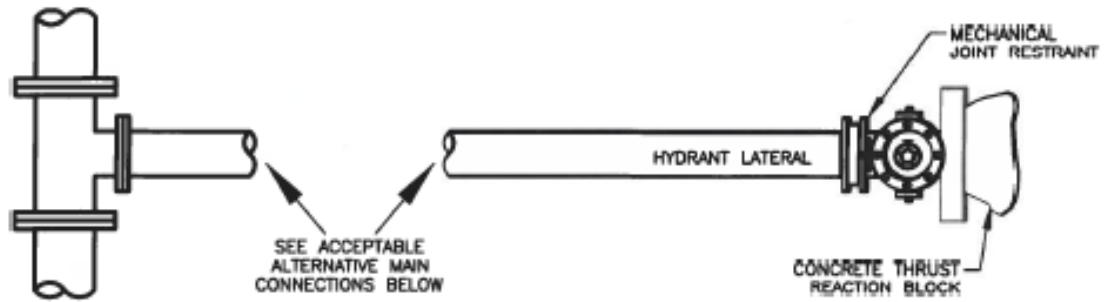

PLAN

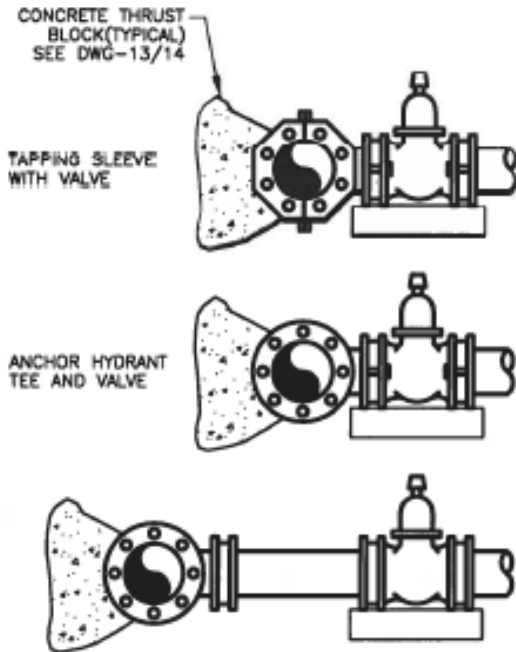

MJ HYDRANT TEE WITH 30° SPACER PIPE AND VALVE. USE MECHANICAL JOINT RESTRAINT AT EACH MECHANICAL JOINT.

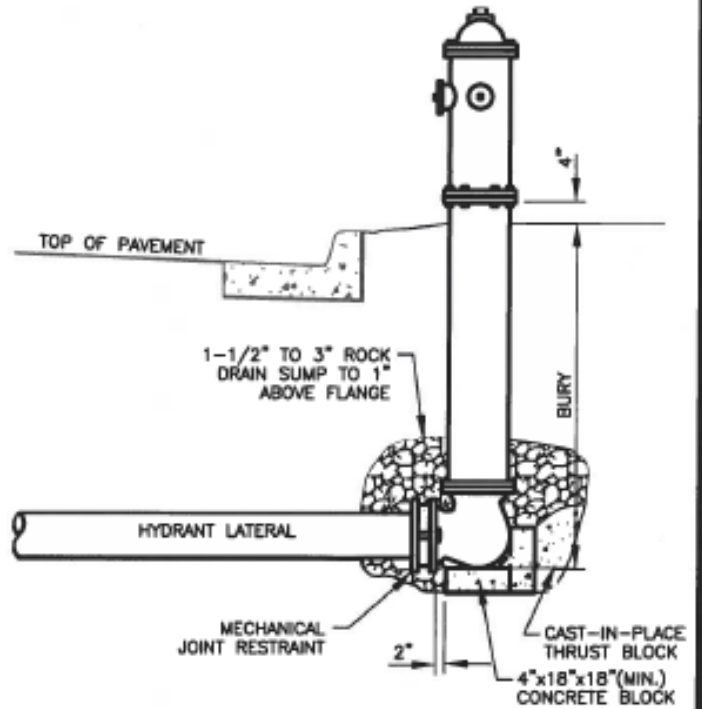

PROFILE

SHOWING 3 ACCEPTABLE VALVE AND TEE FITTINGS

NOTES:

1. TIE BACK RODS:
MAX. ROD LENGTH = 10'
MIN. ROD LENGTH = 4'
2. MECHANICAL JOINT RESTRAINTS SHALL BE USED WITH ANCHOR & TIE RODS AND CONCRETE THRUST BLOCKS.

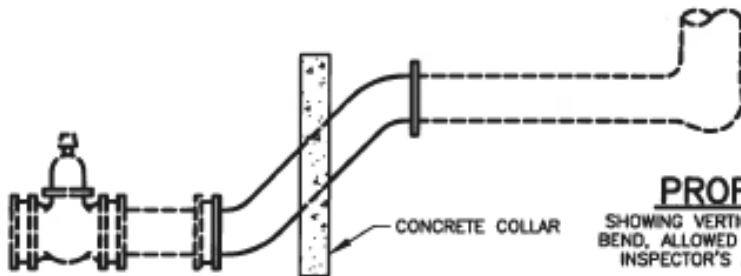

PROFILE

SHOWING VERTICAL OFFSET BEND, ALLOWED ONLY UPON INSPECTOR'S APPROVAL

FIRE HYDRANT INSTALLATION



DONALA WATER & SANITATION DISTRICT

DRAWN: GSM	REVISED:
DATE: JAN. 04	REVISED:
SCALE: NONE	REVISED:

W-5

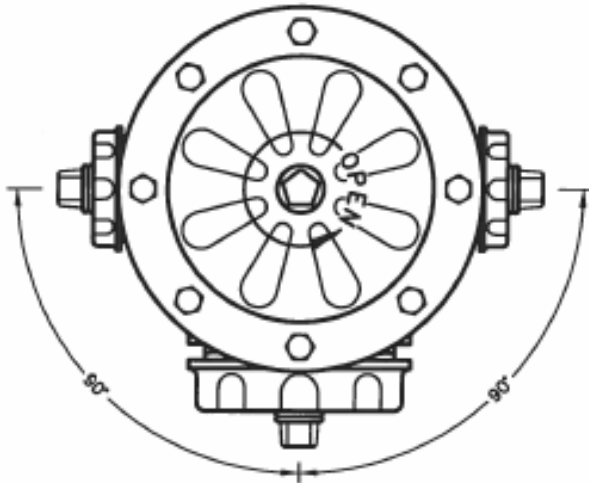

TOP (PLAN) VIEW

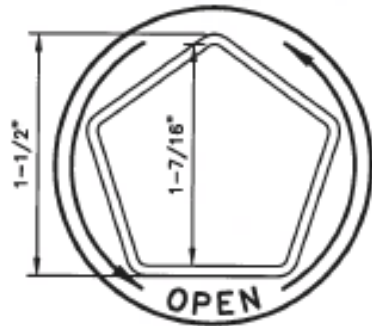

TOP (PLAN) VIEW

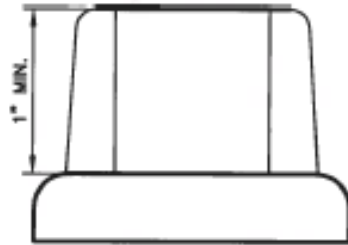

PROFILE
DETAIL 'A'—OPERATING NUT

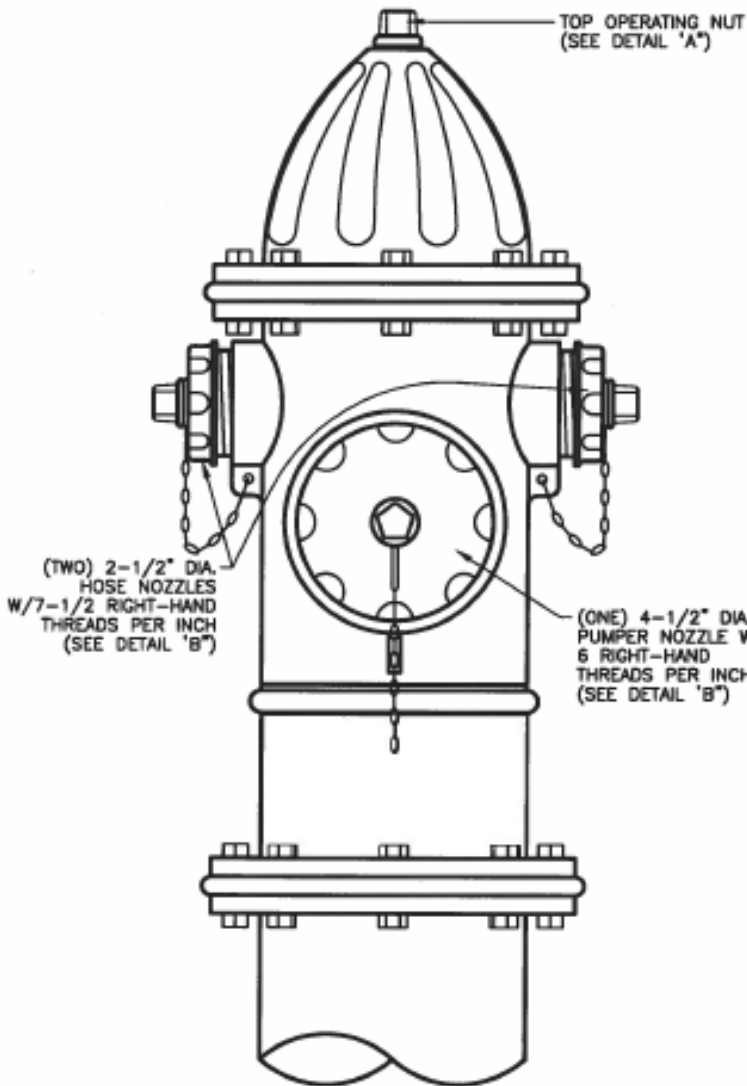

FACE VIEW

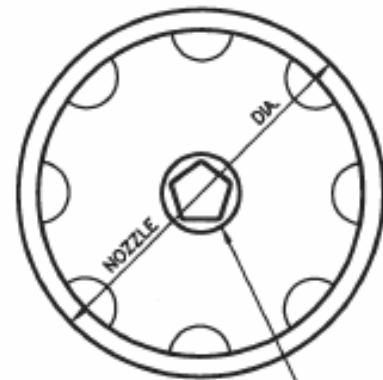

FACE VIEW

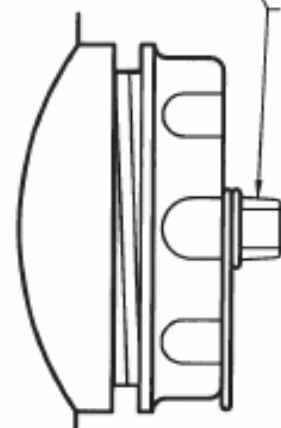

PROFILE
DETAIL 'B'—NOZZLE DETAIL

SEE DETAIL "A"
FOR NUT
DIMENSIONS

(TWO) 2-1/2" DIA.
HOSE NOZZLES
W/7-1/2 RIGHT-HAND
THREADS PER INCH
(SEE DETAIL 'B')

(ONE) 4-1/2" DIA.
PUMPER NOZZLE W/
6 RIGHT-HAND
THREADS PER INCH
(SEE DETAIL 'B')

G:\DONAL\A\STD\SPEC\Wintford\Draw-05.dwg, Layout11_4/28/2018 4:11:38 PM, gc, Xerox, Altablink, C6005, 1:1



DONALA WATER &
SANITATION DISTRICT

FIRE HYDRANT SPECIFICATIONS

DRAWN: GSM	REVISED:
DATE: JAN. 04	REVISED:
SCALE: NONE	REVISED:

W-6

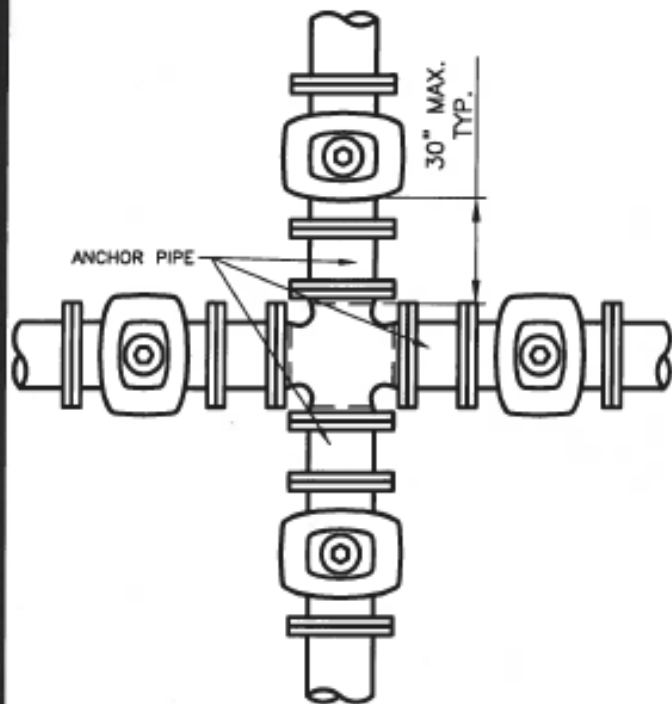

CROSS OR TEE WITH ANCHOR PIPES

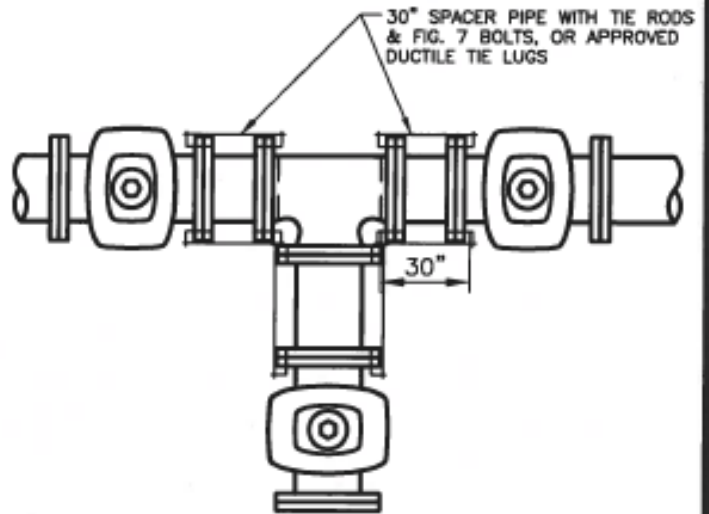

CROSS OR TEE WITH SPACER PIPE & TIE RODS

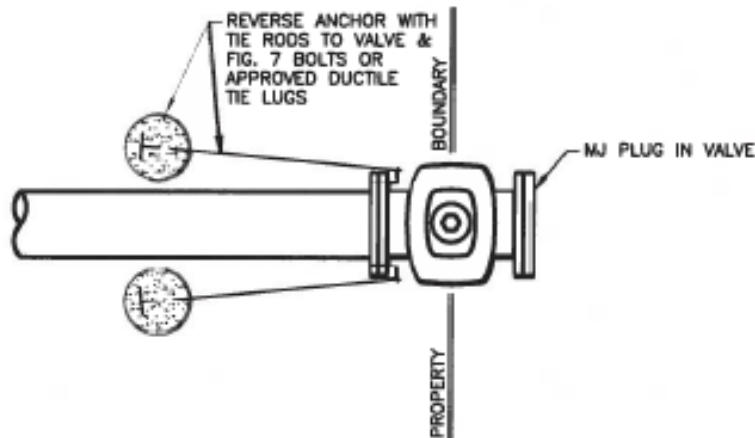

AT END OF LINE USE REVERSE ANCHOR WITH TIE BACK RODS

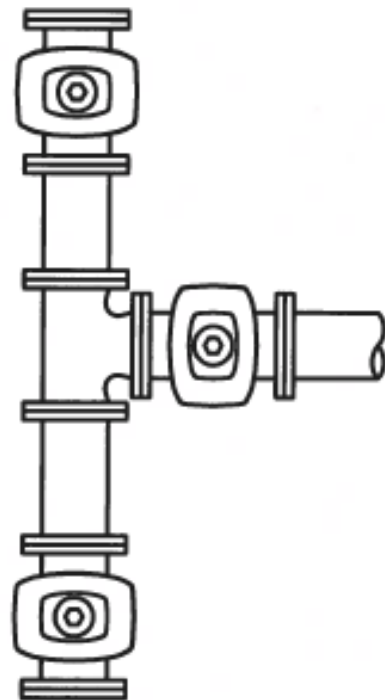

WITH MJ ANCHOR TEE

GENERAL NOTES:

1. ON ANY VALVE INSTALLATION NEAR A FITTING, THE VALVE SHALL BE ANCHORED BY RODS, REVERSE ANCHOR AND MECHANICAL JOINT RESTRAINTS. 3/4" ALL-THREAD RODS SHALL BE USED WITH FIG. 7 BOLTS OR APPROVED DUCTILE TIE LUGS FOR DEAD END VALVES AND/OR PLUGS. ALL METALLIC COMPONENTS SHALL BE WRAPPED IN POLYETHYLENE TUBING.
2. ANCHOR PIPE OR FOSTER COUPLINGS MAY BE SUBSTITUTED FOR SPACER PIPE AND RODS.
3. THE CONCRETE REVERSE ANCHORS USED SHALL BE SIZED AS INDICATED ON 18.
4. SEE 27 & 28 FOR APPLICATION OF MECHANICAL JOINT RESTRAINTS.
5. SEE 8 FOR VALVE BOX INSTALLATION.



DONALA WATER & SANITATION DISTRICT

VALVE INSTALLATION & LOCATION

DRAWN: GSM	REVISED:
DATE: JAN. 04	REVISED:
SCALE: NONE	REVISED:

W-7

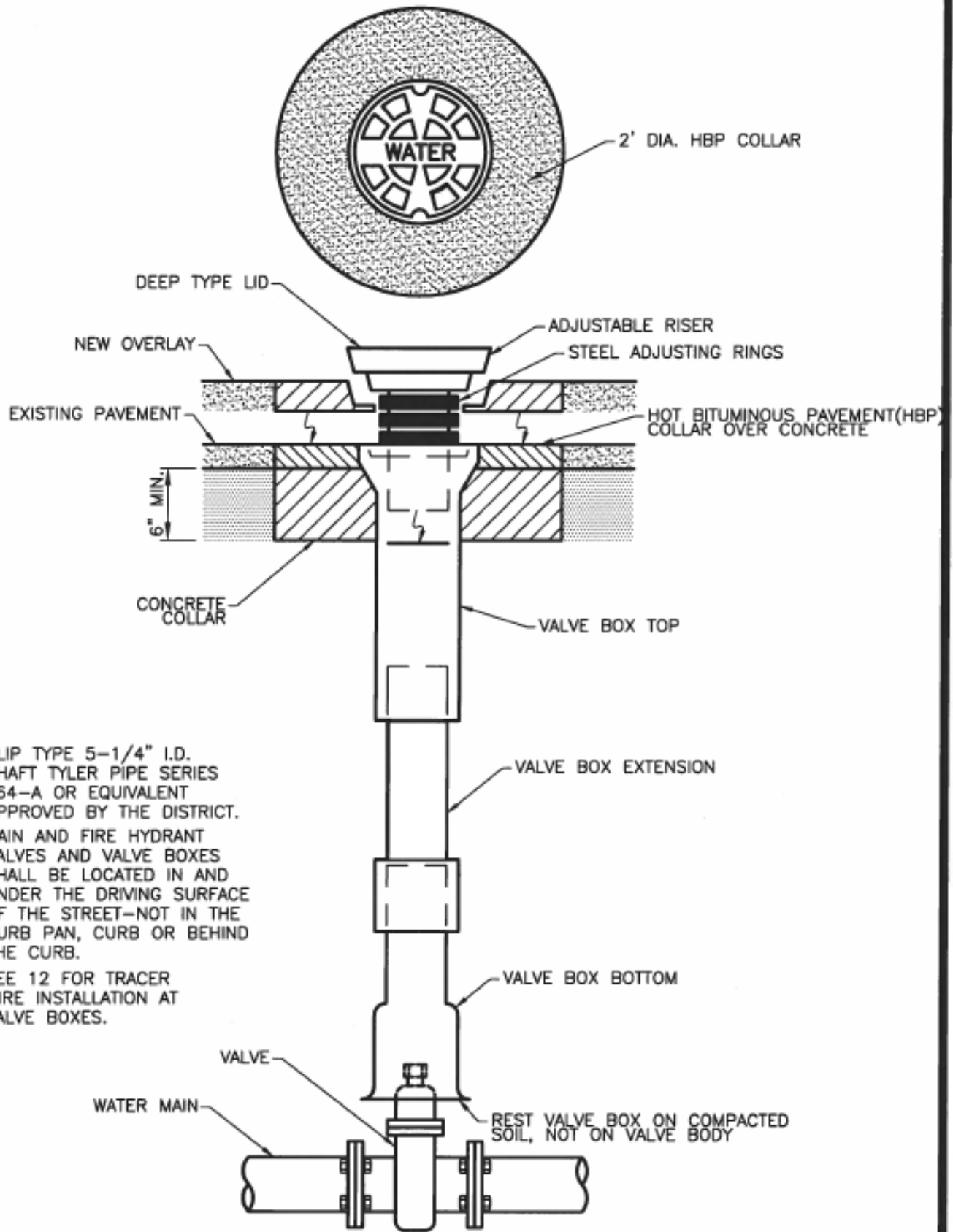

NOTE:

1. SLIP TYPE 5-1/4" I.D. SHAFT TYLER PIPE SERIES 664-A OR EQUIVALENT APPROVED BY THE DISTRICT.
2. MAIN AND FIRE HYDRANT VALVES AND VALVE BOXES SHALL BE LOCATED IN AND UNDER THE DRIVING SURFACE OF THE STREET—NOT IN THE CURB PAN, CURB OR BEHIND THE CURB.
3. SEE 12 FOR TRACER WIRE INSTALLATION AT VALVE BOXES.

REST VALVE BOX ON COMPACTED SOIL, NOT ON VALVE BODY

VALVE BOX INSTALLATION



DONALA WATER & SANITATION DISTRICT

DRAWN: GSM

REVISED:

DATE: JAN. 04

REVISED:

SCALE: NONE

REVISED:

W-8

FIELD INSTALLATION OF POLYETHYLENE WRAP

STEP 1:

PLACE TUBE OF POLYETHYLENE MATERIAL ON PIPE PRIOR TO LOWERING IT INTO TRENCH.

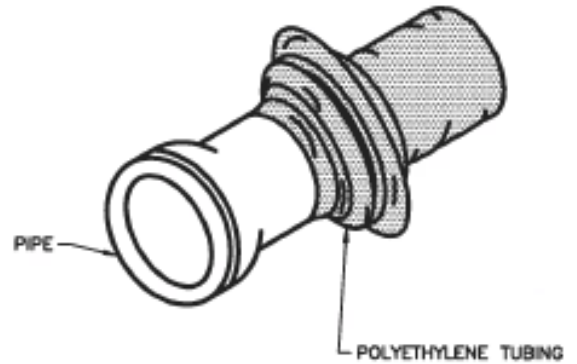

STEP 2:

PULL TUBE OVER THE LENGTH OF THE PIPE. TAPE TUBE TO END AT JOINT. FOLD MATERIAL AROUND THE ADJACENT SPIGOT END AND WRAP WITH TAPE TO HOLD THE PLASTIC TUBE IN PLACE. INSTALL BONDING STRAP OR WIRE AT EVERY JOINT OF PIPE PRIOR TO WRAPPING IN ACCORDANCE WITH THE STANDARD SPECIFICATIONS.

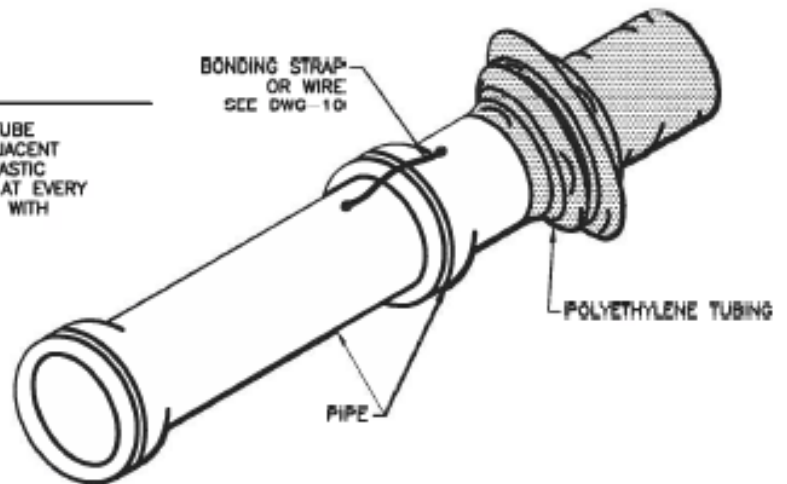

STEP 3:

OVERLAP FIRST TUBE WITH ADJACENT TUBE AND SECURE WITH PLASTIC ADHESIVE TAPE. THE POLYETHYLENE TUBE MATERIAL COVERING THE PIPE SHALL BE LOOSE. EXCESS MATERIAL SHALL BE NEATLY DRAWN UP AROUND THE PIPE BARREL, FOLDED ON TOP OF PIPE AND TAPED IN PLACE.

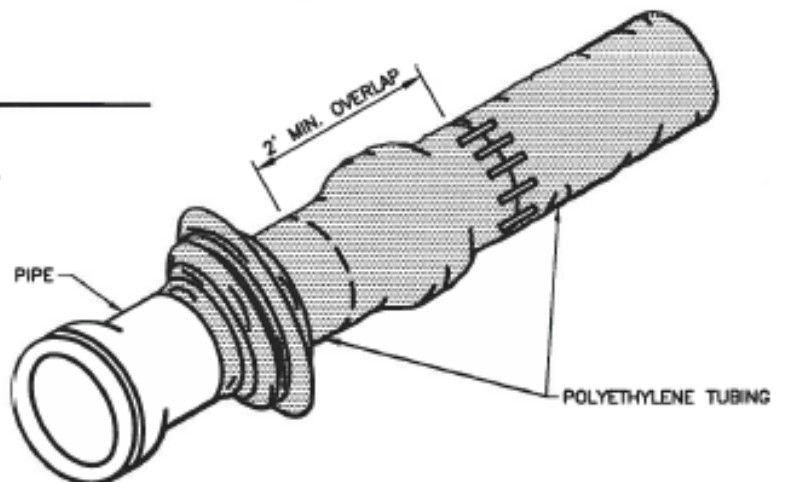

POLYETHYLENE WRAP



DONALA WATER & SANITATION DISTRICT

DRAWN: GSM

REVISED:

DATE: JAN. 04

REVISED:

SCALE: NONE

REVISED:

W-9

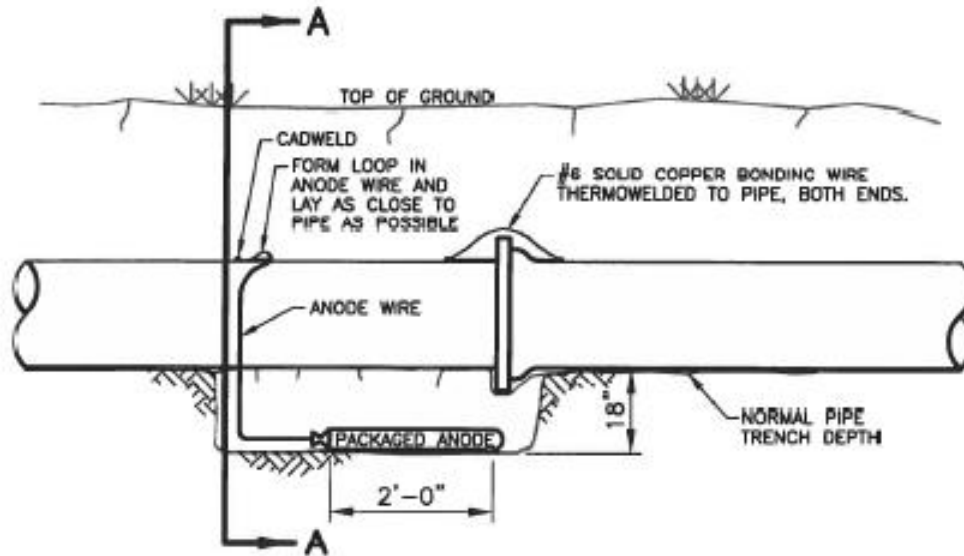

ELEVATION

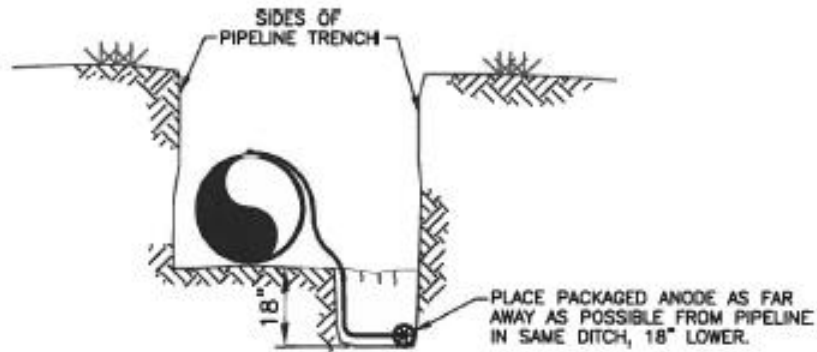

NOTE:

1. CADWELD CONNECTION TO BE PRIMED AND COATED CAREFULLY. PACKAGED ANODE SHOULD BE COVERED WITH FINE SOIL CONTAINING NO ROCKS OR DIRT CLUMPS, TAMPED.
2. WHEN ANODES ARE REQUIRED WITH METAL FITTINGS AND APPURTENANCES TOGETHER WITH PVC PIPE INSTALLATION, THE ANODES SHALL BE PLACED AND ATTACHED TO THE METAL IN SAME MANNER AS SHOWN ON THIS DRAWING. 9LB. ANODES CAN BE USED ON METAL FITTINGS WHEN USING PVC PIPE.
3. PACKAGED ANODE TO BE WETTED AND COVERED WITH SOIL PRIOR TO BACKFILLING.

SECTION A-A



DONALA WATER & SANITATION DISTRICT

BONDING JOINT AND ANODE INSTALLATION

DRAWN: GSM	REVISED:
DATE: JAN. 04	REVISED:
SCALE: NONE	REVISED:

W-10

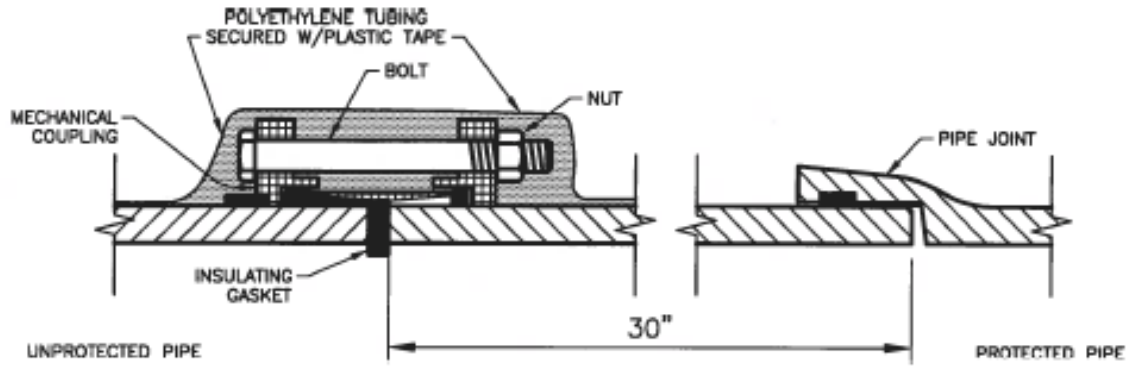

INSULATED MECHANICAL COUPLING

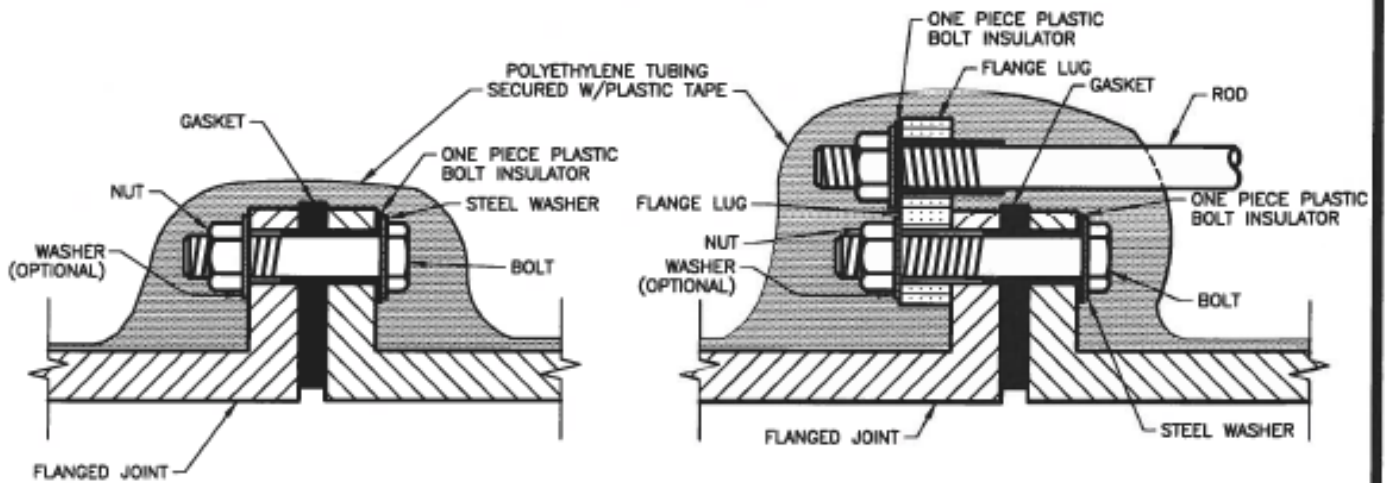

INSULATED FLANGE JOINT

INSULATED TIE BACK ROD

NOTE:

TEST WIRES TO BE USED WHEN REQUIRED.



DONALA WATER & SANITATION DISTRICT

INSULATOR INSTALLATION

DRAWN: GSM	REVISED:
DATE: JAN. 04	REVISED:
SCALE: NONE	REVISED:

W-11

FINISH GRADE

INSTALL A SINGLE STRAND (NO LOOPS) OF COPPER WIRE TO THE TOP OF VALVE BOX ALONG THE INSIDE OF UPPER VALVE BOX SECTION

TYPICAL VALVE BOX

THERMOWELD OR USE A No. 6 COPPER CONNECTOR, TYPE BURNDY No. YC6 OR EQUAL

THERMOWELD OR USE A No. 6 COPPER CONNECTOR, TYPE DOSSERT No. DPC2, HOMAC No. C6 OR EQUAL (SEE DETAIL 'A' THIS SHEET)

PLASTIC

PIPE

TYPICAL VALVE

USE No. 6 COPPER TIE WIRE

COPPER WIRE MUST BE TAPED TO TOP OF PIPE EVERY 3 TO 4 FEET

WIRE TO BE TAPED ON EACH SIDE OF EVERY JOINT

THERMOWELD OR USE A No. 6 COPPER CONNECTOR, TYPE BURNDY No. YC6 OR EQUAL FOR TEE CONNECTION (SEE DETAIL 'B' THIS SHEET) OUTSIDE POLYWRAP

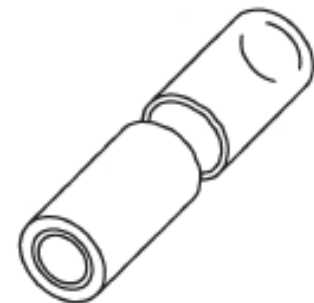

DETAIL 'A'



DETAIL 'B'



DONALA WATER & SANITATION DISTRICT

COPPER TRACER WIRE ON PVC SERVICE

DRAWN: GSM

REVISED:

DATE: JAN. 04

REVISED:

SCALE: NONE

REVISED:

W-12

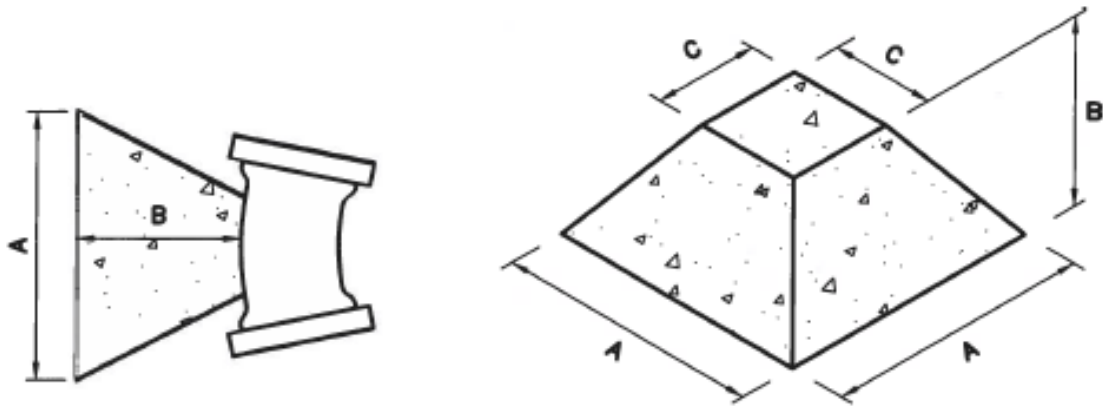

NOTE: USE THE FOLLOWING VALUES FOR 'C'
 PIPE SIZE = C =
 12" & UNDER 1'-6"
 16" TO 24" 2'-0"
 30" TO 36" 3'-0"
 OVER 36" & C WILL BE GIVEN IN EACH INSTANCE

VOL. (yds)	A	B if C=1'-6"	B if C=2'-0"	B if C=3'-0"
1/8	2'-6"	0'-10"	7/8	7/8
1/4	2'-8"	1'-7"	7/8	7/8
1/2	3'-2"	2'-5"	2'-0"	7/8
3/4	4'-0"	2'-6"	2'-2"	7/8
1	4'-4"	3'-0"	2'-7"	2'-0"
1 1/4	4'-10"	3'-1"	2'-9"	2'-2"
1 1/2	5'-3"	3'-3"	2'-11"	2'-4"
1 3/4	5'-7"	3'-5"	3'-1"	2'-6"
2	5'-10"	3'-7"	3'-3"	2'-8"
2 1/4	6'-3"	3'-8"	3'-4"	2'-9"
2 1/2	6'-4"	3'-11"	3'-7"	3'-0"
2 3/4	6'-9"	3'-11"	3'-7"	3'-0"
3	6'-10"	4'-1"	3'-9"	3'-2"
3 1/4	7'-3"	4'-1"	3'-9"	3'-2"
3 1/2	7'-4"	4'-3"	3'-11"	3'-4"
3 3/4	7'-7"	4'-4"	4'-0"	3'-5"
4	7'-11"		4'-0"	3'-5"
4 1/4	8'-1"		4'-0"	3'-6"
4 1/2	8'-4"		4'-0"	3'-6"
4 3/4	8'-6"		4'-1"	3'-7"

VOL. (yds)	A	B if C=1'-6"	B if C=2'-0"	B if C=3'-0"
5	8'-8"		4'-2"	3'-8"
5 1/4	8'-11"		4'-2"	3'-8"
5 1/2	9'-1"		4'-3"	3'-9"
5 3/4	9'-3"		4'-4"	3'-10"
6	9'-4"		4'-5"	3'-11"
6 1/4	9'-6"		4'-6"	4'-0"
6 1/2	9'-8"		4'-6"	4'-0"
6 3/4	9'-11"		4'-6"	4'-0"
7	10'-2"		4'-6"	4'-0"
7 1/4	10'-3"		4'-7"	4'-1"
7 1/2	10'-4"		4'-8"	4'-2"
7 3/4	10'-5"		4'-9"	4'-3"
8	10'-6"		4'-10"	4'-4"
8 1/4	10'-8"		4'-10"	4'-4"
8 1/2	10'-9"		4'-11"	4'-5"
8 3/4	10'-11"		4'-11"	4'-5"
9	11'-1"		4'-11"	4'-5"
9 1/4	11'-2"		5'-0"	4'-6"
9 1/2	11'-4"		5'-0"	4'-6"
9 3/4	11'-6"		5'-0"	4'-6"
10	11'-8"		5'-0"	4'-6"

ALL WATER MAINS GREATER THAN 12 - INCHES IN DIAMETER SHALL HAVE THRUST BLOCK DESIGNED & SHOWN ON THE CONSTRUCTION DOCUMENTS.

SEE VOLUMES ABOVE FOR A, B & C DIM.

FITTING	4"	6"	8"	12"
TEE	1/8 yd.	1/2 yd.	3/4 yd.	2 yd.
90° BEND	1/8 yd.	1/4 yd.	1 1/4 yd.	3 yd.
45° BEND	1/8 yd.	1/2 yd.	3/4 yd.	1 1/2 yd.
22-1/2° BEND	1/8 yd.	1/8 yd.	1/4 yd.	3/4 yd.
11-1/4° BEND	1/8 yd.	1/8 yd.	1/8 yd.	1/4 yd.



DONALA WATER & SANITATION DISTRICT

THRUST BLOCK DATA

DRAWN: GSM	REVISED:
DATE: JAN. 04	REVISED:
SCALE: NONE	REVISED:

W-13

I:\DONALAI\STD\SPCS\W\std\13.dwg, Layout1_4/26/2018 5:32:40 PM, sc, Xerox Altheink CR035, 1:1

CONCRETE THRUST BLOCKS

WATER MAIN AND TAP SIZE COMBINATIONS WHICH REQUIRE A CONCRETE THRUST REACTION BLOCK BEHIND THE MAIN AT THE TAPPING SLEEVE OR SADDLE.

ALL WATER MAINS

 INDICATES CONCRETE THRUST BLOCK REQUIRED

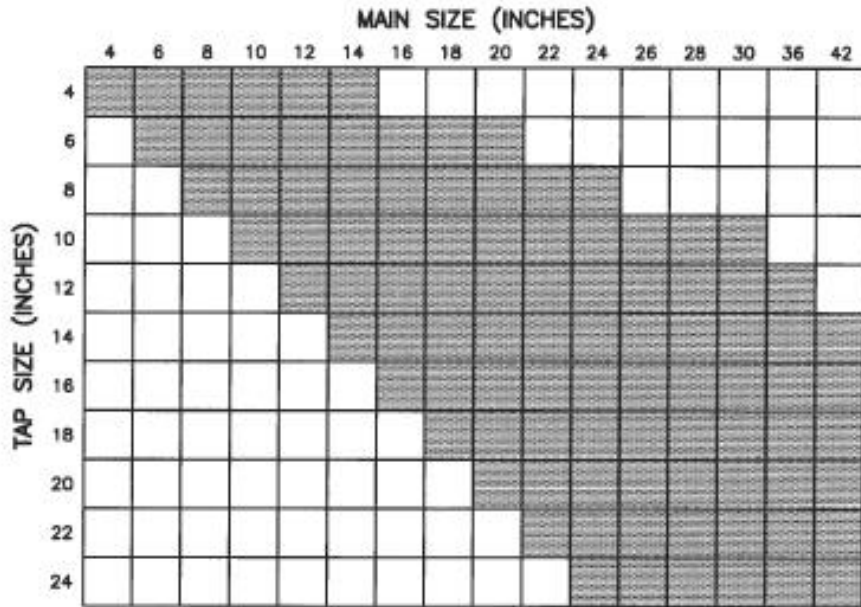

ANY THRUST REACTION BLOCK REQUIREMENTS FOR WATER MAIN AND TAP SIZE COMBINATIONS OTHER THAN THOSE SHOWN ABOVE WILL REQUIRE SPECIAL DESIGN APPROVAL BY THE DONALA WATER & SANITATION DISTRICT.

G:\DONALAWATER\DESIGN\WaterMain\Draw-14.dwg, Layout1, 4/27/2018 7:28:41 AM, sc, Xerox Alipink C8035, 1:1



DONALA WATER & SANITATION DISTRICT

THRUST BLOCKS REQUIRED FOR TAPS

DRAWN: GSM	REVISED:
DATE: JAN. 04	REVISED:
SCALE: NONE	REVISED:

W-14

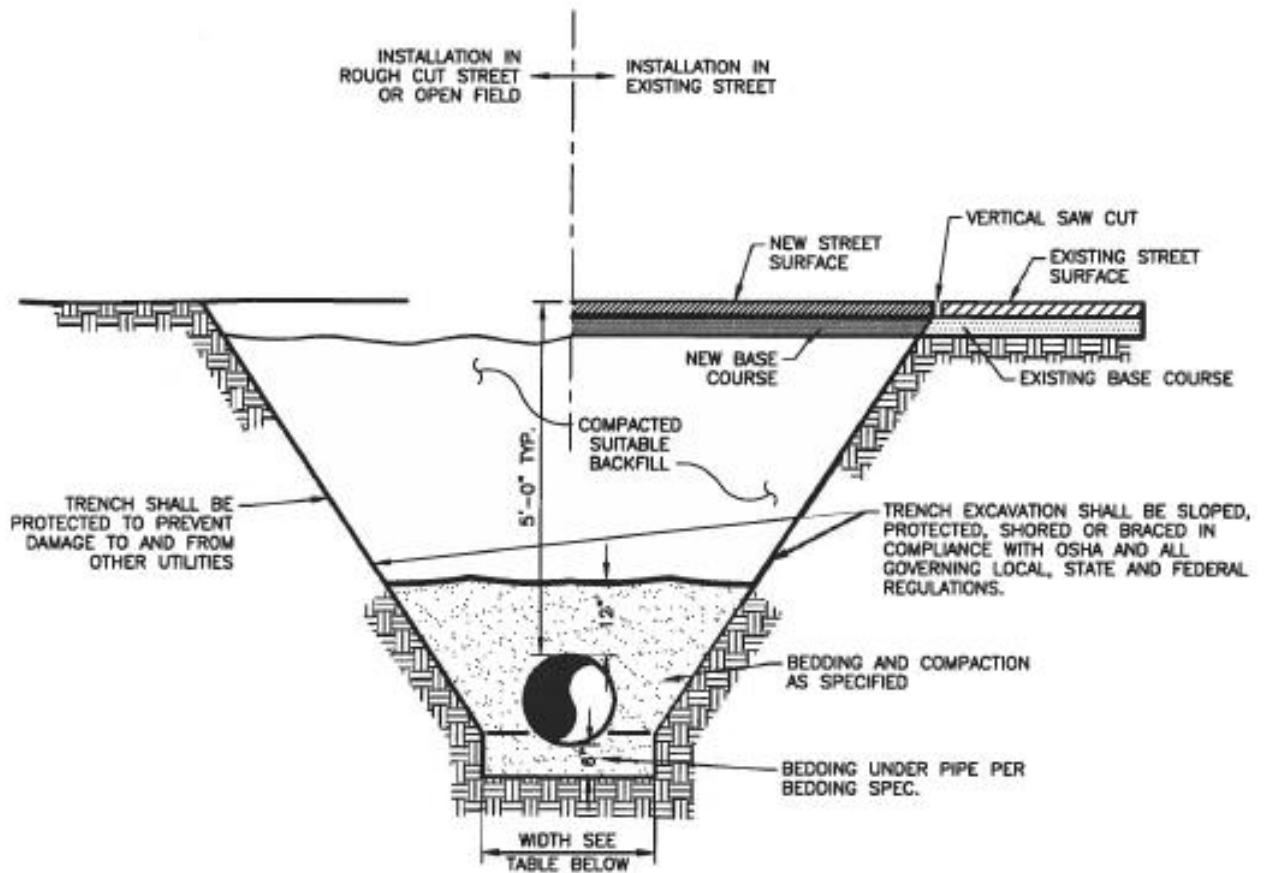

BOTTOM OF TRENCH WIDTH		
PIPE DIAMETER	MINIMUM WIDTH	MAXIMUM WIDTH
4"	1'-5"	3'-9"
6"	1'-7"	3'-11"
8"	1'-9"	4'-1"
12"	2'-1"	4'-5"
16"	2'-6"	4'-9"
20"	2'-10"	5'-2"
24"	3'-2"	5'-8"

AN OVER EXCAVATED TRENCH SHALL BE REFILLED AND THOROUGHLY COMPACTED UNDER THE DIRECTION OF THE DISTRICT.

UNDER NO CIRCUMSTANCES WILL PIPE BE LAID IN A PROPOSED FILL AREA PRIOR TO IT BEING COMPLETELY FILLED. THE FILL WILL BE PLACED FIRST TO PROPOSED GRADE AND COMPACTED AS REQUIRED. A TRENCH THEN WILL BE EXCAVATED AND THE PIPE INSTALLED IN THE USUAL MANNER.



DONALA WATER & SANITATION DISTRICT

TYPICAL TRENCH CROSS SECTION

DRAWN: GSM	REVISED:
DATE: JAN. 04	REVISED:
SCALE: NONE	REVISED:

W-15

MAXIMUM DEFLECTION PER SLIP JOINT OF D.I.P.

PIPE DIAMETER			MFRS. DEFL.	DESIGN DEFLECTION (80% MAX.)			APPROX. RADIUS FOR DEFLECTING CURVES WITHOUT BENDS	
I.D.	O.D.(IN.)	O.D.(FT.)		MAX. DEFL. DIST.		20'L	18'L	
				(1)	(2)			
4"	4.80"	.400'	5'00"00"	4'00"00"	16"	15"	286'	258'
6"	6.90"	.575'	5'00"00"	4'00"00"	16"	15"	286'	258'
8"	9.05"	.754'	5'00"00"	4'00"00"	16"	15"	286'	258'
10"	11.10"	.925'	5'00"00"	4'00"00"	16"	15"	286'	258'
12"	13.20"	1.100'	5'00"00"	4'00"00"	16"	15"	286'	258'
14"	15.30"	1.275'	3'00"00"	2'24"00"	10"	9"	477'	430'
16"	17.40"	1.450'	3'00"00"	2'24"00"	10"	9"	477'	430'
18"	19.50"	1.625'	3'00"00"	2'24"00"	10"	9"	477'	430'
20"	21.60"	1.800'	3'00"00"	2'24"00"	10"	9"	477'	430'
24"	25.80"	2.150'	3'00"00"	2'24"00"	10"	9"	477'	430'
30"	32.00"	2.666'	2'30"00"	2'00"00"	8"	7"	573'	516'
36"	38.30"	3.192'	2'00"00"	1'36"00"	6"	6"	716'	645'
42"	44.50"	3.708'	2'00"00"	1'36"00"	6"	6"	716'	645'

(1) 20'L = NORMAL 20-FOOT JOINT LAYING LENGTH
(2) 18'L = NORMAL 18-FOOT JOINT LAYING LENGTH

G:\DONALAI\STDSPEC\Waters\Draw-16.dwg, Layout1, 4/27/2016 7:13:25 AM, sc, Xerox AltaLink C8035, 1:1



**DONALA WATER &
SANITATION DISTRICT**

MAXIMUM PIPELINE DEFLECTION DATA

DRAWN: GSM	REVISED:
DATE: JAN. 04	REVISED:
SCALE: NONE	REVISED:

W-16

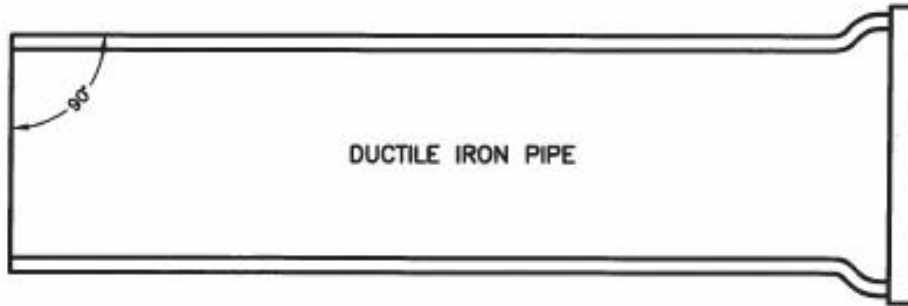

MECHANICAL JOINT CONNECTION

PIPE MUST BE CUT AT RIGHT ANGLES TO LONGITUDINAL CENTERLINE IN ALL CASES.

PIPE ENDS SHALL BE FREE OF BURRS.

MORTAR LINING SHALL BE FLUSH WITH PIPE END.

GOUGES CUT IN PIPE ENDS SHALL NOT BE ALLOWED.

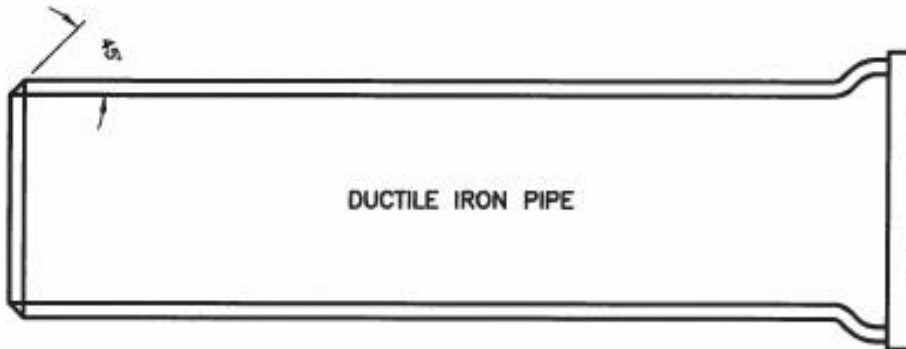

SLIP JOINT CONNECTION

PIPE CUT IN STRAIGHT LINE AND BEVELED AT 45° ANGLE ON END.

GENERAL NOTES:

1. ALL PIPE CUTTING EQUIPMENT AND PIPE CUTS MUST BE APPROVED BY THE DONALA WATER AND SANITATION DISTRICT INSPECTOR.
2. ALL PIPE ENDS TO BE USED IN INSTALLATION SHALL BE DRESSED SMOOTH TO THE SATISFACTION OF THE INSPECTOR PRIOR TO INSTALLATION.
3. AT THE REQUEST OF THE CONTRACTOR MAKING THE INSTALLATION, THE DISTRICT WILL MAKE PIPE CUTS, PROVIDING THE CURRENT FEE PER CUT IS PAID AND 24-HOUR NOTICE IS GIVEN (THE CURRENT FEE IS SUBJECT TO CHANGE.)
4. ALL DIP DELIVERED TO JOB SITE MUST BE NEW MATERIAL.



DONALA WATER & SANITATION DISTRICT

PIPE CUTTING

DRAWN: GSM	REVISED:
DATE: JAN. 04	REVISED:
SCALE: NONE	REVISED:

W-17

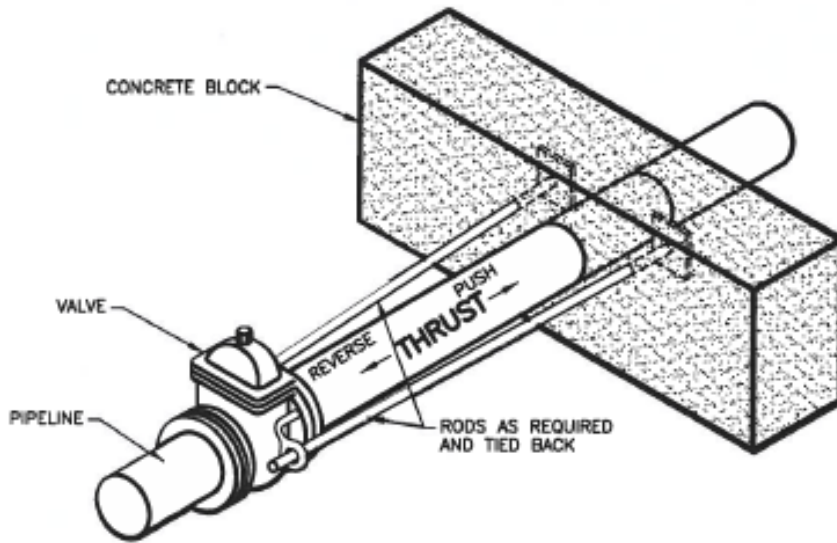

TYPICAL VALVE ANCHOR

'A' MEASUREMENTS:

12" & UNDER = 2'-0"
 OVER 12" = 3'-0"

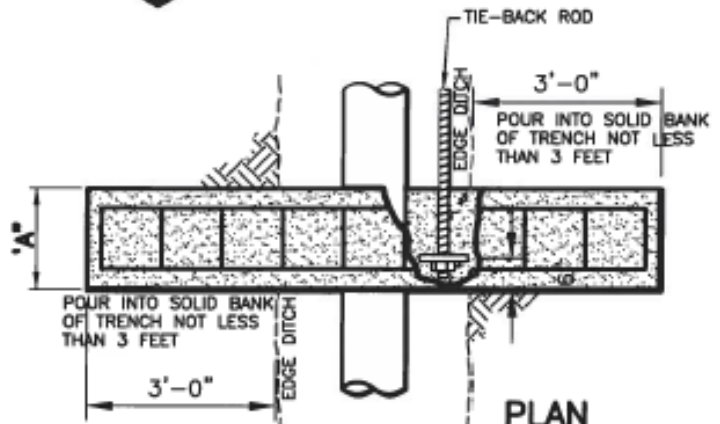

CONCRETE BLOCK W/NO. 6 REBAR @ 12" O.C.

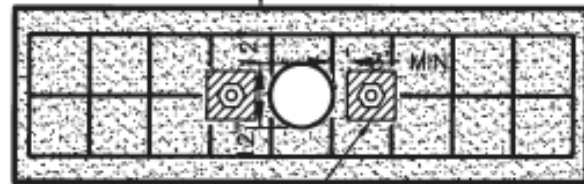

ELEVATION
 (DEAD-END OR REVERSE ANCHOR)

USE W6x20 BEAM FOR 6" AND 8" PIPING(REINFORCE W/6"x6"x1/4" PL WELDED TO BEAM AT HOLE LOCATIONS)
 USE CROSS I-BEAMS FOR 12" DIA. AND ABOVE. SEE DWG-23 AND DWG-24.

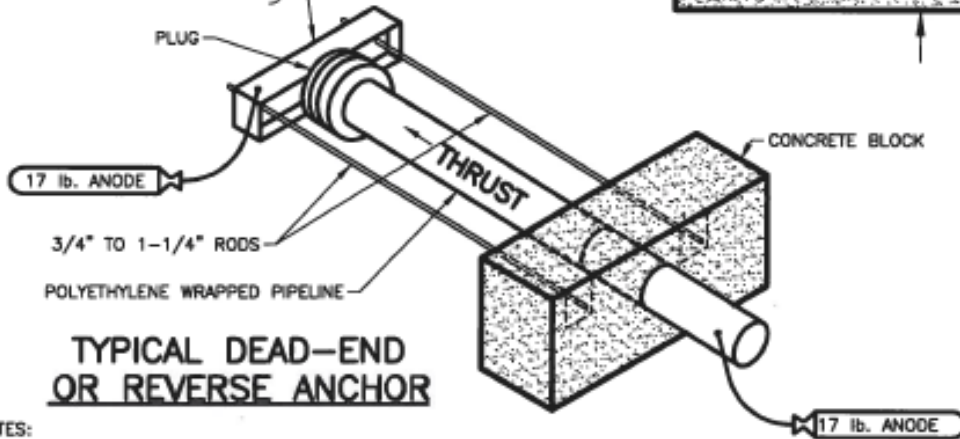

TYPICAL DEAD-END OR REVERSE ANCHOR

NOTES:

1. MAX. ROD LENGTH = 12'
 MIN. ROD LENGTH = 4'
2. COAT RODS AND BEAM WITH COAL TAR PROTECTION SEE CHAPTER 4 AND 36.



DONALA WATER & SANITATION DISTRICT

REVERSE ANCHOR DETAIL

DRAWN: GSM	REVISED:
DATE: JAN. 04	REVISED:
SCALE: NONE	REVISED:

W-18A

S:\DONALASITDSECS\Water\Draw-18A.dwg_18A_4/27/2018 7:13:45 AM sc Xerox Altalink C8035 1:1

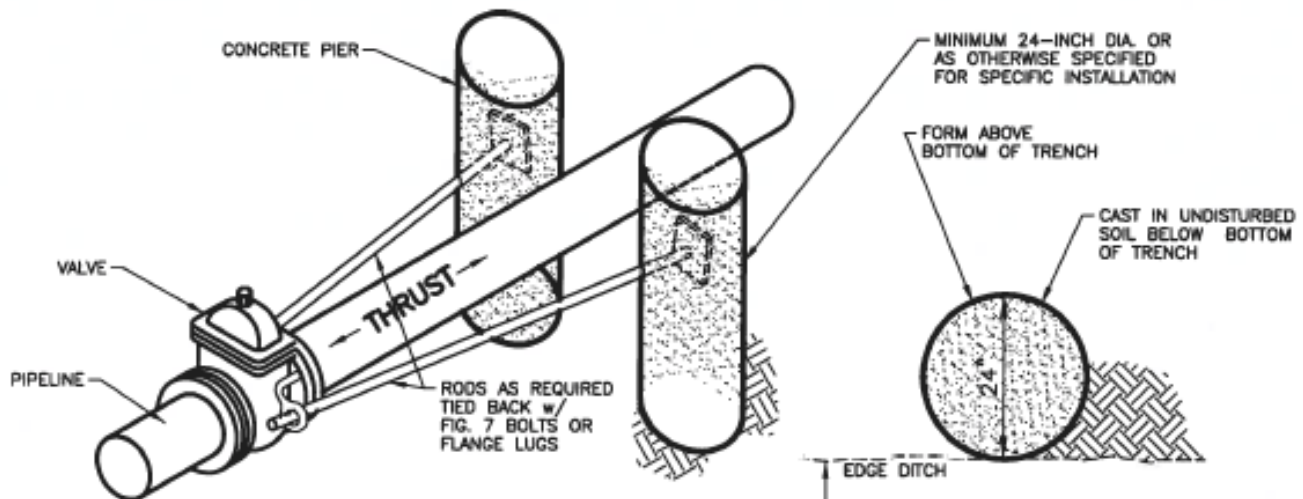

TYPICAL VALVE ANCHOR

NOTE: NARROW DITCH REQ'D AT ANCHOR LOCATION

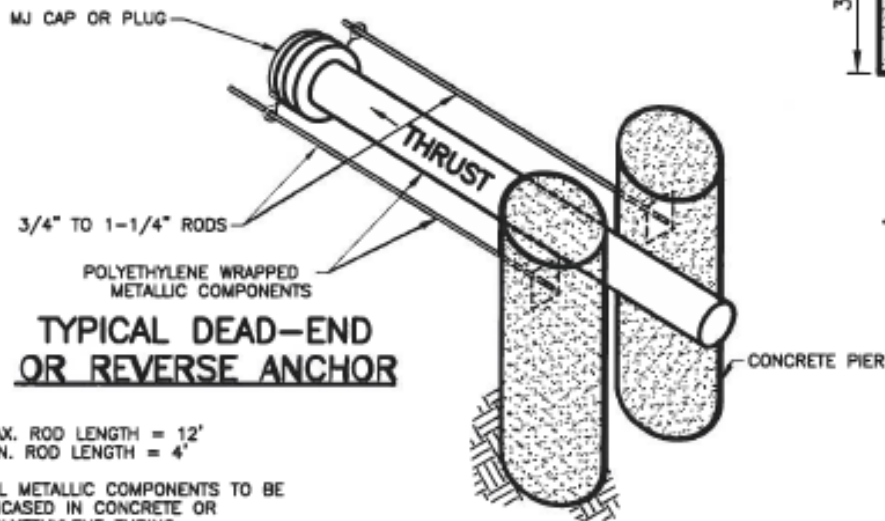
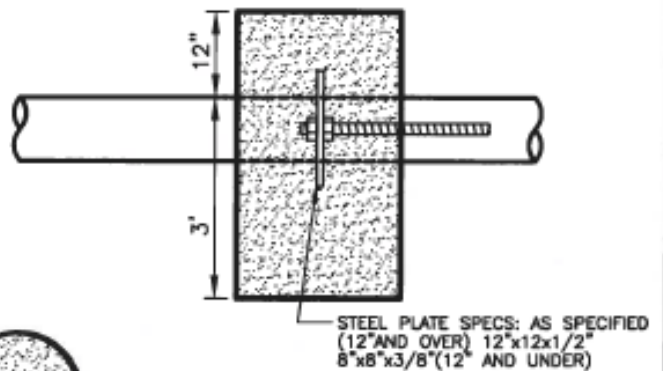
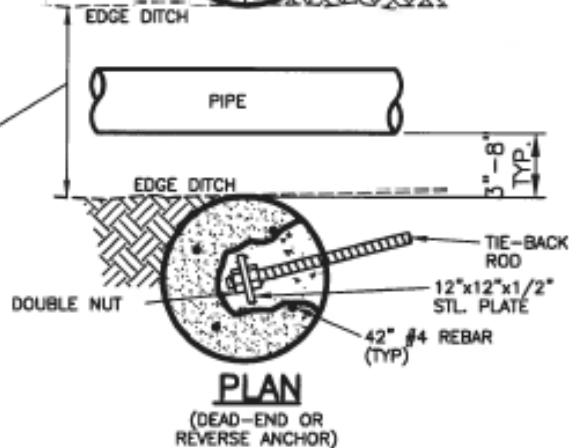

TYPICAL DEAD-END OR REVERSE ANCHOR

- NOTES:
1. MAX. ROD LENGTH = 12'
MIN. ROD LENGTH = 4'
 2. ALL METALLIC COMPONENTS TO BE ENCASED IN CONCRETE OR POLYETHYLENE TUBING.

REVERSE ANCHOR DETAIL

DRAWN: GSM	REVISED:
DATE: JAN. 04	REVISED:
SCALE: NONE	REVISED:

W-18B



DONALA WATER & SANITATION DISTRICT

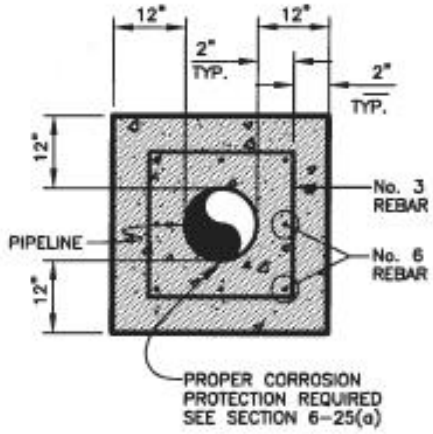
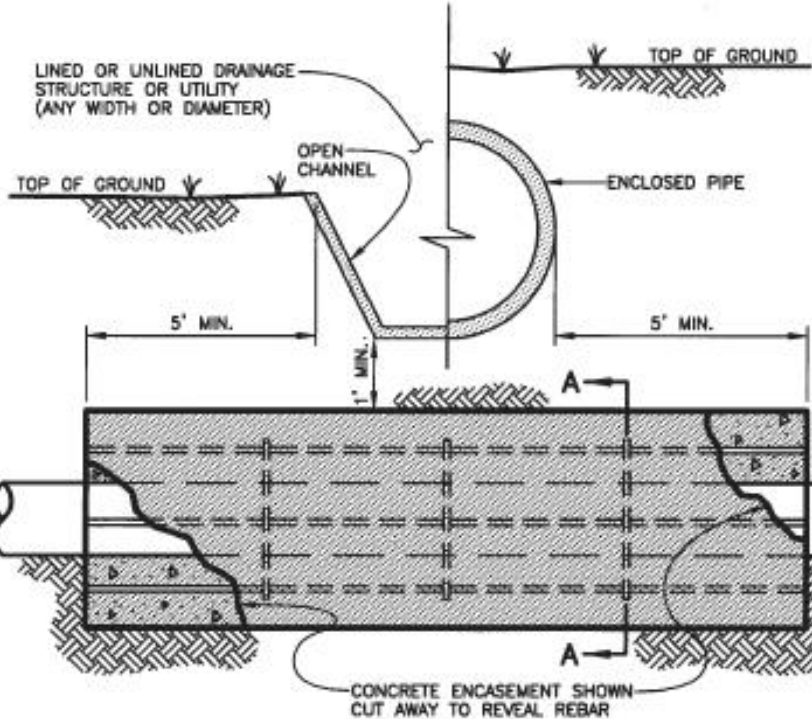
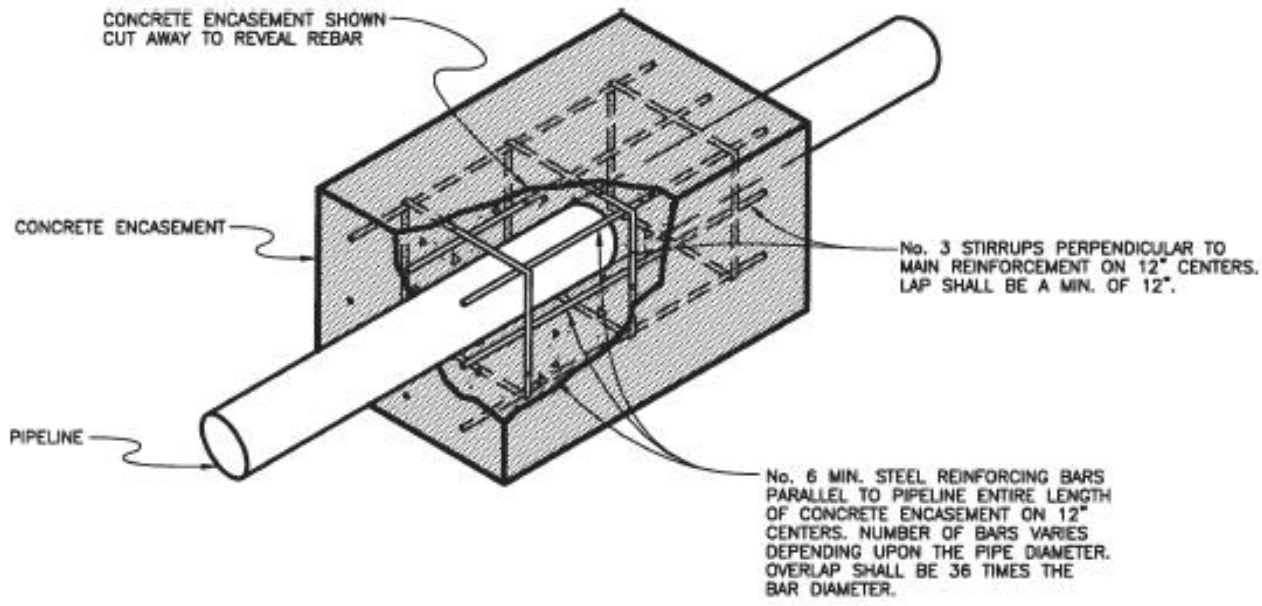

G:\DONALAVISTOSPECS\Water\Doc-19.dwg, Layout11, 4/27/2018 7:14:04 AM, rc, Xerox, A:link C8035, 1:1



CONCRETE PIPE ENCASEMENT DETAIL

DRAWN: GSM	REVISED:	W-19
DATE: JAN. 04	REVISED:	
SCALE: NONE	REVISED:	

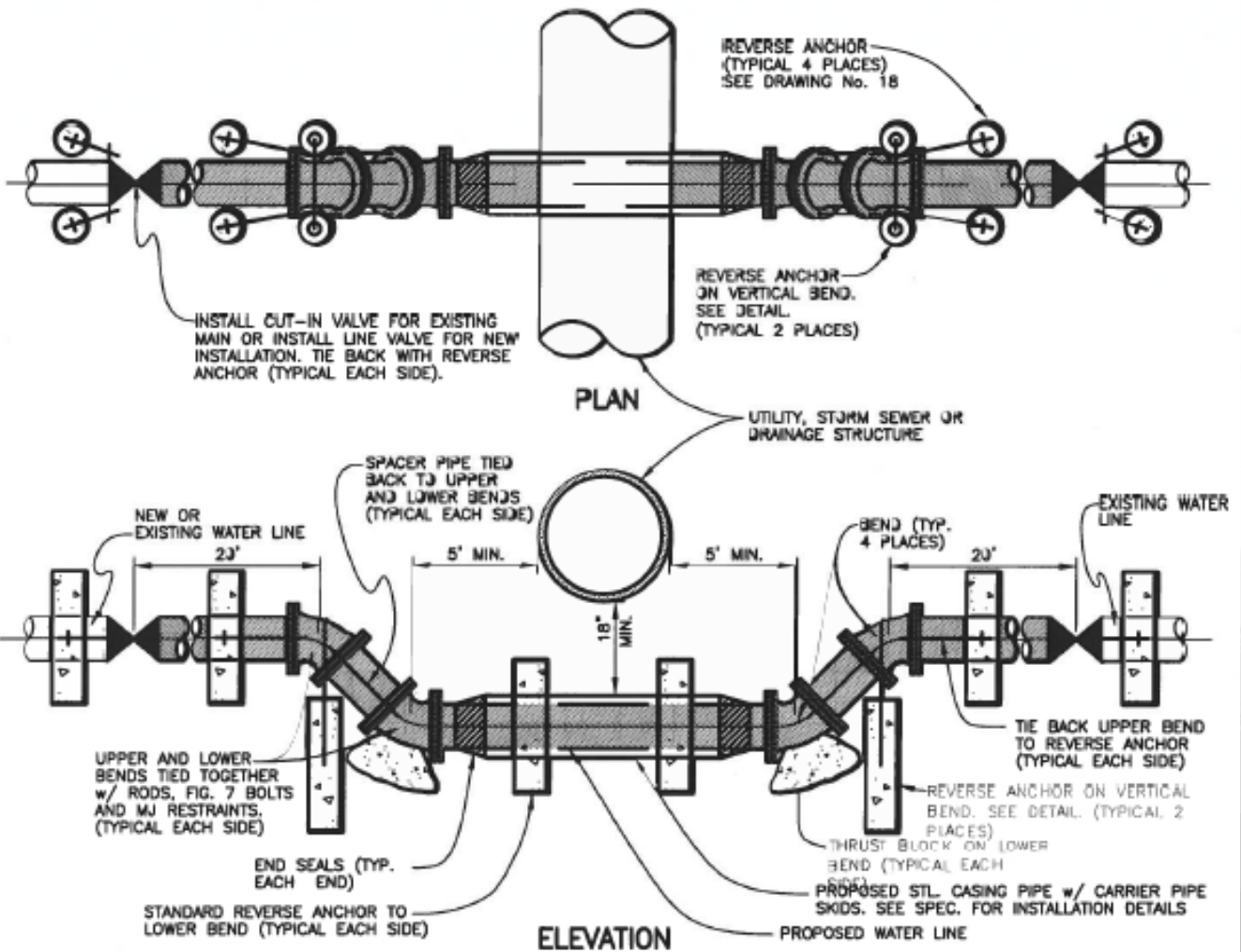

GENERAL NOTES:

1. NO PVC PIPE ALLOWED IN LOWERINGS.
2. LOWERINGS TO BE PROTECTED FROM CORROSION AS DIRECTED BY INSPECTOR.
3. A CASING PIPE IS NOT REQUIRED WHEN THE DRAINAGE STRUCTURE IS 30 INCHES OR LESS OUTSIDE DIAMETER.
4. FURNISH AND INSTALL STEEL CASING PIPE WITH CARRIER PIPE SKIDS (PSI) AND END SEALS WHERE THE DRAINAGE STRUCTURE IS MORE THAN 30 INCHES OUTSIDE DIAMETER. MAINTAIN 18 INCHES CLEAR BETWEEN STRUCTURE AND CASING PIPE.
5. FURNISH AND INSTALL ONE-17LB. MAGNESIUM ANODE PER 20-FOOT OR LESS OF CASING PIPE. ATTACH TO CASING PIPE NEAR END SEAL.
6. FURNISH AND INSTALL JOINT BONDING, POLYETHYLENE TUBING/ENCASEMENT AND 17LB. MAGNESIUM ANODE ON DIP IN LOWERING. PROVIDE ONE ANODE PER 20-FOOT OR LESS OF DIP INSTALLED. REFER TO STANDARD SPECIFICATIONS.
7. EBBA IRON 1600 (OR EQUAL) MECHANICAL JOINT RESTRAINT REQUIRED ON ALL JOINTS INSIDE CASING PIPE.

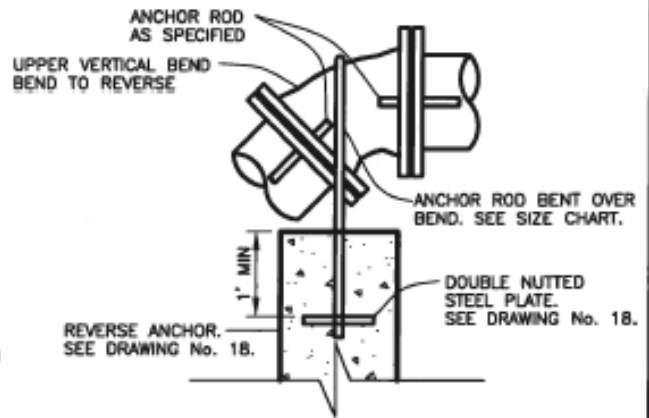

ANCHOR ROD SIZING CHART FOR REVERSE ANCHOR ON VERTICAL BEND

PIPE DIA. (IN.)	MIN. ROD DIA. (IN.)
4	3/8
6	1/2
8	5/8
10	SPECIAL DESIGN REQ'D

DETAIL



DONALA WATER & SANITATION DISTRICT

WATER LINE LOWERING DETAIL

DRAWN: GSM	REVISED:
DATE: JAN. 04	REVISED:
SCALE: NONE	REVISED:

W-20

G:\DONALAI\STD\SPCS\Water\Draw-20.dwg, Layout1, 4/27/2018 7:28:40 AM, sc, Xref: A:\link C8035, 1:1

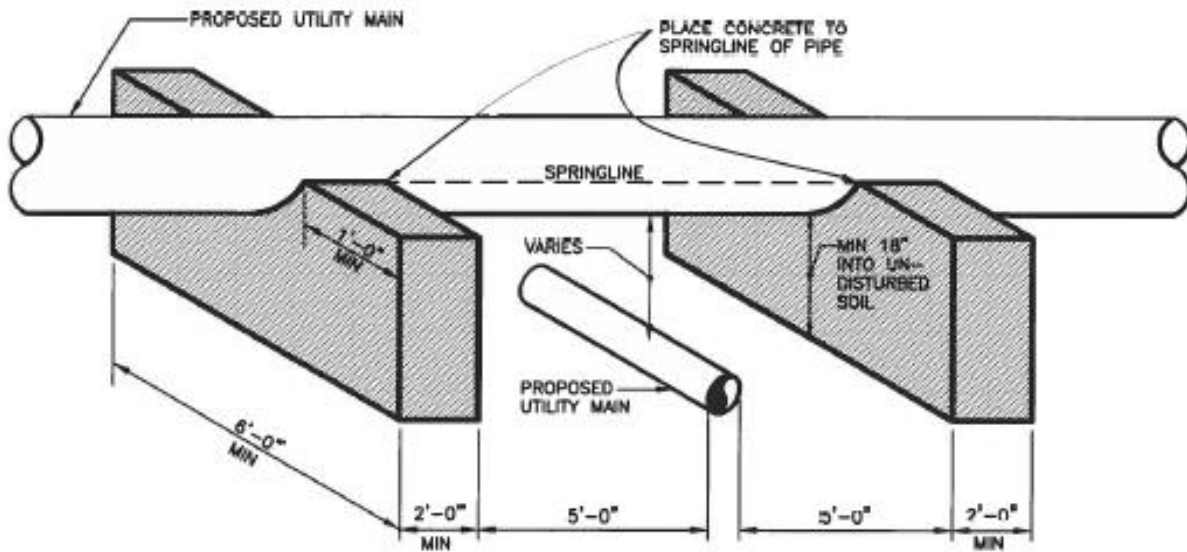

NOTES :

1. CONCRETE BLOCKS TO BE REINFORCED WITH No. 6 REBAR SET ON 12" CENTERS.
2. NO JOINTS OF UTILITY MAIN SHALL BE ALLOWED BETWEEN CONCRETE BRIDGING BLOCKS.

S:\DONALAVISTDSPEC\W\std\Draw-21.dwg, Layout1, 4/27/2018, 10:13:54 AM, sp, Xrefsv, Altlink, C8035, 1:1



DONALA WATER & SANITATION DISTRICT

PIPE BRIDGING DETAIL

DRAWN: GSM	REVISED:
DATE: JAN. 04	REVISED:
SCALE: NONE	REVISED:

W-21

G:\DONAL WATER & SANITATION DISTRICT\DWG-22.dwg, Layout1_4/27/2018 8:45:58 AM, sp, Xerox AltaLink C8035, 14

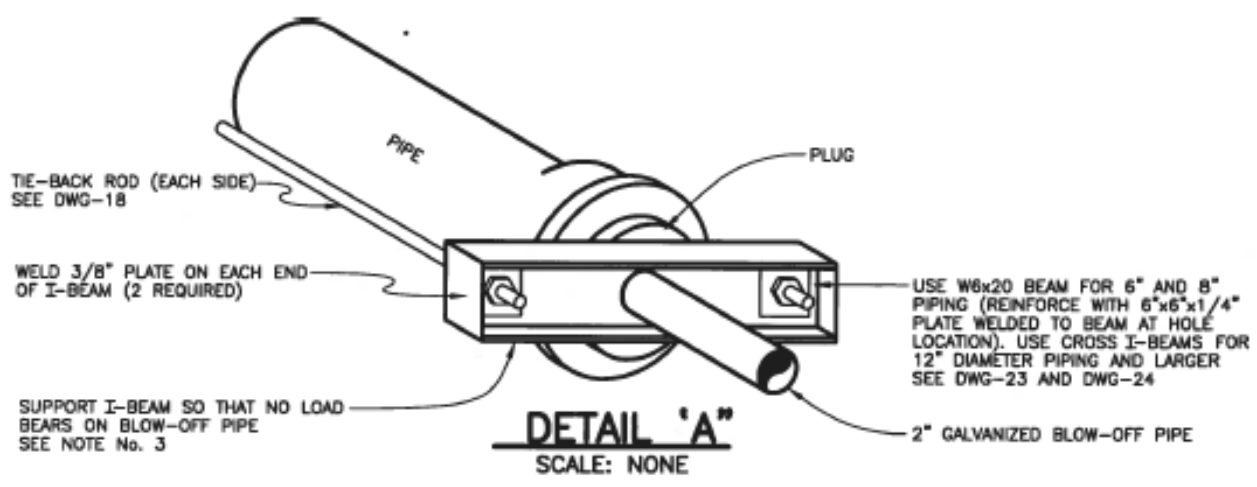
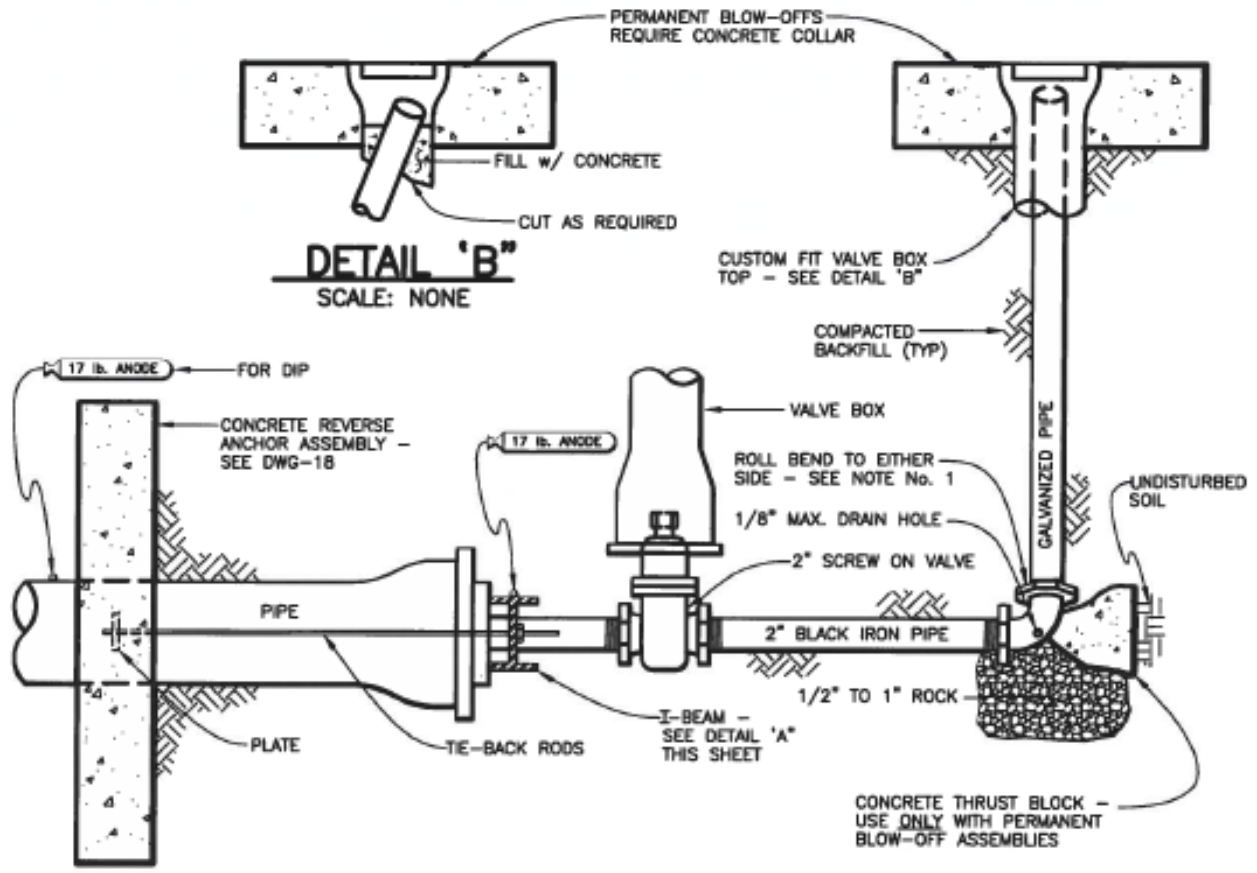

NOTES:

1. IF APPROPRIATE LOCATION FOR DISCHARGED WATER CANNOT BE REACHED BY ROLLING THE BEND, ADDITIONAL BENDS MAY BE REQUIRED BY THE INSPECTOR.
2. COAT TIE RODS, BEAM AND BLACK IRON PIPE WITH EPOXY POLYAMIDE COATING, 10 MILS. MIN.
3. ENTIRE BLOW OFF ASSEMBLY MUST BE FULLY SUPPORTED, CONCRETE STEPPING STONES MAY BE REQUIRED.
4. PIPE DOPE APPROVED FOR USE IN POTABLE WATER SYSTEMS MUST BE USED ON ALL THREADED JOINTS.



TEMPORARY AND PERMANENT BLOW OFF ASSEMBLIES FOR 6" AND 8" MAINS		
DRAWN: GSM	REVISED:	
DATE: JAN. 04	REVISED:	
SCALE: NONE	REVISED:	
		W-22

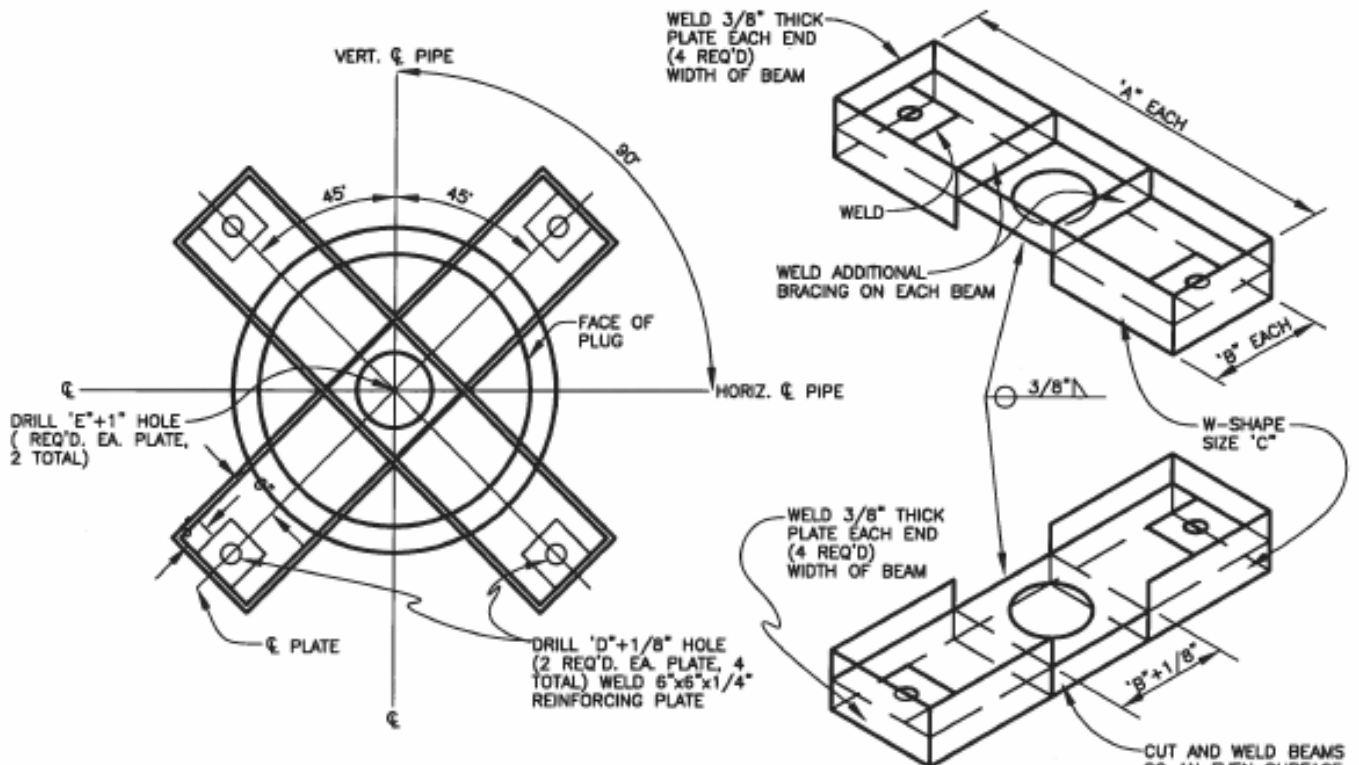

REFER TO DWG-24 FOR ALL DIMENSIONS AND SIZES

'E' = SIZE OF BLOW-OFF ASSEMBLY
(WHERE 'E' = 2", USE STANDARD BLOW-OFF ASSEMBLY DWG-22)

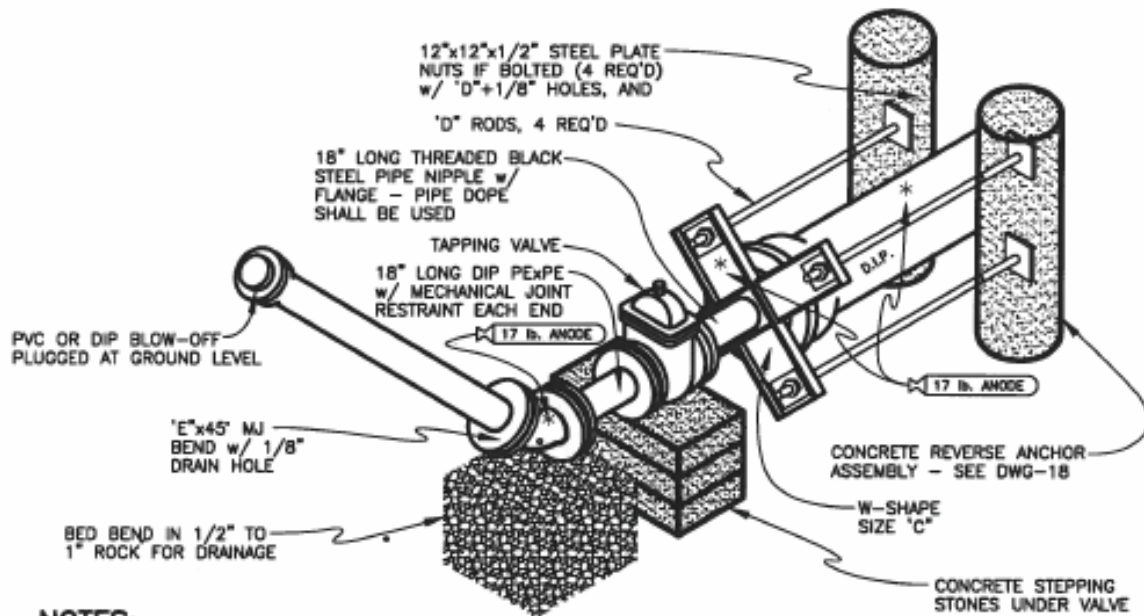

NOTES:

1. PIPE DOPE APPROVED FOR USE IN POTABLE WATER SYSTEMS MUST BE USED ON ALL THREADED JOINTS.
2. ENTIRE BLOW OFF ASSEMBLY MUST BE FULLY SUPPORTED SO NO LOAD BEARS ON BLOW-OFF PIPING.
3. IF APPROPRIATE LOCATION FOR DISCHARGED WATER CANNOT BE REACHED BY ROLLING THE BEND, ADDITIONAL BENDS MAY BE REQUIRED.
4. COAT TIE RODS, BEAMS AND BLACK IRON PIPE WITH EPOXY POLYAMIDE COATING, 10 MILS. MIN.



DONALA WATER & SANITATION DISTRICT

TEMPORARY AND PERMANENT BLOW OFF ASSEMBLIES FOR 12" AND LARGER

DRAWN: GSM	REVISED:
DATE: JAN. 04	REVISED:
SCALE: NONE	REVISED:

W-23

G:\DONALASISTDSECS\Water\Draw-23.dwg, Layout1, 4/27/2018 8:46:19 AM, sc, Xerox Albalink C5035, 1:1

BLOW OFF ASSEMBLY SIZING

MAIN PIPE DIA. (IN)	STATIC PRESSURE RANGE (PSI)	DIMENSIONS FROM DWG-23				
		'A" (IN)	'B" (IN)	'C" (W-SHAPE)	'D" ROD SIZE (IN)	'E" BLOW-OFF PIPE SIZE (IN)
12	<100	36	10	W10x15	5/8	2
	101-150	36	10 1/4	W10x19	3/4	2
	151-200	36	10 1/8	W10x22	7/8	2
	201-250	36	10 1/8	W10x22	1	2
16	<100	40	12 1/4	W12x26	7/8	4
	101-150	40	12 1/4	W12x26	1	4
	151-200	40	12 1/4	W12x26	1 1/8	4
	201-250	40	12 1/2	W12x35	1 1/4	4
20	<100	44	12 1/4	W12x26	1	4
	101-150	44	12 1/2	W12x35	1 1/4	4
	151-200	44	12	W12x40	1 3/8	4
	201-250	44	12	W12x45	1 1/2	4
24	<100	48	12 1/2	W12x35	1 1/4	6
	101-150	48	12	W12x40	1 1/2	6
	151-200	48	12	W12x53	1 1/4 *	6
	201-250	48	12	W12x53	1 1/8 *	6
30	<100	54	12 1/4	W12x50	1 1/8 *	6
	101-150	54	12 1/4	W12x58	1 3/8 *	6
	151-200	54	12 1/8	W12x65	1 1/2 *	6
	201-250	54	12 1/4	W12x72	1 5/8 *	6
36	<100	60	12 1/4	W12x58	1 1/4 *	8
	101-150	60	12 1/4	W12x72	1 1/2 *	8
	151-200	60	12 3/4	W12x96	1 3/4 *	8

NOTES:

1. ALL W-SHAPES SHALL BE FABRICATED FROM A36 STEEL.
2. ALL RODS SHALL BE MINIMUM GRADE A307 EXCEPT WHERE NOTED AS *. THESE SHALL BE MINIMUM STRENGTH EQUAL TO ASTM A325 RODS (SEE SECTION 4.06).
3. A 50% SURGE FACTOR HAS BEEN INCLUDED IN THE DESIGN.
4. FOR SIZES AND PRESSURES GREATER THAN THOSE SHOWN, SPECIAL DESIGN IS REQUIRED, APPROVED BY THE DISTRICT.



DONALA WATER & SANITATION DISTRICT

**BLOW OFF ASSEMBLY DIMENSION DATA
FOR MAINS 12" AND LARGER**

DRAWN: GSM	REVISED:
DATE: JAN. 04	REVISED:
SCALE: NONE	REVISED:

W-24

G:\MUNALAN\STDSPES\Water\W-24.dwg, Layout1, 4/27/2018, 8:46:45 AM, sc, Xerox, A:helink C5035, 1:1

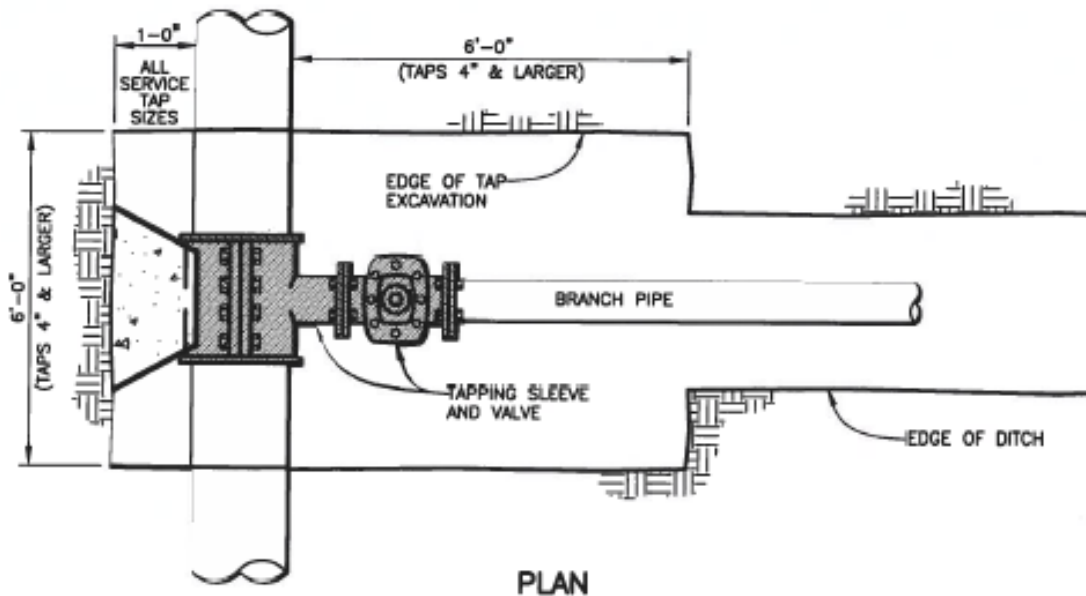

PLAN

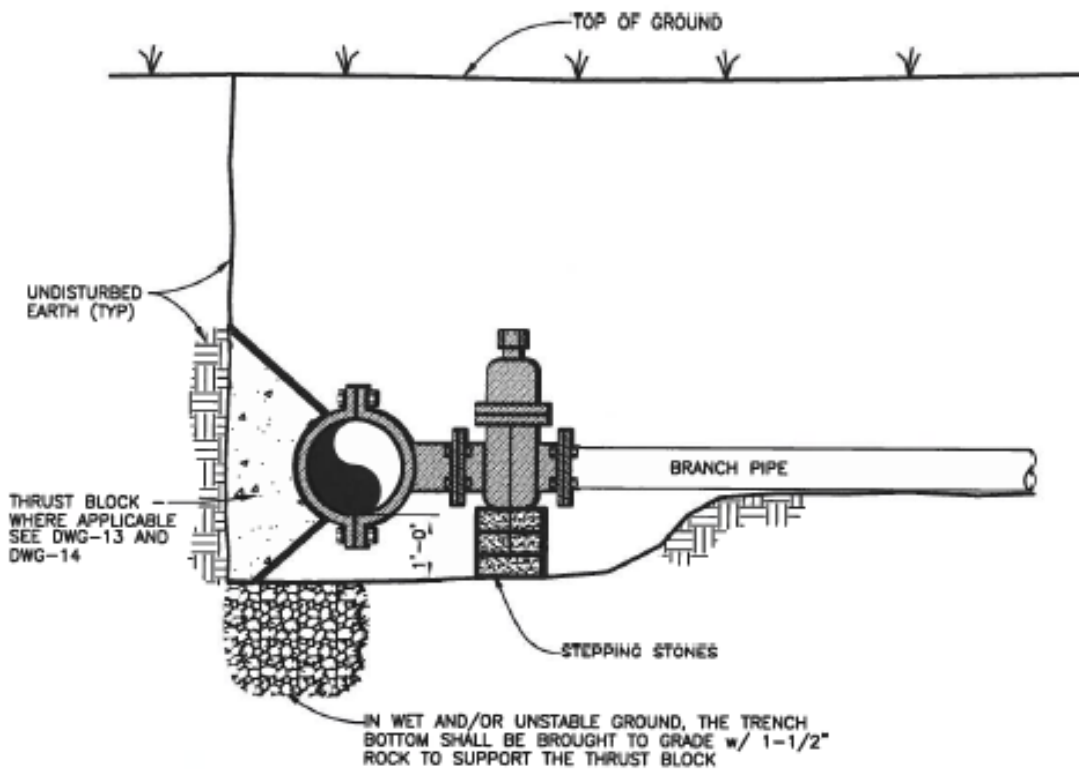

ELEVATION

G:\DONALISTD\SPECS\Water\Drawings\Layout1.dwg, 5/27/2018 8:47:11 AM, sc, Xerox Allink C8035, 1:1



DONALA WATER & SANITATION DISTRICT

PIPE TAPPING DETAIL

DRAWN: GSM	REVISED:
DATE: JAN. 04	REVISED:
SCALE: NONE	REVISED:

W-25

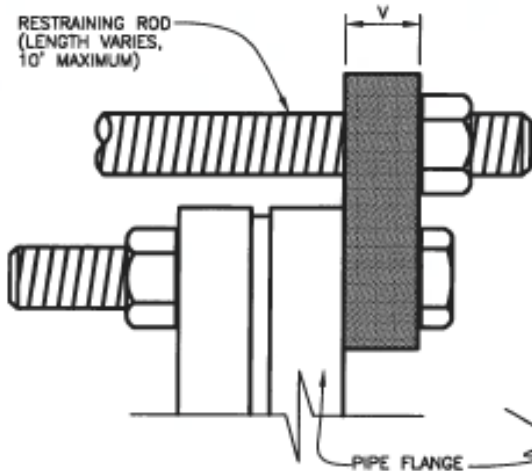

SIDE

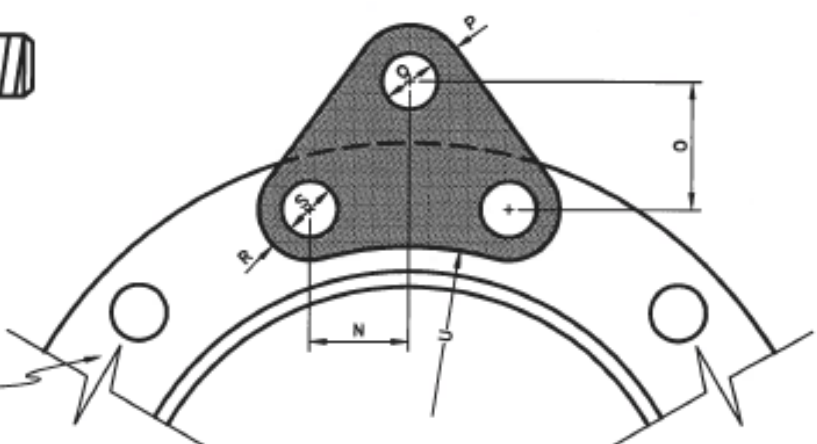

FACE

PIPE DIA. (IN)	PRESS. CLASS (PSI)	'N' (IN)	'O' (IN)	H.S. ROD			M.S. ROD			'R' (IN)	'S' (IN)	'U' (IN)	'V' (IN)	NO. REQ'D (EA)
				'P' (IN)	'Q' (IN)	ROD DIA. (IN)	'P' (IN)	'Q' (IN)	ROD DIA. (IN)					
6	150	1 ¹⁵ / ₁₆	2 ¼	1	7/8	¾	1	7/8	¾	7/8	7/8	3¾	¾	2
	300	1¾	2¾	1	1	7/8	1	1	7/8	7/8	7/8	4 ⁷ / ₁₆	1	
8	150	2 ¼	2¾	1	7/8	¾	1	7/8	¾	1	7/8	4 ⁷ / ₈	¾	2
	300	1 ¹¹ / ₁₆	2 ⁷ / ₈	1	1	7/8	1	1	7/8	1	1	5 ½	1	
12	150	2 ³ / ₁₆	2¾	1¼	1½	1	1¼	1½	1	1½	1	7 ¼	7/8	2
	300	1¾	3¾	1¾	1¼	1½	1¾	1¾	1¼	1¼	1½	7 ⁵ / ₈	1¼	
16	150	2 ¹ / ₁₆	2¾	1½	1¾	1¼	1½	1¾	1¼	1¼	1½	9 ³ / ₈	1½	3
	300	1¾	4 ¼	1½	1½	1¾	1½	1½	1¾	1½	1¾	9 ⁷ / ₈	1½	

NOTES

1. M.S. MEANS MILD STEEL ROD, ASTM STANDARD DESIGNATION A-36. NUTS SHALL BE ASTM STANDARD DESIGNATION A-307 GRADE A OR B HEXAGON HEAVY SERIES.
2. H.S. MEANS HIGH STRENGTH STEEL ROD, ASTM STANDARD DESIGNATION A-193 GRADE B-7. NUTS SHALL BE ASTM STANDARD DESIGNATION A-193 GRADE 2-H.



DONALA WATER & SANITATION DISTRICT

FLANGE-LUG DETAIL

DRAWN: GSM	REVISED:
DATE: JAN. 04	REVISED:
SCALE: NONE	REVISED:

W-26

G:\DONALA\STD\SPCS\WaterDwg-28.dwg, Layout1, 4/27/2018 8:47:33 AM, sc, Xerox Altalink C8035, 1:1

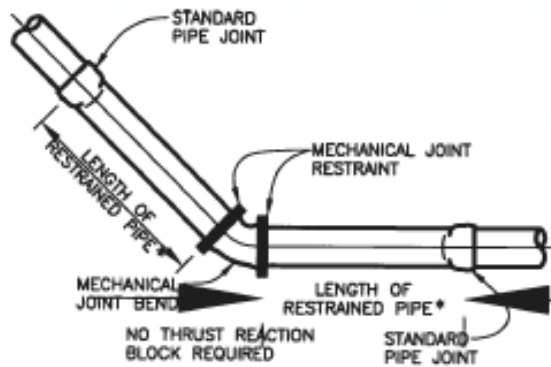

INSTALLATION FOR BENDS

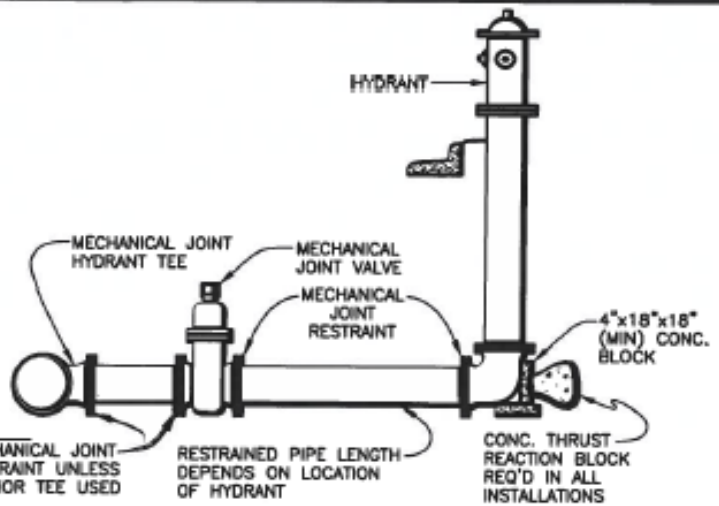

INSTALLATION FOR FIRE HYDRANT

NOTE: ALL JOINTS BETWEEN HYDRANT AND TEE MUST BE RESTRAINED.

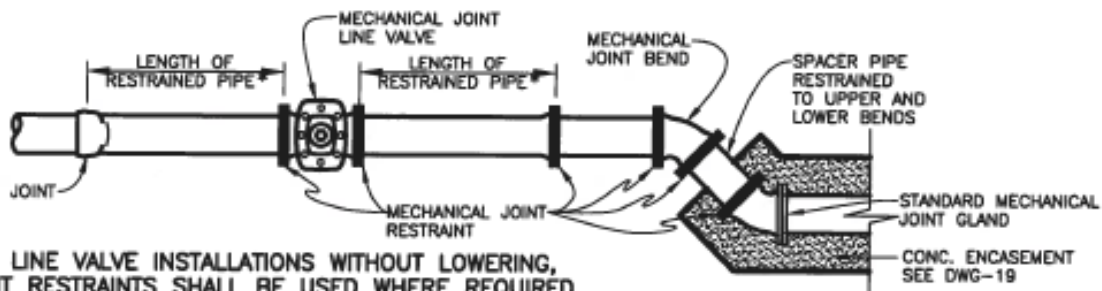

NOTE: FOR LINE VALVE INSTALLATIONS WITHOUT LOWERING, JOINT RESTRAINTS SHALL BE USED WHERE REQUIRED BY THE WATER DEPARTMENT.

INSTALLATION FOR LINE VALVE AND LOWERING

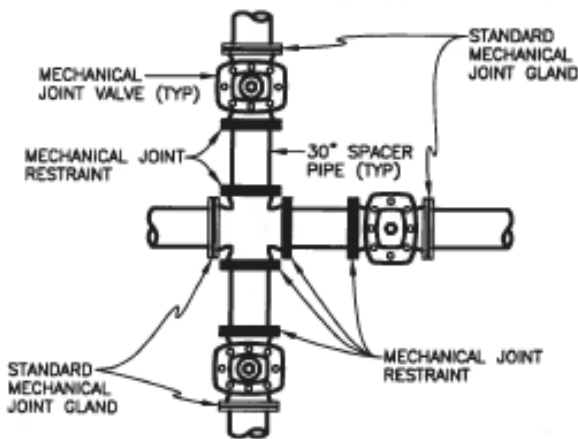

CROSS INSTALLATION

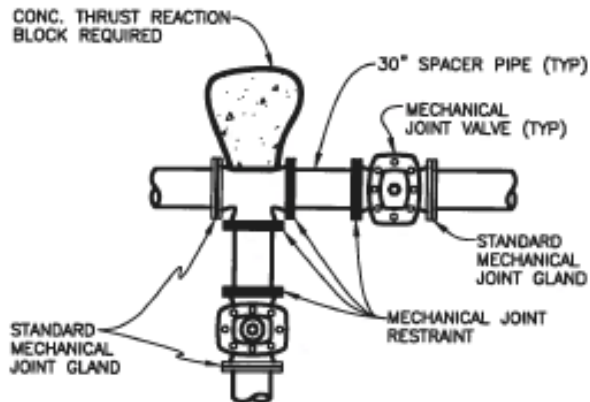

TEE INSTALLATION

NOTES:

- MECHANICAL JOINTS SHALL BE APPROVED ACCORDING TO MATERIAL SPECIFICATION FOR DIP AND PVC PIPE.
- SLIP JOINT DIP WITH UNIFLANGE RESTRAINED CLAMPS SHALL NOT BE USED IN LIEU OF MECHANICAL JOINT PIPE WITH MECHANICAL JOINT RESTRAINT.
- LENGTH OF PIPE REQUIRING JOINT RESTRAINT SHALL BE DETERMINED FROM THE CHART ON DWG-28.
- RESTRAINED JOINT PVC PIPE SHALL NOT BE USED FOR LOWERINGS.



APPLICATIONS FOR MECHANICAL JOINT RESTRAINTS

DRAWN: GSM	REVISED:	W-27
DATE: JAN. 04	REVISED:	
SCALE: NONE	REVISED:	

G:\DONALAS\STDSPESCS\Water\DWG-27.DWG, Layout1, 4/27/2018 8:48:19 AM, sc, Xerox AltaLink C8035, 1:1

RESTRAINED PIPE LENGTH (FT)

6-INCH DUCTILE IRON AND PVC

TYPE OF FITTING	STATIC PRESSURE (PSI)		
	<100	100-150	150-200
90° BEND, TEE, VALVE OR PLUG	31	47	62
45° BEND	13	19	25
22-1/2° BEND	6	8	11
11-1/4° BEND	3	5	6

8-INCH DUCTILE IRON AND PVC

TYPE OF FITTING	STATIC PRESSURE (PSI)		
	<100	100-150	150-200
90° BEND, TEE, VALVE OR PLUG	39	58	78
45° BEND	17	24	33
22-1/2° BEND	8	12	16
11-1/4° BEND	5	6	8

12-INCH DUCTILE IRON ONLY

TYPE OF FITTING	STATIC PRESSURE (PSI)		
	<100	100-150	150-200
90° BEND, TEE, VALVE OR PLUG	56	84	112
45° BEND	23	35	47
22-1/2° BEND	11	17	22
11-1/4° BEND	6	8	11

NOTES:

1. PRESSURES GREATER THAN 200 PSI REQUIRE SPECIAL DESIGN APPROVED BY THE DISTRICT.
2. LENGTH IS BASED ON MINIMUM 5'-0" OF GROUND COVER AND SOIL COMPACTED ACCORDING TO SECTION 5.15 OF THESE SPECIFICATIONS.
3. APPROVED METHODS OF RESTRAINED PIPE BEYOND INITIAL FITTING SHALL BE:
 - A. FOR DUCTILE IRON PIPE, 1100 SERIES MEGALUG BY EBAA IRON OR EQUAL ON MECHANICAL JOINT PIPE OR DOUBLE 1100 SERIES MEGALUG BY EBAA IRON OR EQUAL ON PUSH ON JOINT PIPE.
 - B. FOR PVC PIPE, SERIES 1500 OR SERIES 2800 RESTRAINTS BY EBAA IRON OR EQUAL.



RESTRAINED M.J. PIPE LENGTH DATA

DRAWN: GSM	REVISED:
DATE: JAN. 04	REVISED:
SCALE: NONE	REVISED:

W-28

G:\DONALAI\A\STD\SPES\IV\ale\DWG-28.DWG, I:\p\out1_4/27/2019, 8:49:43 AM, sc, Xerox, Altalink, C8005, 14

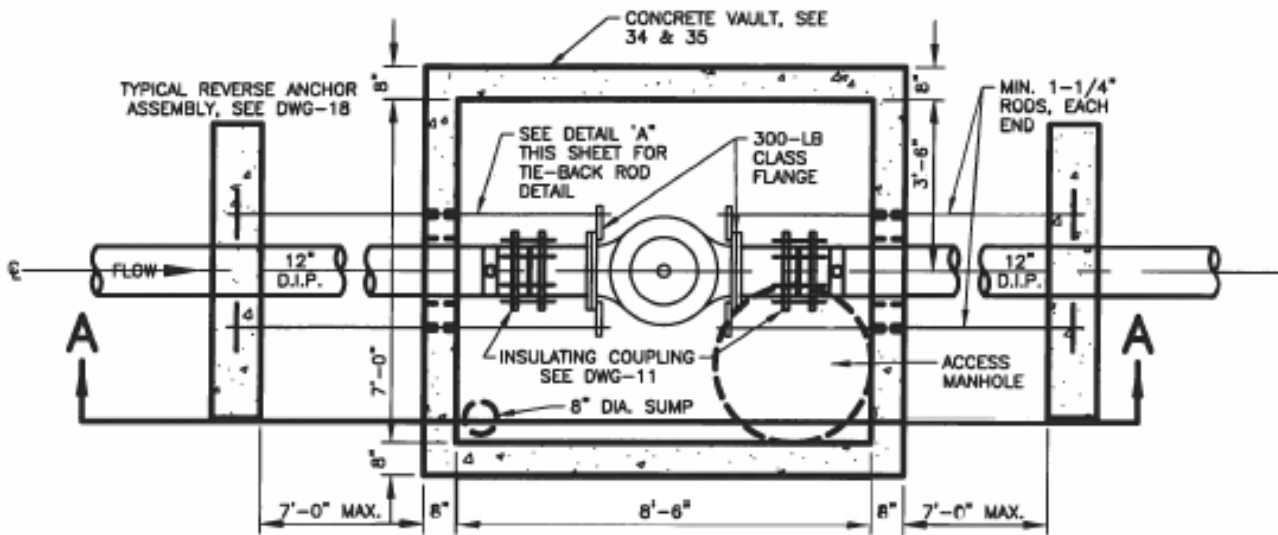

PLAN

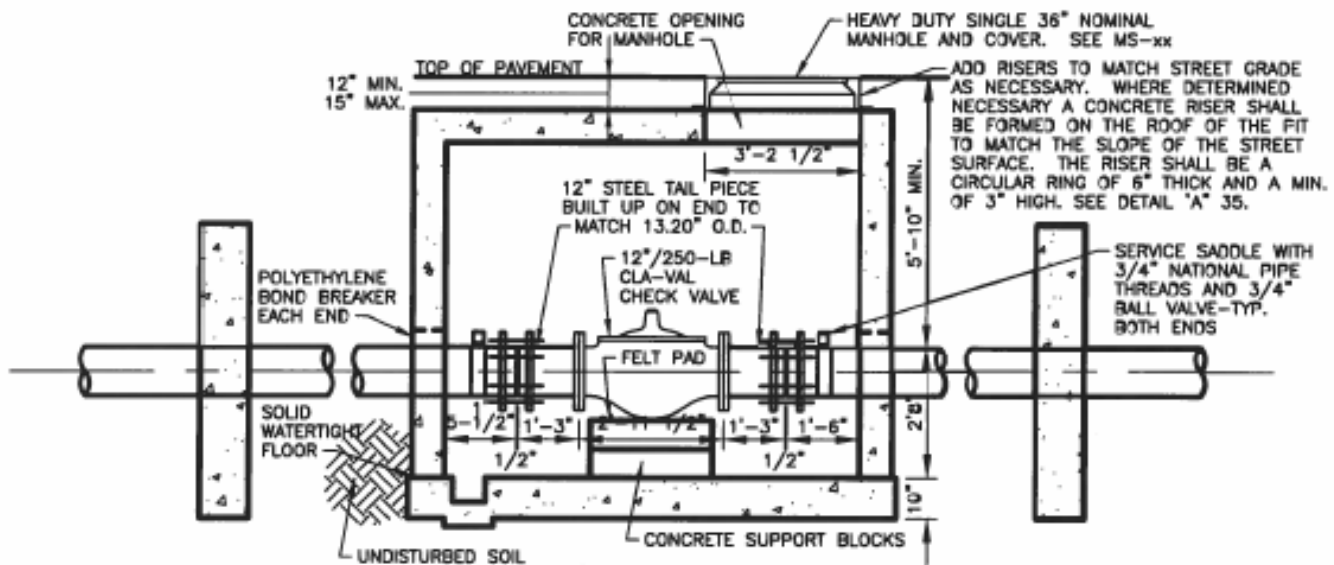

SECTION A-A

GENERAL NOTES

1. FOR VALVE INSTALLATIONS LESS THAN 12 INCH SIZE, DIMENSIONS SHALL BE ADJUSTED AT EACH END OF PIT.
2. CONCRETE VAULTS SHALL MEET ALL CRITERIA AS OUTLINED ON STANDARD DRAWINGS DWG-34 AND DWG-35.

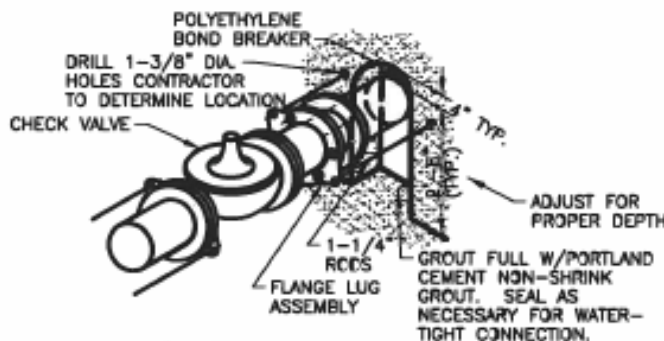

DETAIL 'A' - Pipe Arch



DONALA WATER & SANITATION DISTRICT

12-INCH CHECK VALVE STATION

DRAWN: XXX	REVISED: OCTOBER 1998
DATE: OCT 1998	REVISED: OCTOBER 1998
SCALE: NONE	REVISED: OCTOBER 1998

W-29

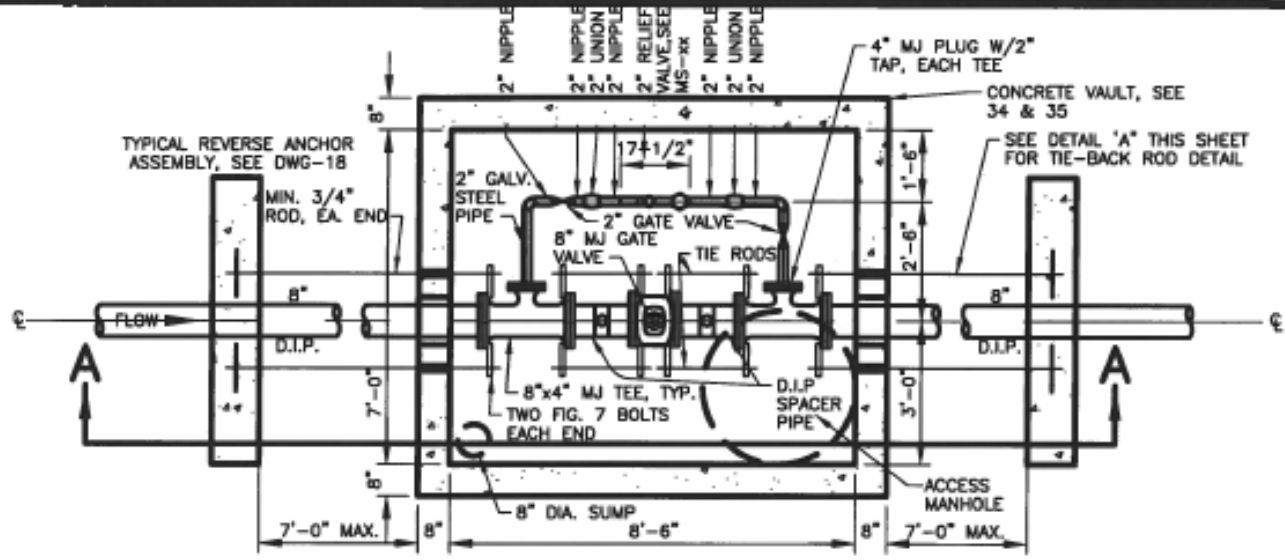

PLAN

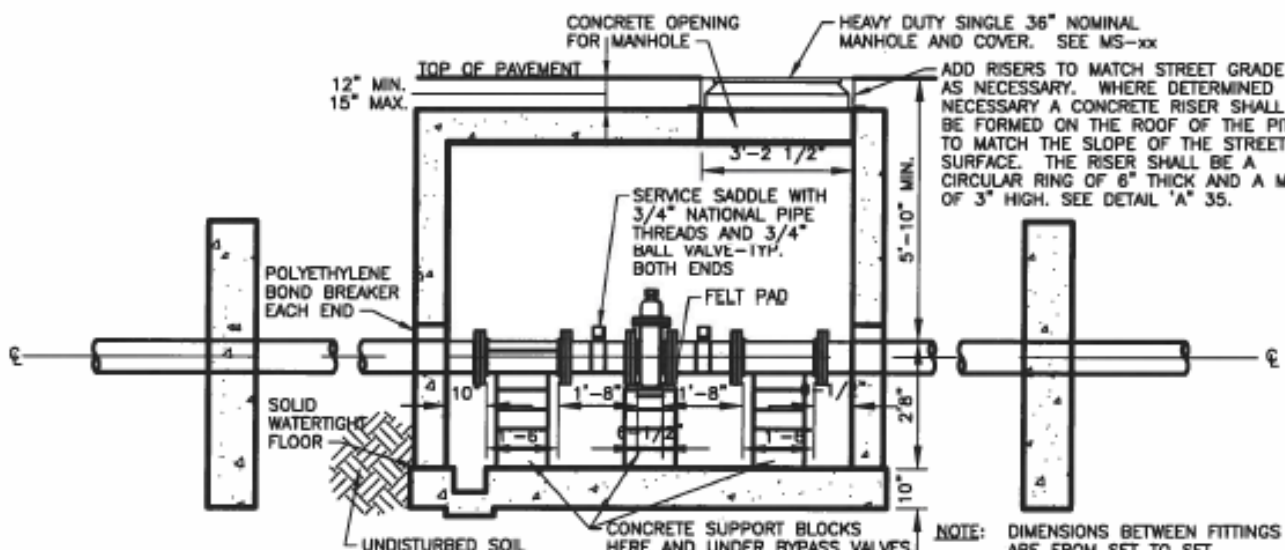

SECTION A-A

GENERAL NOTES

1. MECHANICAL JOINT RESTRAINTS MAY BE USED INSTEAD OF TIE RODS BETWEEN TEES AND VALVES.
2. CONTRACTOR SHALL DETERMINE DIMENSIONS OF ALL 2-INCH SIZE MATERIAL FOR PROPER INSTALLATION.
3. CONCRETE VAULTS SHALL MEET ALL CRITERIA AS OUTLINED ON STANDARD DRAWINGS 34 AND 35.

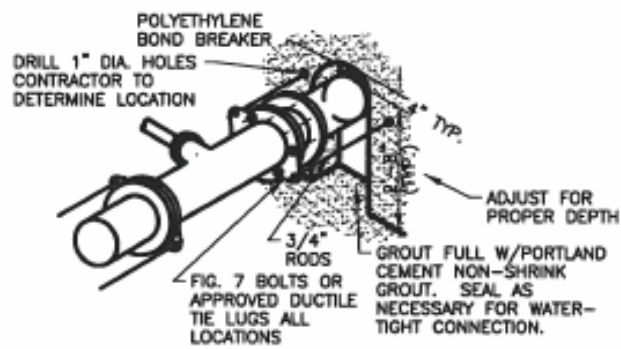

DETAIL 'A' - Pipe Arch



DONALA WATER & SANITATION DISTRICT

PRESSURE RELIEF STATION

DRAWN: GSM	REVISED:
DATE: JAN. 04	REVISED:
SCALE: NONE	REVISED:

W-30

G:\DONALAVISTD\SPECS\W&S\DWG-30.DWG, Layout1, 4/27/2018 8:50:35 AM, sc, Xerox, Altalink, C6095, 1/1

2 EA. HARNESS, LUGS AND ROD SETS (EACH SIDE). SIZE HOLES IN LUGS FOR RODS AND INSULATING SLEEVES.

RESTRAINING RODS SEE LEGEND
CONCRETE VAULT, SEE 34 & 35

BUILT UP ENDS TO MATCH CONNECTING PIPE

PIPE SIZE AND TYPE VARIES
REDUCER IF REQUIRED

TYPICAL REVERSE ANCHOR ASSEMBLY, SEE 18

PLAN LEGEND

- Ⓐ 8" STYLE 39 DRESSER COUPLING OR EQUAL (SEE DWG-11)
- Ⓑ 300LB FLANGES
- Ⓒ 4" 250LB GATE VALVE
- Ⓓ 4" 250LB CLA-VAL REGULATOR
- Ⓔ 4" STEEL FITTING, 300LB FLANGE ONE END, SPIGOT ONE END 1'-3" LONG
- Ⓕ 4" 150LB DRESSER STYLE 128 FLANGED ADAPTER OR EQUAL—TIE BACK TO REGULATOR WITH TWO 3/4" RODS. SEE PLAN VIEW.
- Ⓖ 4" 150LB GATE VALVE
- Ⓞ CLASS 'E' FLANGES

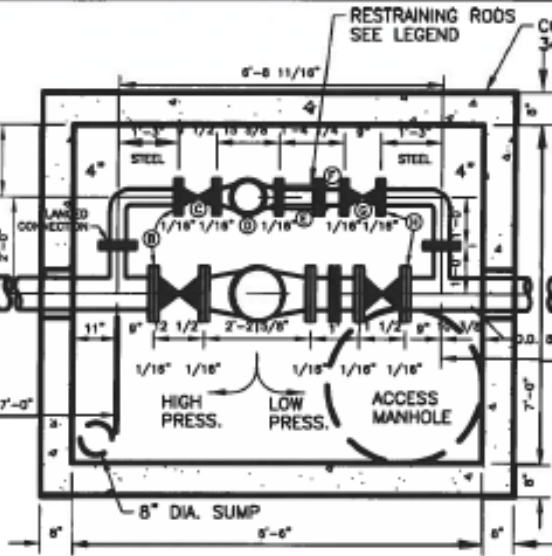

PLAN
(NO SCALE)

CONCRETE OPENING FOR MANHOLE
HEAVY DUTY SINGLE 36" NOMINAL MANHOLE AND COVER. SEE MS-xx

ADD RISERS TO MATCH STREET GRADE AS NECESSARY. WHERE DETERMINED NECESSARY A CONCRETE RISER SHALL BE FORMED ON THE ROOF OF THE PIT TO MATCH THE SLOPE OF THE STREET SURFACE. THE RISER SHALL BE A CIRCULAR RING OF 8" THICK AND A MIN. OF 3" HIGH. SEE DETAIL 'A' 35.

SEE DETAIL 'B' THIS SHEET FOR PIPE ARCH

NOTE: DIMENSIONS BETWEEN FITTINGS ARE FROM SET TO SET.

GENERAL NOTES

1. CONCRETE VAULTS SHALL MEET ALL CRITERIA AS OUTLINED ON STANDARD DRAWINGS 34 AND 5.
2. ALL REGULATOR INSTALLATIONS LARGER THAN 8-INCH SHALL BE SPECIALLY DESIGNED AND APPROVED BY THE WATER DEPARTMENT.

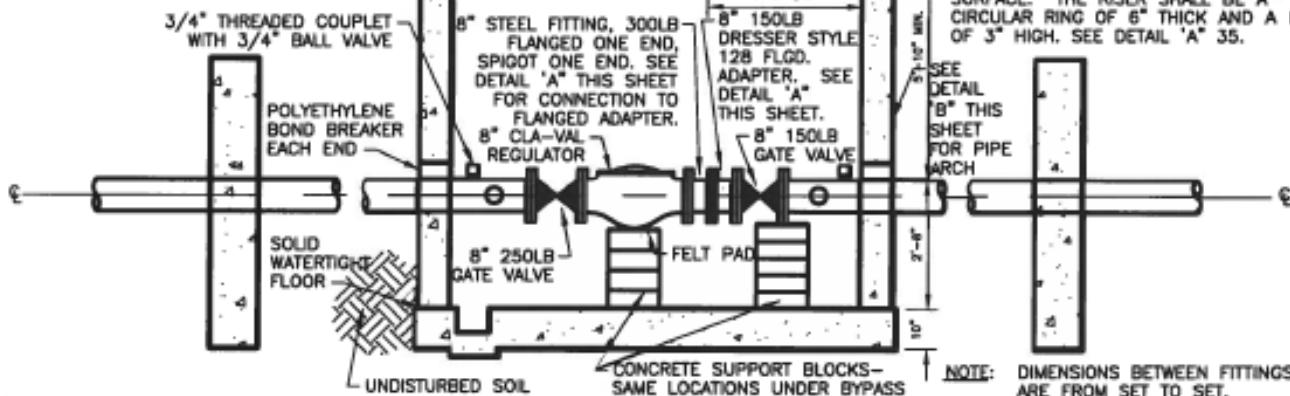

ELEVATION
(NO SCALE)

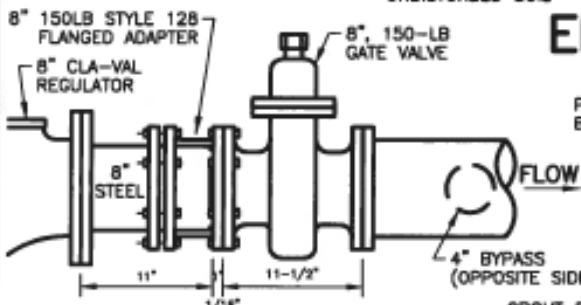

DETAIL 'A'
Flanged Adapter
(NO SCALE)

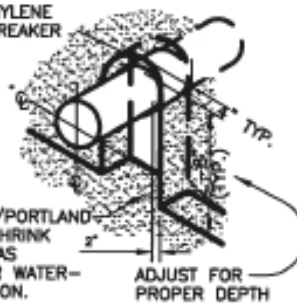

DETAIL 'B'
Pipe Arch
(NO SCALE)

GROUT FULL W/PORTLAND CEMENT NON-SHRINK GROUT. SEAL AS NECESSARY FOR WATER-TIGHT CONNECTION.

ADJUST FOR PROPER DEPTH

FITTING LENGTH (USE 1'-3" LONG STEEL FITTING FOR 4" ADAPTER INSTALLATION)

4" BYPASS (OPPOSITE SIDE)

POLYETHYLENE BOND BREAKER



DONALA WATER & SANITATION DISTRICT

8-INCH SIZE PRESSURE REGULATOR STATION

DRAWN: GSM

REVISED:

DATE: JAN. 04

REVISED:

SCALE: NONE

REVISED:

W-31

2 EA. HARNESS, LUGS AND ROD SETS (EACH SIDE). SIZE HOLES IN LUGS FOR RODS AND INSULATING SLEEVES.

- CONCRETE VAULT, SEE 34 & 35

RESTRAINING RODS SEE LEGEND

BUILT UP ENDS TO MATCH CONNECTING PIPE

PIPE SIZE AND TYPE VARIES

REDUCER IF REQUIRED

TYPICAL REVERSE ANCHOR ASSEMBLY, SEE 18

PLAN LEGEND

- Ⓐ 6" STYLE 39 DRESSER COUPLING OR EQUAL (SEE DWG-11)
- Ⓑ 300LB FLANGES
- Ⓒ 4" 250LB CLA-VAL REGULATOR
- Ⓓ 4" 250LB GATE VALVE
- Ⓔ 4" STEEL FITTING, 300LB FLANGE ONE END, SPIGOT ONE END 1'-3" LONG
- Ⓕ 4" 150LB DRESSER STYLE 128 FLANGED ADAPTER OR EQUAL-TIE BACK TO REGULATOR WITH TWO 3/4" RODS. SEE PLAN VIEW.
- Ⓖ 4" 150LB GATE VALVE
- Ⓗ CLASS 'E' FLANGES

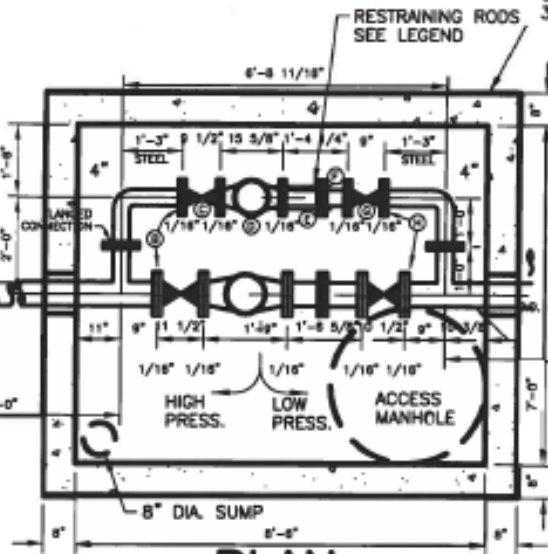

PLAN
(NO SCALE)

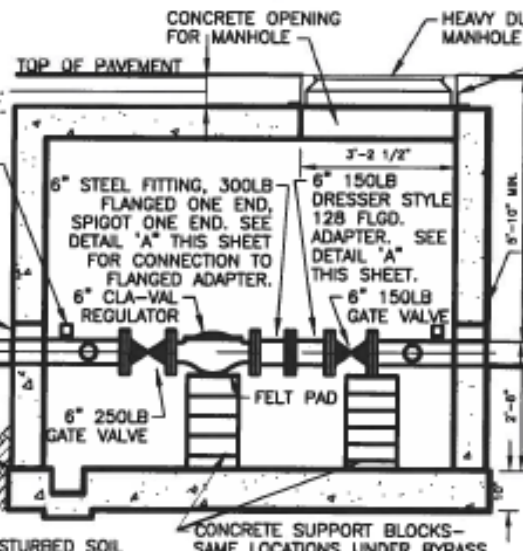

ELEVATION
(NO SCALE)

ADD RISERS TO MATCH STREET GRADE AS NECESSARY. WHERE DETERMINED NECESSARY A CONCRETE RISER SHALL BE FORMED ON THE ROOF OF THE PIT TO MATCH THE SLOPE OF THE STREET SURFACE. THE RISER SHALL BE A CIRCULAR RING OF 6" THICK AND A MIN. OF 3" HIGH. SEE DETAIL 'A' 35.

NOTE: DIMENSIONS BETWEEN FITTINGS ARE FROM SET TO SET.

GENERAL NOTES

1. CONCRETE VAULTS SHALL MEET ALL CRITERIA AS OUTLINED ON STANDARD DRAWINGS 34 AND 35.
2. ALL REGULATOR INSTALLATIONS LARGER THAN 8-INCH SHALL BE SPECIALLY DESIGNED AND APPROVED BY THE DISTRICT.

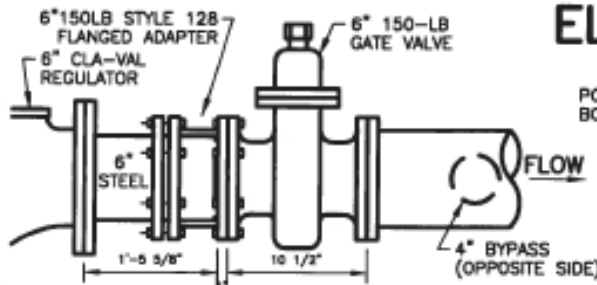

DETAIL 'A'
Flanged Adapter
(NO SCALE)

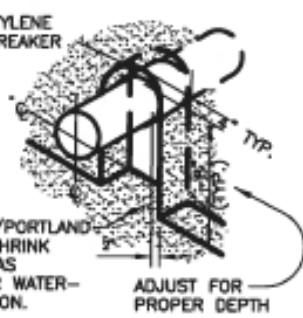

DETAIL 'B'
Pipe Arch
(NO SCALE)

G:\DONALA\ISTD\SP\ECN\Hand\DWG-52.DWG, I layout, #1272018, 8:42:06 AM, so, Xerox, Altalink, C9035, 1:1



DONALA WATER & SANITATION DISTRICT

6-INCH SIZE PRESSURE REGULATOR STATION

DRAWN: DAB	REVISED:
DATE: JAN. 04	REVISED:
SCALE: 1' = 10'	REVISED:

W-32

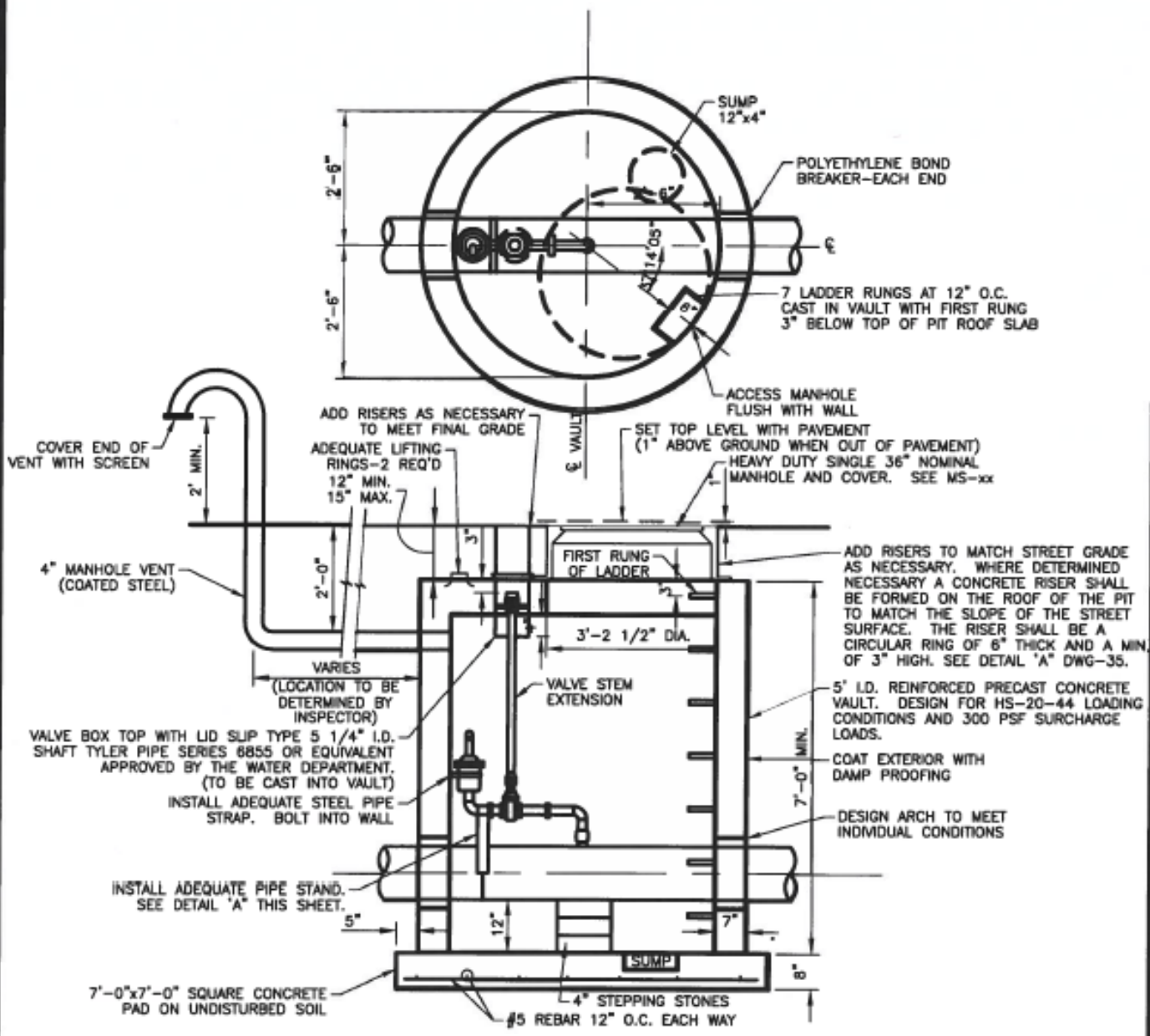

LEGEND

- Ⓐ 2" CORPORATION TAPERED THREADS INLET WITH 2" FEMALE IRON PIPE OUTLET(MUELLER OR FORD)
- Ⓑ 2"xCLOSE THREADED BRASS NIPPLE
- Ⓒ 2" THREADED GATE VALVE WITH STANDARD OPENING NUT
- Ⓓ 2" THREADED INLET CRISPIN AIR AND VACUUM VALVE-SEE MS-xx
- Ⓔ 2"x90° PLASTIC ELBOW
- Ⓕ 2"x90° BRASS BRASS THREADED ELBOW
- Ⓖ 2" BRASS UNION
- Ⓗ 2"x4" THREADED BRASS NIPPLE

GENERAL NOTES

1. ALL CONCRETE WORK SHALL COMPLY WITH THE LATEST ACI-318 SPECIFICATIONS.
2. AIR VALVE ASSEMBLY LARGER THAN 2" SIZE OR FOR MAINS LARGER THAN 16" SHALL BE SPECIALLY DESIGNED AND MEET THE WATER DEPARTMENT REQUIREMENTS.
3. ALL SUPPORT MATERIALS SHALL BE GIVEN 2 COATS OF RUST INHIBITIVE PAINT.
4. ALL LADDER RUNGS MUST LINE UP BOTH HORIZONTALLY AND VERTICALLY.
5. ALL SMALL DIA. PIPE AND AIR RELEASE SHALL BE WRAPPED WITH INSULATION AND TAPED

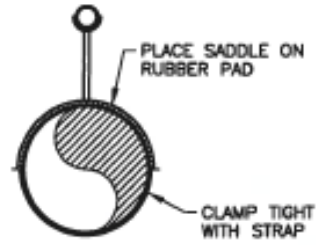

DETAIL 'A'
Pipe Stand
(NO SCALE)



2" AIR AND VACUUM VALVE STATION		
DRAWN: GSM	REVISED:	
DATE: JAN.04	REVISED:	
SCALE: NONE	REVISED:	
		W-33

C:\DONAL\A\STD\SPCS\WATER\DWG-33.DWG | layout_4/27/2018 10:18:57 AM, gc, Xerox Allright C6085, 1:1

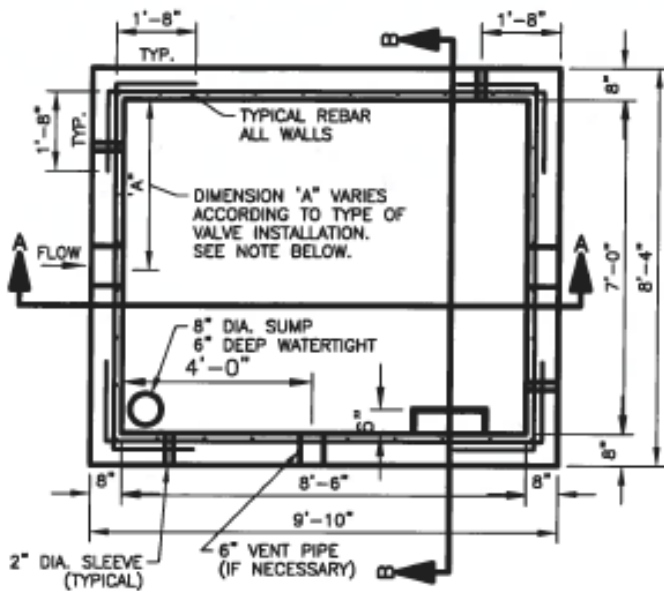

PLAN

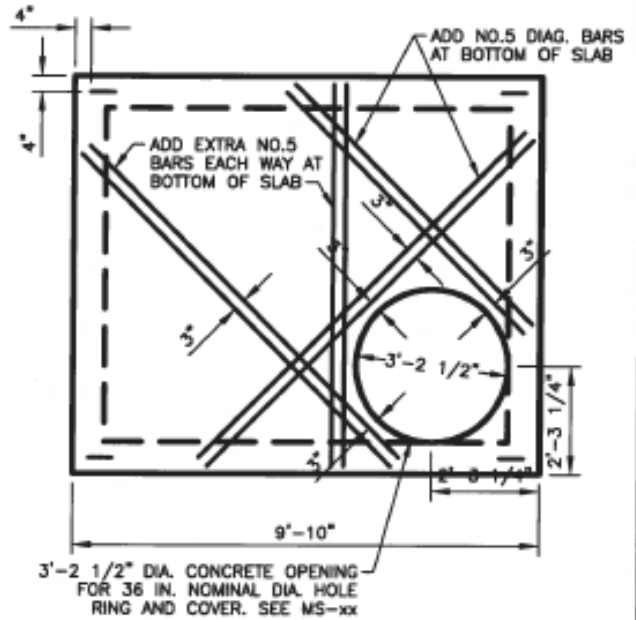

ROOF PLAN

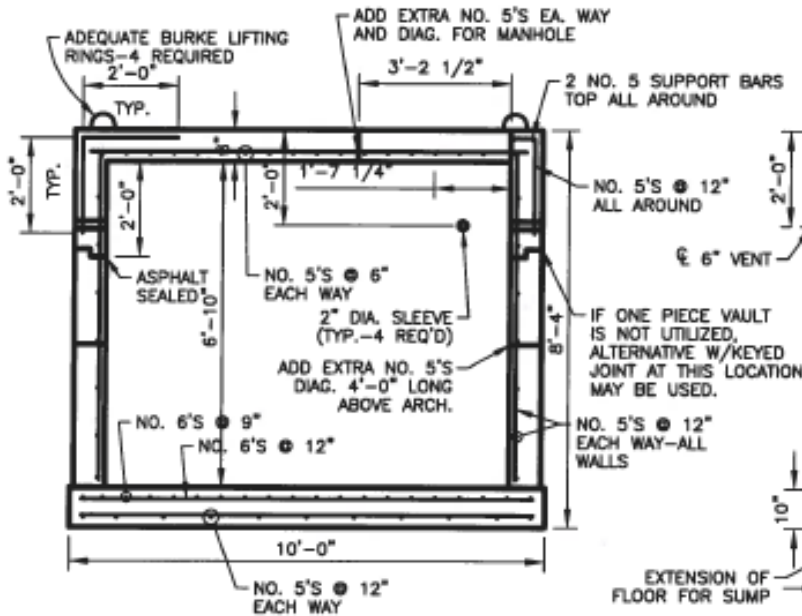

SECTION A-A

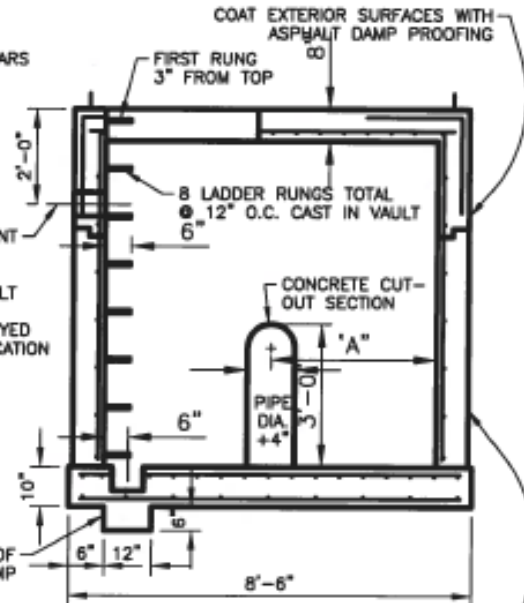

SECTION B-B

NOTES

DIMENSION 'A' = 3'-6" FOR 8,31,32
= 4'-0" FOR 30

ALL CONCRETE WORK SHALL COMPLY WITH DISTRICT STANDARD SPECIFICATIONS AND LATEST A.C.I.-318 CODE.

MINIMUM CONCRETE CLEARANCES FOR REBAR:
-3" WHERE POURED AGAINST THE GROUND.
-2" WHERE FORMED AND THEN EXPOSED TO GROUND OR WEATHER FOR NO. 8 OR LARGER, 1 1/2" FOR NO. 5 AND SMALLER.
-1" WHERE EXPOSED TO INTERIOR SURFACES.
-ALL VAULTS SHALL BE CONSTRUCTED TO MEET HS 20-44 TRAFFIC LOADING CONDITIONS AND 300 PSF SURCHARGE LOAD.

INSTALL CONSEAL (OR APPROVED URETHANE CHEMICAL GROUT WHEN REQUIRED BY OWNER) BETWEEN FLOOR AND WALL AS WATER-TIGHT SEALER

STANDARD CONCRETE VAULT FOR VALVE INSTALLATION-PRECAST



DONALA WATER & SANITATION DISTRICT

DRAWN: GSM	REVISED:
DATE: JAN.04	REVISED:
SCALE: NONE	REVISED:

W-34

G:\2018\LISTS\STDSPECS\Water\DWG-35.DWG, Layout1, 4/27/2018 10:32:20 AM, sc_Xerox Alvalick C8035, 1:1

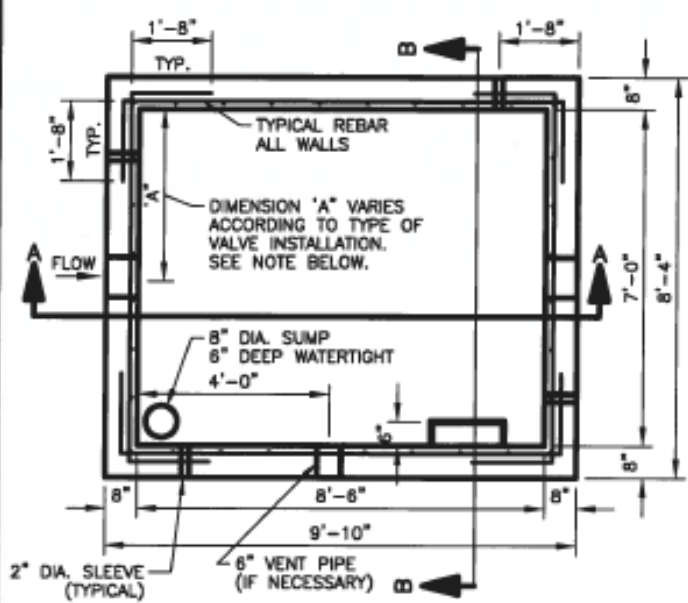

PLAN

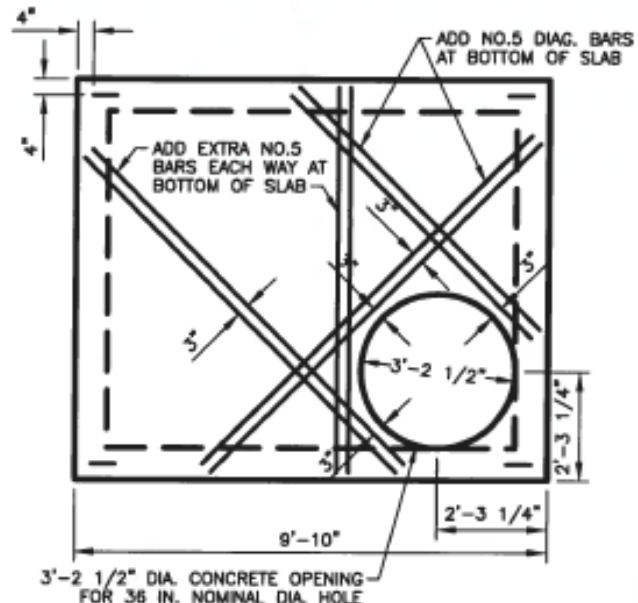

ROOF PLAN

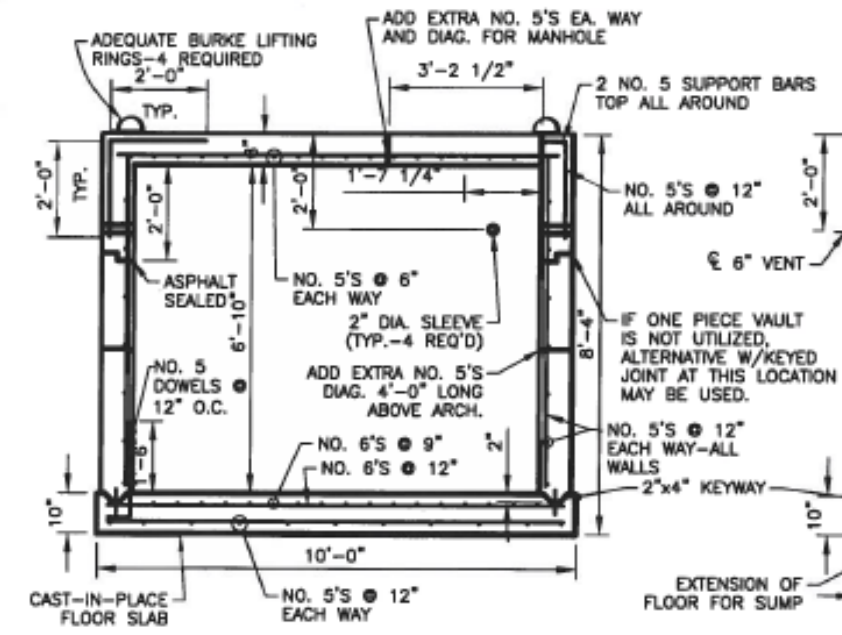

NOTES SECTION A-A

DIMENSION 'A' = 3'-6" FOR 28,31,32
= 4'-0" FOR 30

ALL CONCRETE WORK SHALL COMPLY WITH DISTRICT STANDARD SPECIFICATIONS AND LATEST A.C.I.-318 CODE.

MINIMUM CONCRETE CLEARANCES FOR REBAR:
-3" WHERE POURED AGAINST THE GROUND.
-2" WHERE FORMED AND THEN EXPOSED TO GROUND OR WEATHER FOR NO. 6 OR LARGER, 1 1/2" FOR NO. 5 AND SMALLER.
-1" WHERE EXPOSED TO INTERIOR SURFACES
-ALL VAULTS SHALL BE CONSTRUCTED TO MEET HS 20-44 TRAFFIC LOADING CONDITIONS AND 300 PSF SURCHARGE LOAD.
-THE DISTRICT MAY REQUIRE A PRECAST VAULT WHEN WEATHER OR OTHER FIELD CONDITIONS WARRANT. SEE DWG-34.

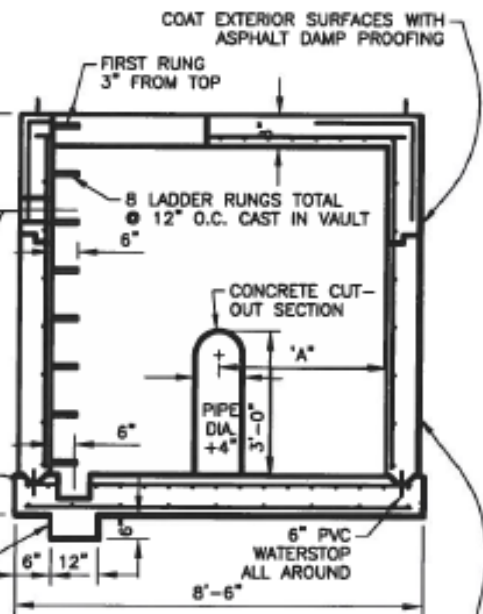

SECTION B-B

INSTALL CONSEAL (OR APPROVED URETHANE CHEMICAL GROUT WHEN REQUIRED BY OWNER) BETWEEN FLOOR AND WALL AS WATER-TIGHT SEALER

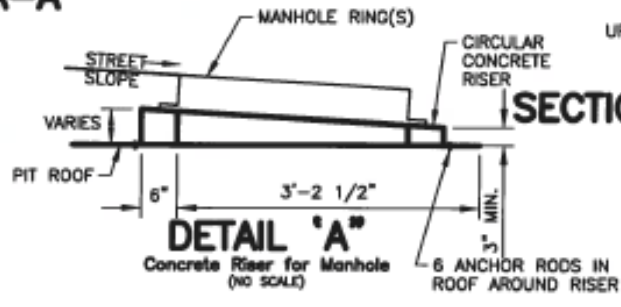

DETAIL 'A'

STANDARD CONCRETE VAULT FOR VALVE INSTALLATION-CAST IN PLACE



DONALA WATER & SANITATION DISTRICT

DRAWN: GSM	REVISED:
DATE: JAN.04	REVISED:
SCALE: NONE	REVISED:

W-35

METAL IN CONCRETE:

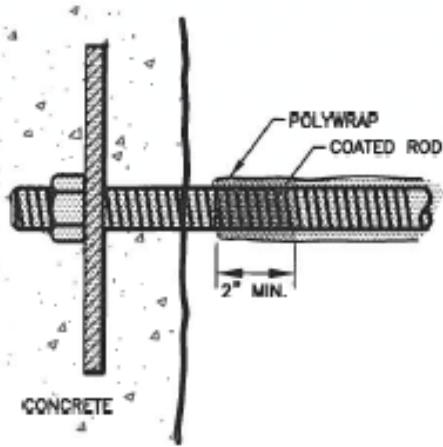

NO SCALE

1. COAT METAL PARTS WHERE IN CONTACT WITH CONCRETE, EXTENDING COATING SEVERAL INCHES BEYOND THE CONCRETE.
2. POLYWRAP THE ROD, OVERLAPPING THE POLYWRAP AND THE COATING A MINIMUM OF 2".
3. SECURE POLYWRAP TO THE ROD USING 2" WIDE, 10-MIL POLYETHYLENE PRESSURE-SENSITIVE TAPE.

ROD THROUGH I-BEAM:

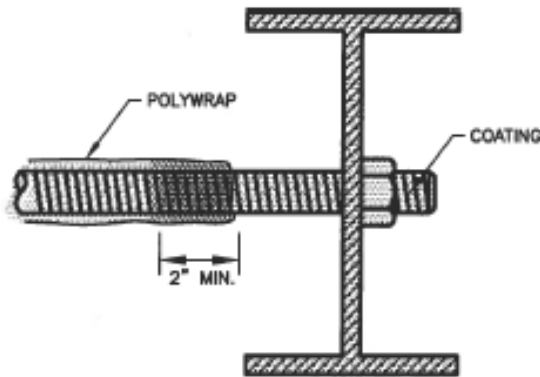

NO SCALE

1. COAT ENTIRE I-BEAM.
2. COAT NUT AND ROD, EXTENDING COATING SEVERAL INCHES BEYOND THE BEAM.
3. POLYWRAP THE ROD, OVERLAPPING THE COATING A MINIMUM OF 2".
4. SECURE POLYWRAP WITH TAPE.

RODS IN MJ FITTING:

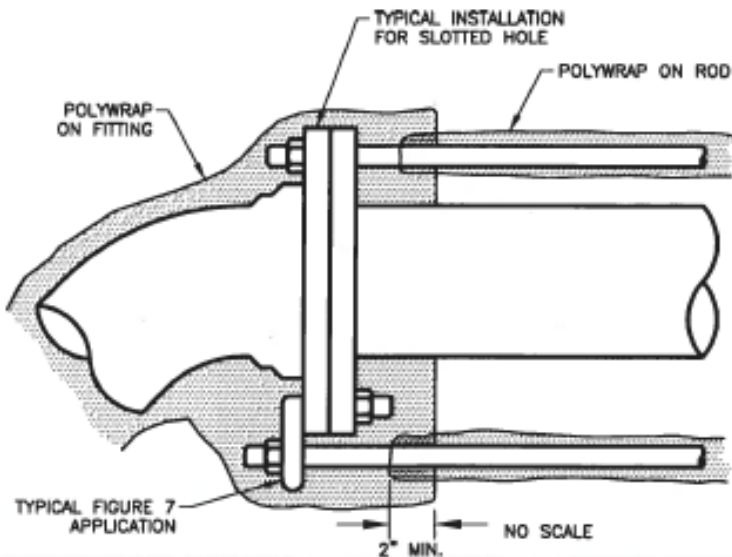

1. POLYWRAP THE ROD AND SECURE WITH TAPE.
2. POLYWRAP THE FITTING, OVERLAPPING THE POLYWRAP ON THE ROD A MINIMUM OF 2" AND SECURE WITH TAPE.

PROTECTING TIE-RODS



DONALA WATER &
SANITATION DISTRICT

DRAWN: GSM

REVISED:

DATE: JAN. 04

REVISED:

SCALE: NONE

REVISED:

W-36

SERVICE TAPS 1-1/2" & 2" TAPPING SADDLE

SERVICE TAPS 3/4" & 1" CORPORATION ONLY

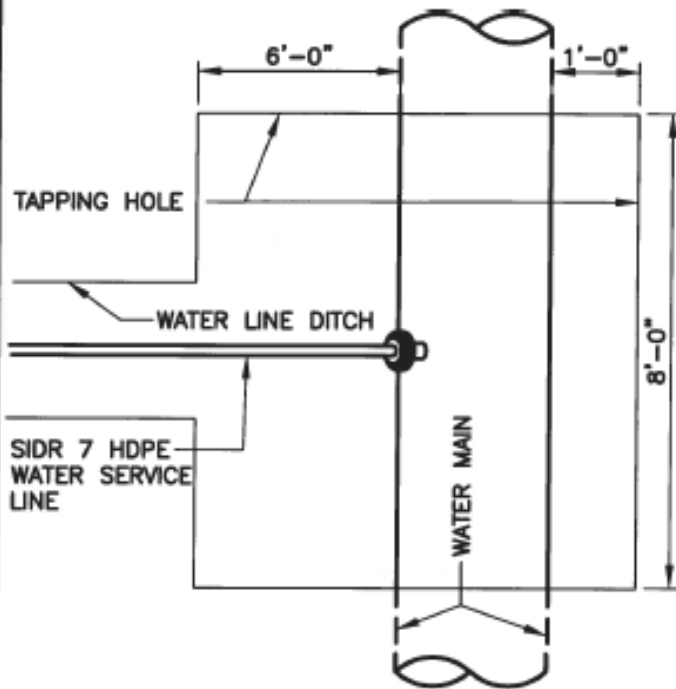

PLAN

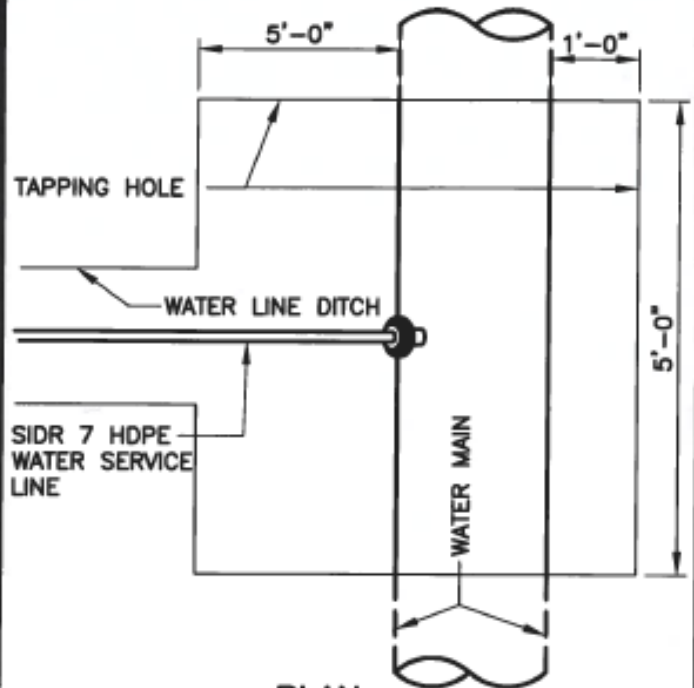

PLAN

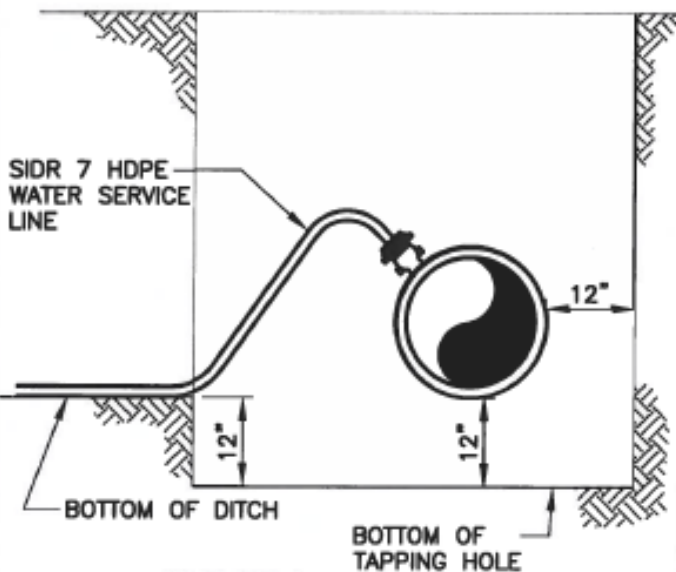

ELEVATION

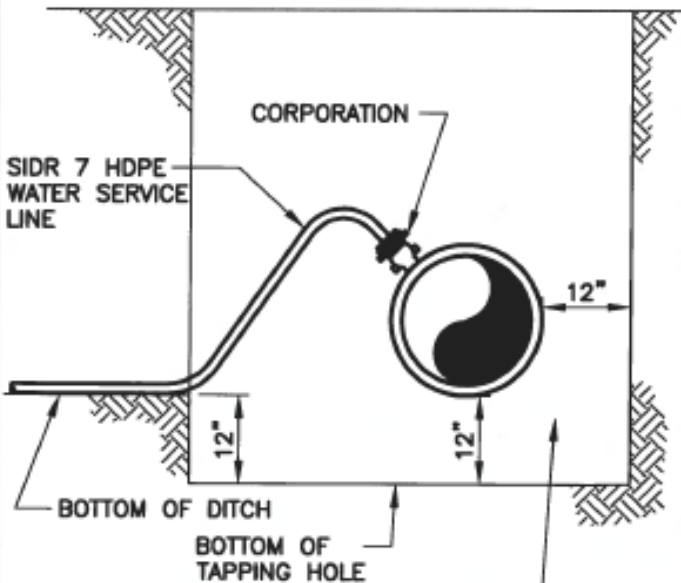

ELEVATION

NOTE:

DIRECT TAPS TO THE WATER MAIN SHALL BE MADE ONLY WHEN APPROVED BY THE DISTRICT. ALL TAPS SHALL USE TAPPING SADDLES. TAPPING SADDLES SHALL HAVE TWO STAINLESS STEEL BANDS AND A NYLON OR EPOXY COATED DUCTILE IRON BODY: MUELLER® DR2S OR APPROVED EQUAL.

ALLOW 12" CLEARANCE SURROUNDING MAIN FOR TAPPING MACHINE

TAPPING DETAIL 3/4" - 2"



DONALA WATER & SANITATION DISTRICT

DRAWN: GSM

REVISED: APRIL 26, 2018

DATE: JAN. 04

REVISED:

SCALE: NONE

REVISED: NOVEMBER 2014

W-37

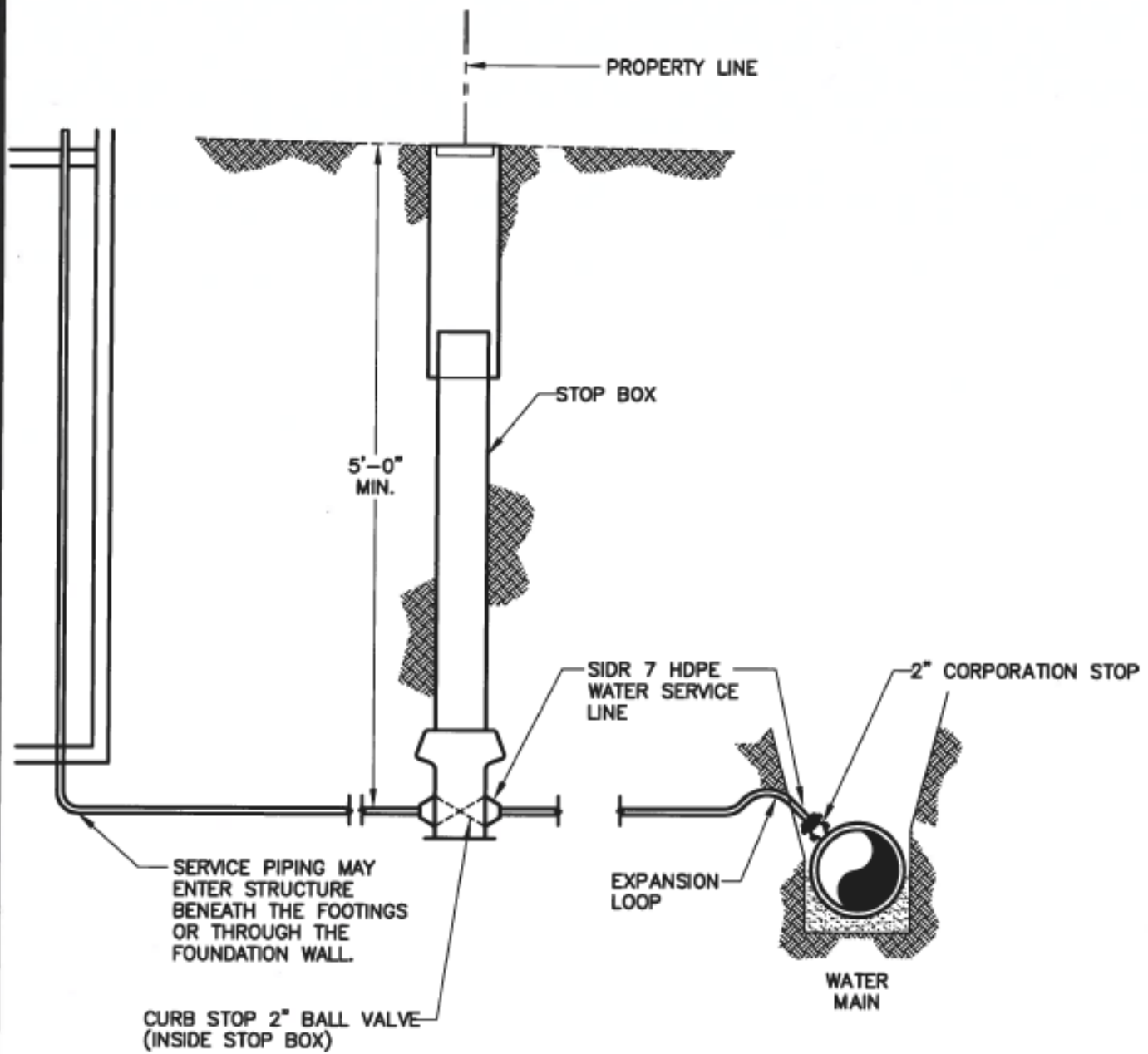

- NOTE:**
- 1) REFER TO STANDARD DRAWINGS FOR METER, PRESSURE REGULATION AND BACKFLOW PREVENTION DEVICE INSTALLATION DETAILS.
 - 2) SERVICE LINE FROM CURB STOP TO THE STRUCTURE BEING SERVED IS THE RESPONSIBILITY OF THE CUSTOMER/OWNER FOR OPERATION AND MAINTENANCE. ONLY THE DISTRICT IS AUTHORIZED TO OPEN AND CLOSE THE CORPORATION AND CURB STOP ONCE IN SERVICE.

G:\DONAL\A\STD\SPEC\W\Drawings\W-38.dwg, Layout1_4/27/2018 8:10:15 AM, sc, Xerox, Altalink, C8035, 11



TYPICAL INSTALLATION FOR SERVICE LINE, STOP BOX, AND METER		
DRAWN: GSM	REVISED: APRIL 26, 2018	W-38
DATE: JAN. 04	REVISED:	
SCALE: NONE	REVISED: NOVEMBER 2014	

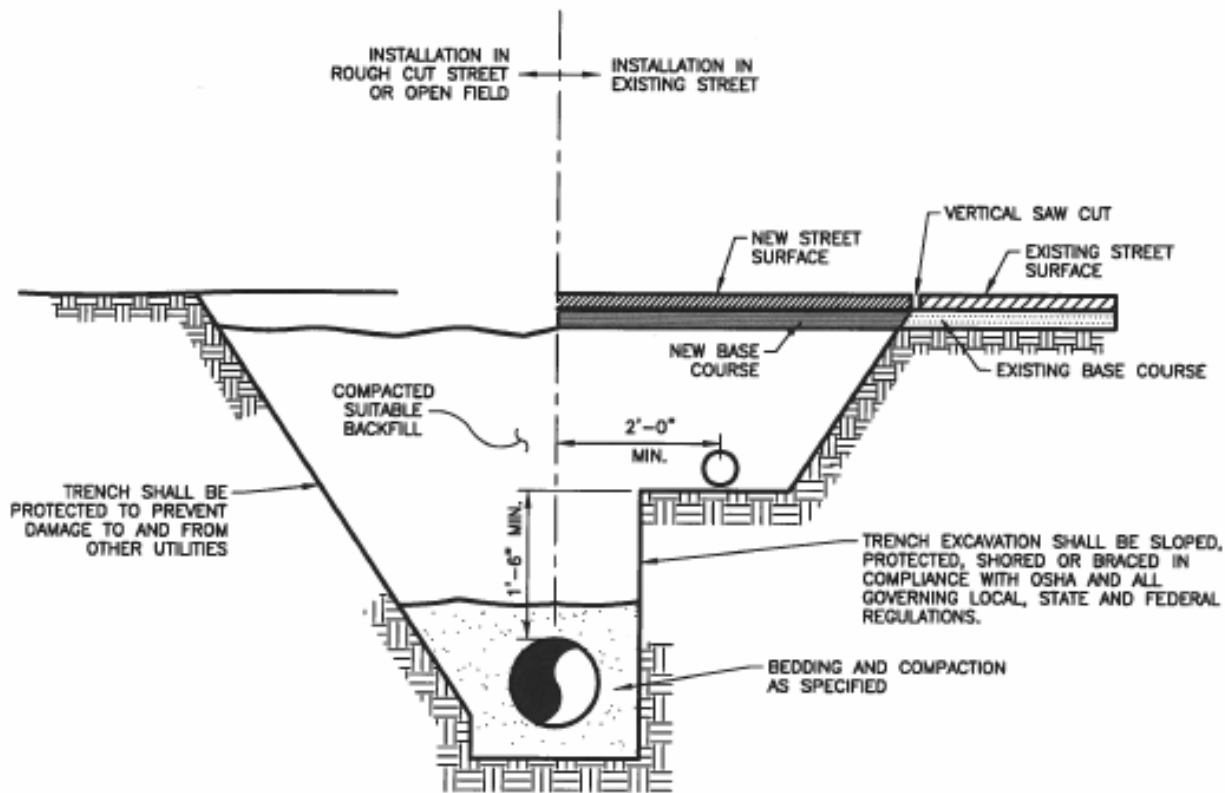

1. SPECIFIC CASE-BY-CASE APPROVAL BY THE DISTRICT SHALL BE REQUIRED PRIOR TO INSTALLATION OF WATER AND SEWER SERVICES IN A COMMON TRENCH.
2. USE OF COMMON TRENCH FOR WATER AND SEWER SERVICES SHALL NOT BE PERMITTED IN PUBLIC RIGHT-OF-WAY AND BETWEEN THE WATER CORPORATION STOP AND CURB STOP.
3. ALL MATERIALS AND INSTALLATION SHALL BE IN ACCORDANCE WITH THE SPECIFICATIONS AND ANY OTHER APPLICABLE CODE OR REGULATION.



DONALA WATER & SANITATION DISTRICT

TYPICAL SERVICE LINE TRENCH—COMMON DITCH FOR WATER OR SEWER

DRAWN: GSM	REVISED:	
DATE: JAN.04	REVISED:	
SCALE: NONE	REVISED:	

W-38A

C:\DONAL\A\STD\SPEC\Water\Draw-39.dwg, J:\avouid, 4/27/2018 10:17:01 AM, sc, Xerox Alltelink C8035, 1:1

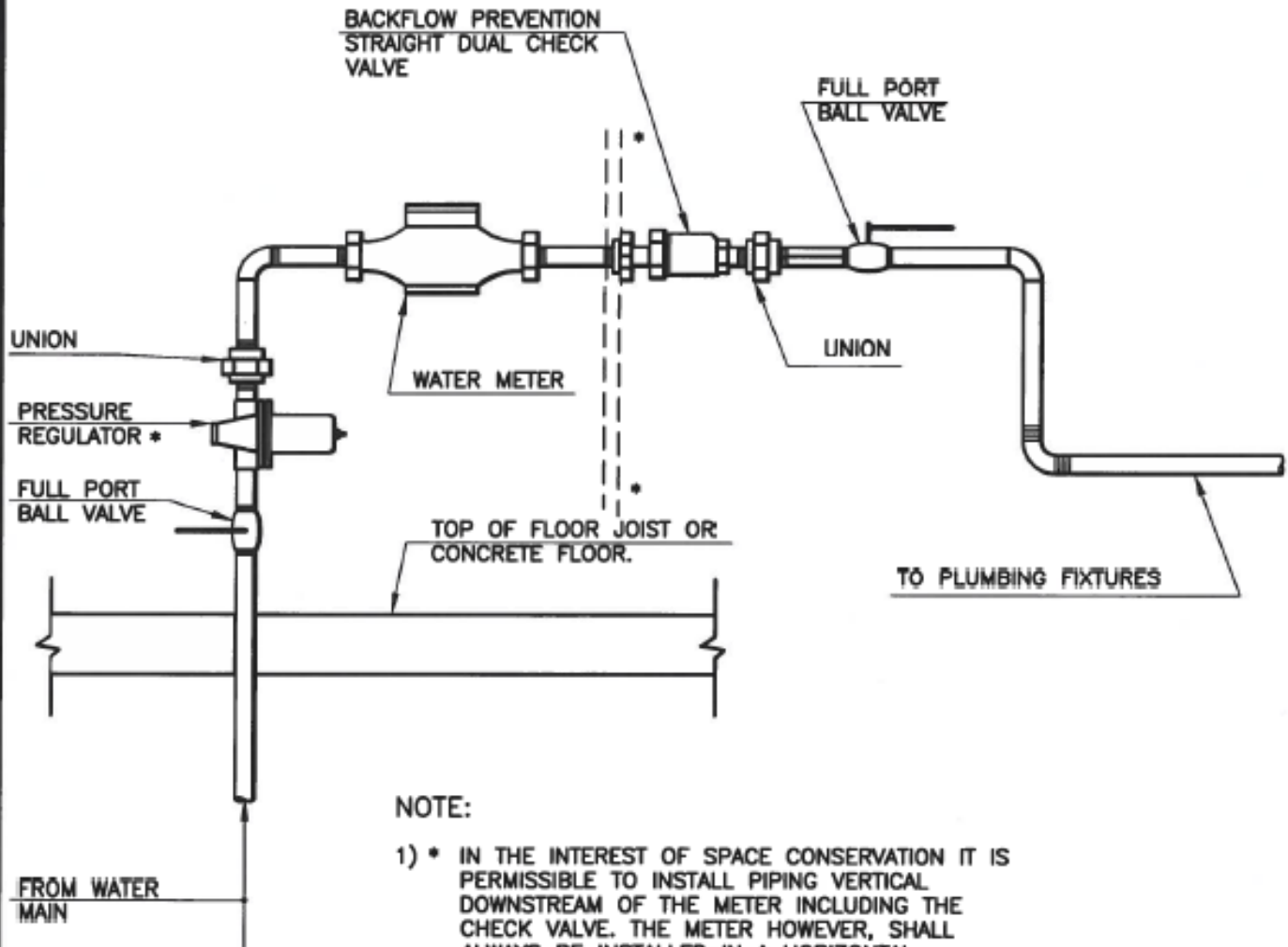

NOTE:

- 1) * IN THE INTEREST OF SPACE CONSERVATION IT IS PERMISSIBLE TO INSTALL PIPING VERTICAL DOWNSTREAM OF THE METER INCLUDING THE CHECK VALVE. THE METER HOWEVER, SHALL ALWAYS BE INSTALLED IN A HORIZONTAL POSITION. LIKEWISE, THE PRESSURE REGULATOR ON THE INLET SIDE OF THE METER MAY BE INSTALLED IN A HORIZONTAL OR VERTICAL POSITION.
- 2) A SECOND PRESSURE REGULATOR MAY BE INSTALLED ON THE DEMAND SIDE OF THE METER DOWNSTREAM FROM A BRANCH SUPPLYING AN IRRIGATION SYSTEM IF REQUIRED. THE IRRIGATION SYSTEM BRANCH MUST BE DOWNSTREAM OF THE METER, CHECK VALVE AND BALL VALVE.



DONALA WATER & SANITATION DISTRICT

WATER METER LOOP FOR 3/4" THRU 1" METERS

DRAWN: GSM	REVISED:	W-39
DATE: JAN. 04	REVISED:	
SCALE: NONE	REVISED:	

COMPACT BACKFILL PER SPECIFICATIONS.
GRADE SURFACE TO MATCH EXISTING.
RESTORE AS REQUIRED.

METER PIT LOCATION AS
DIRECTED IN THE FIELD.

3/4" OR 1" RESIDENTIAL
METER (PROVIDED BY OWNER)

CAST IRON LID SET 2"
ABOVE GROUND.

METER INLET WITH ANGLE VALVE
WITH LOCKING TAB.

LOCKING, FROST PROOF, DOUBLE
ALUMINUM COVER. SET PLUMB AND
TIGHTLY ON METER PIT.

VERTICAL METER SETTER WITH
FLARED COPPER CONNECTIONS,
CENTER IN PIT, SET PLUMB.

DISTANCE TO TOP OF
METER. 12" - 15"

SET PIT ON FIRMLY COMPACTED
BACKFILL OF 3/4" CRUSHED ROCK,
SET ROCK MIN. 6" BELOW AND 6" INTO
BASE OF PIT.

METER OUTLET CONNECTION
NEW 20"x36" FIBER METER PIT
NEW 3/4" OR 1" OUTLET LINE

CORPORATION STOP
AND TAPPING
SADDLE.

EXPANSION
LOOP

EXISTING OR NEW
WATER MAIN.

SIDR 7 HDPE
WATER SERVICE
LINE

ATTACH NEW PIPE WITH
FLARED COMPRESSION
FITTING FOR HDPE, SEE
SPECIFICATIONS FOR
OTHER MATERIALS.

G:\2018\AUSTID\SPEC\WilliamDwn-40.dwg, 8.5x11, 5/3/2018 1:55:54 PM, sr, Xerox, Altalink C8035, 1:1



DONALA WATER &
SANITATION DISTRICT

NEW SERVICE LINE/WATER PIT INSTALLATION

DRAWN: GSM	REVISED: MAY 2018
DATE: JAN. 04	REVISED:
SCALE: NONE	REVISED: NOVEMBER 2014

W-40

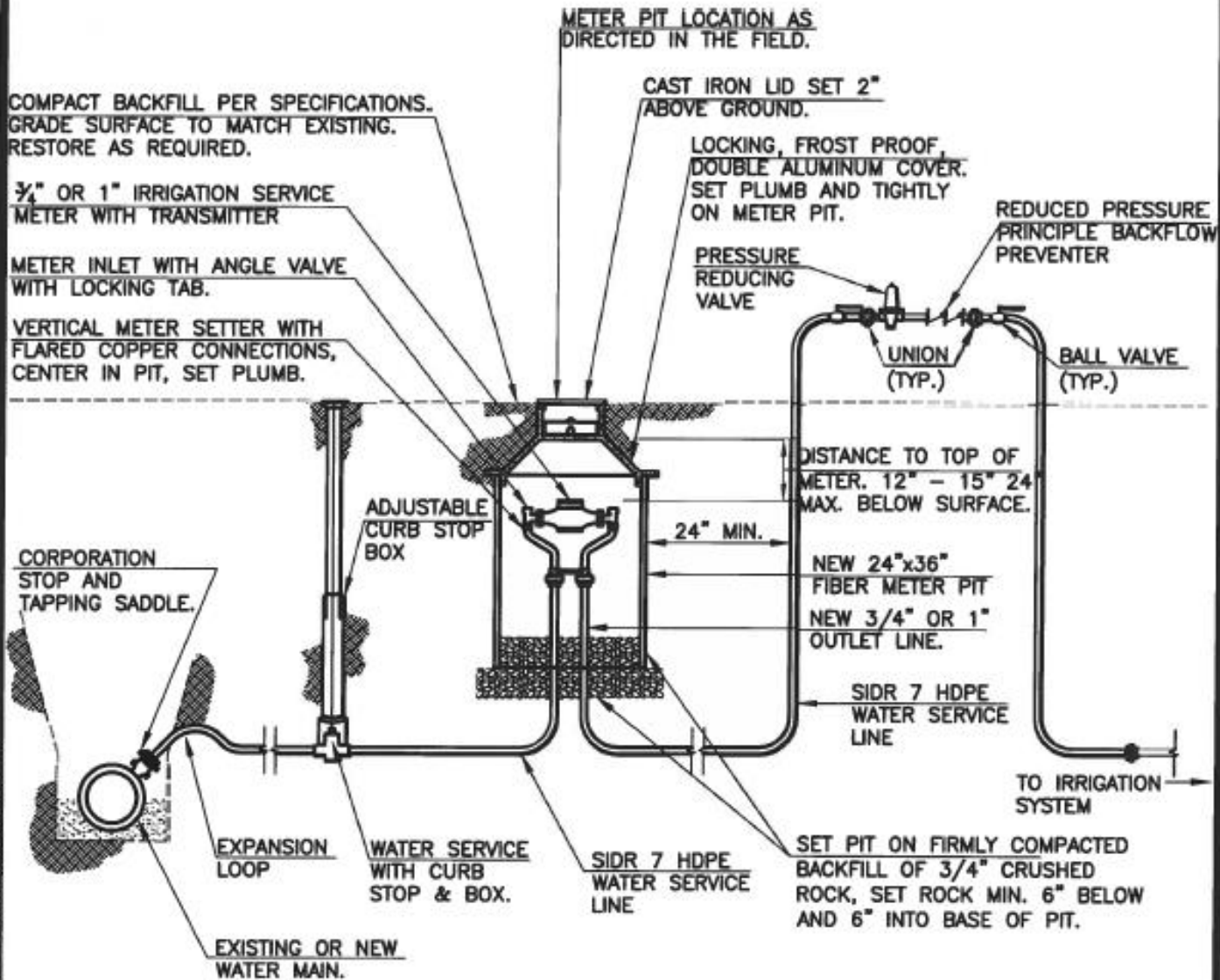

G:\DONAL_A\ISTDSPEC\Water\Doc-41.dwg, B.5x11, 5/23/2018 1:57:05 PM, gc, Xerox Allalink C6035, 1:1



IRRIGATION SERVICE 3/4" & 1" METER INSTALLATION		
DRAWN: RGG	REVISED: MAY 2018	
DATE: DEC. 05	REVISED:	
SCALE: NONE	REVISED:	W-41

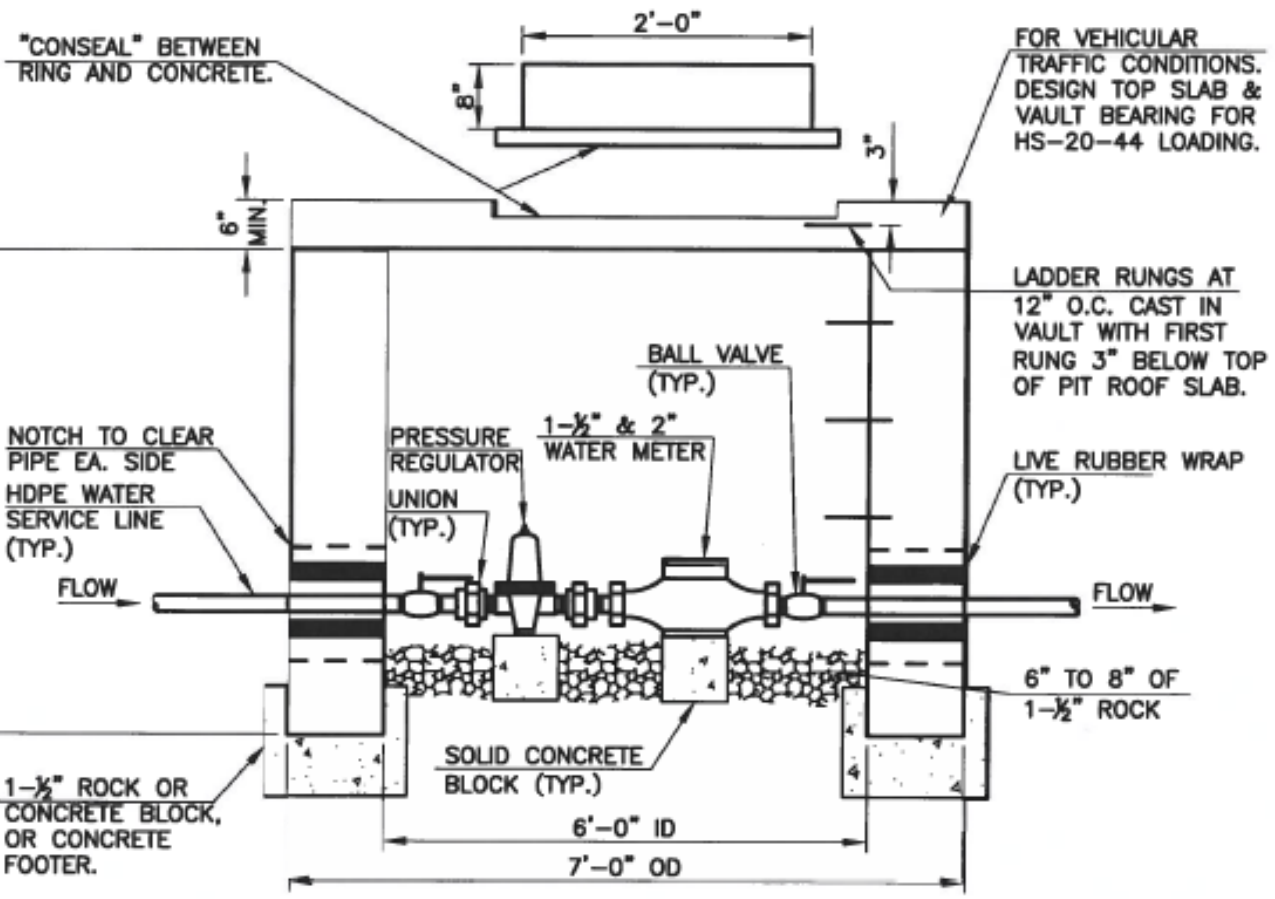
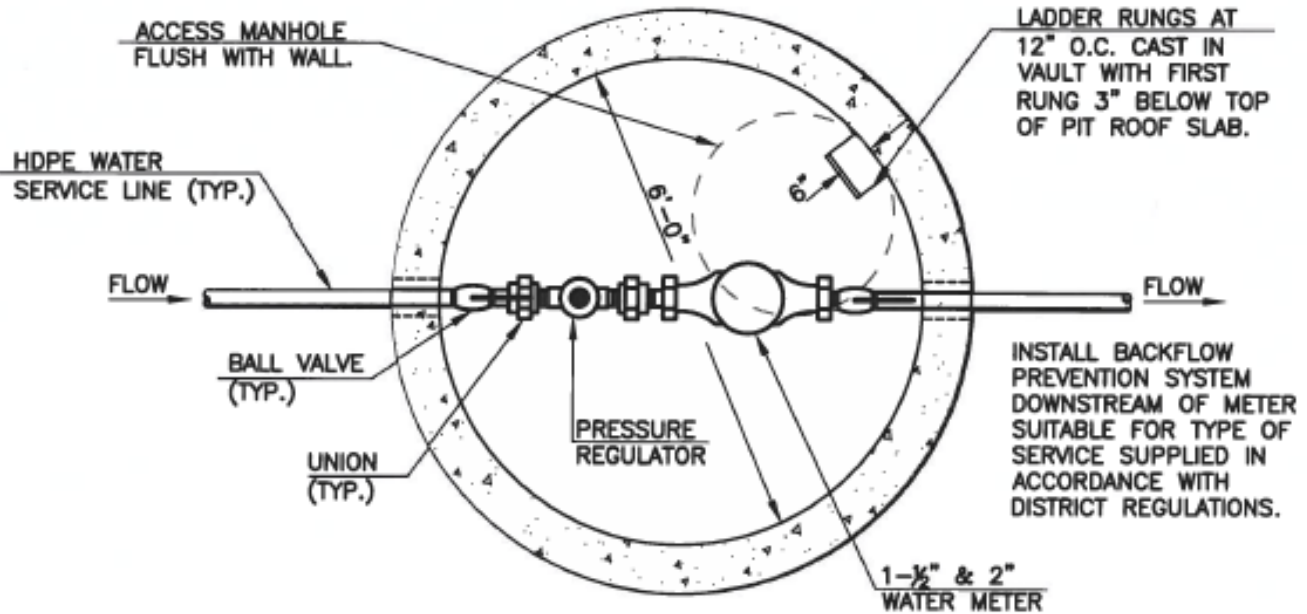

DONALA WATER &
SANITATION DISTRICT

IRRIGATION SERVICE 3/4" & 1" METER INSTALLATION			
DRAWN: RGG	REVISED: MAY 2018		
DATE: DEC. 05	REVISED:		
SCALE: NONE	REVISED:		
			W-42

G:\DONALAVISIT\SPECS\Water\Draw-42.dwg, 8.5x11, 5/2/2018, 1:47:10 PM, gc_xerox, Altalink C8035, 1:1

PART II

WASTEWATER COLLECTION SYSTEM STANDARD SPECIFICATIONS

Chapter 1 - General

- 1.01 Authority. These Specifications are promulgated by the Donala Water and Sanitation District. The interpretation, enforcement, and revision of these Specifications is hereby delegated to the Superintendent of the District.
- 1.02 Effective Date of Specifications. These Specifications shall be in effect fifteen (15) calendar days after adoption by the District board and shall supersede all former standard specifications for installation of sanitary sewer mains within the District.
- 1.03 Revisions, Amendments or Additions. These Specifications may be revised, amended or added to. Such revisions, amendments and additions shall be binding and in full force and effect when adopted in the manner set forth in Section 1.02.
- 1.04 District Control. These Specifications will apply to the installation, operation and maintenance of all wastewater collection facilities under the control of the Donala Water and Sanitation District.
- 1.05 Organization and Interpretation of Specifications. These Specifications are composed of written Standards of Engineering Practice, Material Specifications and Standard Drawings. The interpretation of any section or of differences between sections, when appropriate, shall be made by the Superintendent of the District and his/her interpretation shall be binding and controlling in its application.
- 1.06 Definitions. As used in these Specifications, or in any of the drawings where these Specifications govern, unless the context shall otherwise require, the following words defined shall have the meanings herein ascribed:
- a. Superintendent. The Superintendent of the District or his/her designated representative.
 - b. Engineer. The Engineer or consultant of the District, acting either directly or through properly authorized agents, such agents acting within the scope of the particular duties entrusted to them.
 - c. Collection System. Sewer mains, together with all appurtenant and necessary manholes, clean outs, taps, service pipes, and associated materials, property and equipment collecting sanitary sewage from individual customers.
 - d. Wastewater Main or Sanitary Main. That portion of the wastewater system which collects sewage from users to the District wastewater treatment plant, excluding service lines.

- e. Service Line. The sewage collection pipeline extending from the premises down to and including the connection to the wastewater or sanitary main.
 - f. Applicant for System Extension. Any person, association, corporation, entity, or government agency desiring sanitary sewer service for premises under their control, often a subdivider, a developer or an owner.
 - g. Main Extension. Extensions to the existing collection system network.
 - h. Contractor. In the context of these Specifications a person or persons, co-partnership or corporation employed by an applicant for the purpose of installing wastewater system extensions or replacements.
 - i. Inspector. The authorized representative of the District assigned to the project.
 - j. Standard Drawings. District Standard Drawings are a part of these Specifications.
 - k. District. The Donala Water and Sanitation District responsible for overseeing the wastewater system's operations.
- 1.07 Abbreviations. All references to documents or specifications shall be the latest edition or revision thereof:
- a. ASTM American Society for Testing and Materials
 - b. ANSI American National Standards Institute
 - c. NSF National Sanitation Foundation
 - d. OSHA Occupational Safety and Health Act
 - e. USGS United States Geological Survey
 - f. CIP Cast Iron Pipe
 - g. DIP Ductile Iron Pipe
 - h. PVC Polyvinyl Chloride-Plastic Pipe

WASTEWATER COLLECTION SYSTEM STANDARD SPECIFICATIONS

Chapter 2 - Design Provisions

- 2.01 Planning Considerations. The land use and population densities approved for the District shall be used to determine wastewater facility design parameters. Where approved master plans do not exist, the following criteria shall be used unless specific approval for other criteria has been given by the District.
- a. Design Period: The sewer systems shall be designed for the estimated ultimate tributary population. The tributary areas shall be studied to determine the area for each projected land use.
 - b. Population densities including public use lands:
 - (1) Single-family units at 3.2 persons per unit.
 - (2) Multi-family and condominiums at 2.5 persons per unit.
 - (3) Four (4) single-family units per acre.
 - (4) Sixteen (16) multi-family cluster housing or condominiums per acre.
 - c. Per capita flows: Sewer systems shall be designed on the basis of not less than the following unless other values are specifically authorized by the District:
 - (1) One hundred (100) gallons per person per day.
 - (2) Three hundred (300) gallons per capita per day peak flow for submains and laterals.
 - (3) Two hundred fifty (250) gallons per capita per day peak flow for main trunk, interceptor or outfall sewers.
 - (4) Infiltration of 100 gallons per day per inch of diameter per mile per manhole run for new systems. New system installations which will service a portion of the existing collection system will require an infiltration/bleeding allowance as established by the District.
 - (5) Commercial land uses at 1400 gallons per acre per day with a peak factor of 2.
 - (6) Industrial land uses at 1600 gallons per acre per day with a peak factor of 3.
 - (7) Public use, park and open space at 1000 gallons per day with a peak factor of 2.
- 2.02 Minimum Size. No public sewer shall be less than 8 inches in diameter. No building sewer shall be less than 4 inches in diameter.
- 2.03 Minimum Depth. In general, sewers shall be designed deep enough to drain basements and to prevent freezing. No public mains shall be less than 5 feet deep measured from the top of pipe unless special protection is required. Special protection shall consist of:

- (a) Less than 5 feet but more than 3 feet of cover requires ductile iron pipe or SDR 26 PVC with reinforced concrete arch.
- (b) SDR 35 PVC pipe material may be used where the depth of cover is more than 5 feet, except as otherwise provided for at locations where depth of cover exceeds 16 feet.
- (c) Less than 3 feet of cover requires ductile iron or cast iron with reinforced concrete encasement only after consultation with the District.

No building sewer shall be less than 5 feet deep in traffic areas without similar special protection listed above except that concrete driveways may be substituted for protection of service lines.

- 2.04 Minimum Slopes. All sewers shall be designed to transport average sewage flows at mean velocities of 2 feet per second based on a Manning's roughness factor of 0.013. The slope between manholes shall be uniform. In no case shall the slope be less than the following for sewer mains and services:

MINIMUM GRADE TABLE

Services

<u>Pipe Diameter</u>	<u>Slope</u>
4 Inches	2% or 1/4 inch per foot
4 Inches	Ductile iron or cast iron pipe - 1% or 1/8 inch per foot
6 Inches	1% or 1/8 inch per foot

Mains and Services

<u>Pipe Diameter</u>	<u>Slope</u>
8 Inches	.40%
10 Inches	.35%
12 Inches	.26%
15 Inches	.20%
18 Inches	.15%

- 2.05 High Velocity Protection. In the case of sewers where the slopes are such that over 15 percent grades are attained, special provisions as determined by the District shall be made to prevent excessive erosion of material surfaces or displacement by impact. Such high velocity protection shall be shown on detail drawings and approved by the District on a case-by-case basis.
- 2.06 Alignment. Standard location for sewers, unless some major interference prevents, is along the centerline of the street, easement or right-of-way. In streets less than 36 feet wide and alleys, the standard location shall be parallel to but removed 2 feet from the center line. Manholes shall be located so as to prevent storm water entrance. Proposed

sewer lines which may conflict with the placement of other underground facilities will require prior approval of the sewer placement location by the controlling agencies whose facilities are affected. Locations other than those specified will require specific approval of the District.

2.07 Pipe Alignment in Manholes

- a. Intersections. All pipes shall have free discharge into the collection system. Where possible, the flow line of the intersecting pipe shall be the spring line (horizontal center of pipeline) of the collection sewer. All manhole inverts shall be designed with a 0.1 foot drop except for changes in alignment in excess of 30° shall have a 0.3 foot drop in the invert through the manhole. Changes in direction at intersections shall not be greater than 90°.

When the intersecting pipe is smaller in diameter than the pipe exiting the manhole, the crown or inside-top of the intersecting pipe shall match the crown or inside-top of the main pipe entering the manhole. In no case shall the difference in elevation between the flowline of the pipe exiting the manhole and the flowline of the intersecting sewer be less than 0.3 feet.

- b. Increasing Size. When sewers are increased in size with no intersecting sewers, the invert of the larger sewer shall be lowered sufficiently to maintain the same energy gradient.

- 2.08 Manhole Location. Manholes shall be installed at the end of each line, at all pipeline intersections, changes in grade, size, alignment and at distances not greater than 400 feet. Manholes must be located to allow unassisted and unrestricted access by District maintenance vehicles. Lines and manholes located in areas where access, in the opinion of the District, is not possible, will not be approved for construction.

2.09 Manhole Details

- a. Manhole Sizes. The inside diameter of the manhole shall not be less than 5 feet on lines 8 inches through 36 inches in diameter; not less than 6 feet on lines in excess of 36 inches in diameter for standard design manholes (see Drawing No. 3 for standard manhole design).
- b. Drop Manholes. External drop manholes will be permitted only in extreme and special conditions where approval has been granted by the District. As a general criteria, a minimum difference in elevation of 4 feet between the inlet and outlet is required before considering use of external drop manhole design. The external drop sections must be totally encased in reinforced concrete and placed on an adequate foundation (see Drawing No. 2 for standard drop manhole design).
- c. Manhole Channels. The flow channel shall be made to conform to the slope and shape of the sewer pipe entering and exiting the manhole. The channel shall be formed from cast-in-place concrete to a cross-section matching the circular pipes. The channel shall be constructed with vertical walls from a point one-half the pipe diameter above the channel flowline as shown in the standard drawings. At intersections with

other lines, channels shall be formed with a curve to minimize turbulence. The flow channel shall be constructed to have a depth equal to the pipe diameter. Refer to Drawing Nos. 2 & 3.

- d. Manhole Gaskets. The pipes entering and exiting the manhole shall be equipped with a manhole gasket placed around the pipe and cast in the base. If a precast base is used, a watertight seal shall be obtained by use of a premanufactured rubber gasket in the precast base section equal to a Kor-N-Seal boot.
- e. Rings and Covers. The ring and cover shall be constructed of cast iron for traffic bearing conditions and cast aluminum or cast iron for non-traffic bearing conditions. All manholes located outside of dedicated street or alley rights-of-way will be designed and constructed with a locking type cover and the ring bolted to the concrete cone. Grade adjustment rings or blocks between the ring and cover and the concrete cone cap shall not exceed 6 inches.
- f. Watertightness. Precast concrete manhole joints shall be made watertight. Manholes of brick or segmented block shall not be used in the sanitary sewer system.
 - (1) Each precast manhole segment shall be joined with a rubber "O" ring, Ram-Nek, Con-Seal or similar approved material.
 - (2) All interior concrete manhole surfaces above the flow channel shall receive a 3/8" to 1/2" thick coating of cement grout. Concrete surfaces shall be thoroughly wetted and damp prior to the application of cement grout. Liquid membrane curing compound shall be applied to the finished cement grout surface to facilitate proper curing. Where exterior cement grouting is required, it shall be applied prior to the application of dampproofing material and the liquid membrane curing compound shall be deleted. Exterior cement grout shall be film cured utilizing polyethylene sheets.
 - (3) All exterior concrete manhole surfaces shall be coated with coal tar dampproofing material. Where ground water is present or, in the opinion of the District, groundwater could be present, all exterior concrete manhole surfaces shall be coated with a coal tar epoxy.
 - (4) All exterior manhole joints shall be wrapped with 12" wide elastomeric joint wrap.
 1. Henry Company RUB'R NEK® External Concrete Joint Wrap or approved equal.
 - (5) Dampproofing materials shall be applied to clean, dry surfaces in accordance with the coating manufacturer's written instructions/recommendations and the following:
 1. Preparation
 - a. Examine surfaces to receive dampproofing to assure conditions are satisfactory for application of materials
 - b. Remove dirt, dust, sand, grit, mud, oil, grease and other foreign matter
 - c. Brush down surfaces to remove all loose scale, fins, dust, etc.
 - d. Complete surface preparation in accordance with manufacturer's recommendations
 2. Application

- a. General
 - 1) Apply in three (3) coats with high pile rollers or by spray equipment
 - a) Minimum air pressure: 90 psi
 - b) Spray apply in a fine mist
 - 2) Provide adequate forced ventilation when applying coating in enclosed spaces
 - 3) Do not use benzol or other volatile solvents for thinning coating
 - b. First coat
 - 1) Apply only when surface of concrete is dry and at a suitable temperature for adequate penetration
 - 2) Thin as recommended by manufacturer
 - 3) Apply for maximum penetration
 - 4) Absorbed by concrete within 5 to 30 minutes of application so no continuous film remains on surface
 - c. Second coat: Cover surface with 5 mil film
 - d. Third coat: Produce a high gloss 5 mil film
 - e. Cure material as recommended by manufacturer
 - f. Do not cover with backfill until installation is accepted by inspector
- g. Stub Outs from Manholes. Stub outs from manholes shall not exceed 40 feet except for lines which will be extended in the future. Whenever practical, designs to complete the manhole run shall be submitted to the District Superintendent for review to insure proper grade and alignment for future construction. Future extension of stub outs shall be of like material using the same grade and alignment.
- h. Design Features for Deep Manholes. Manholes which are more than sixteen (16) feet from the finished cover to the pipe invert shall be considered deep manholes subject to special design. The items given below shall be given special attention and subject to approval by the District.
- (1) Intermediate platforms constructed with manhole shaft offsets shall be governed by the OSHA regulations. Regardless of the application of OSHA regulations, an offset intermediate platform will be required on any manhole greater than 24-feet in depth at no more than 12-foot intervals.
 - (2) Structural integrity of precast or cast-in-place concrete structures shall be verified and certified by the responsible design professional for all manholes in excess of 16-feet in depth. Specific attention shall be given to concrete thickness, reinforcing design and concrete strength.
- 2.10 Relation to Water Mains. Sewer lines shall be located a minimum of 10 feet horizontally from existing or proposed water mains and the sewer lines shall be a minimum of 18 inches clear distance vertically below the water main. If this clear distance is not feasible, the crossing must be designed and constructed so as to protect the water main from potential cross connections and minimize the potential for structural damage to either pipeline. Minimum protection shall consist of the installation of an impervious and structural sewer as follows:

- a. Where the sewer pipe is above the water main, regardless of separation, one length of ductile iron pipe at least 18 feet long centered over the water main and jointed to the sanitary sewer pipe with a manufactured adapter specifically for such jointing shall be installed. It shall include rubber gasketed fittings with stainless steel tightening bands. The joints shall be enclosed in a concrete collar at least 6 inches thick and extending at least 6 inches either side of the joint.
- b. Where the sewer is beneath the water main but less than 18 inches clear distance vertically, the sewer pipe of any material shall be encased in reinforced concrete. Encasement shall be at least 6 inches thick and extend a distance of 10 feet on either side of the water main crossing. Reinforcing shall consist of a minimum of four No. 4 bars placed at quarter points around the pipe being encased.

The above-described protection from potential cross connections shall apply to service lines as well as sanitary sewer mains where the above described protection and special installation is required.

- c. Comply with current Colorado Department of Public Health and Environment (CDPHE) requirements.

2.11 Stream and Drainage Channel Crossings

- a. All stream and drainage channel crossings shall be ductile iron pipe encased in reinforced concrete where the installation is below the flow line of the stream or drainage channel.
- b. Crossings less than 4 feet below existing or proposed channel bottoms shall be supported by reinforced concrete caissons constructed in accordance with the approved special design.
- c. Where the pipeline crossing will be above the stream or drainage channel flow line, special approval and design will be required by the District. All details of the design shall be submitted to the District for review and approval.

2.12 Railroad and Highway Crossings

- a. All work shall be accomplished in accordance with the appropriate permit issued by the responsible agency having jurisdiction over the work.
- b. Crossings under railroads and highways shall consist of polyvinyl chloride (PVC), ductile iron or coal tar enamel lined steel pipe (carrier pipe) laid inside a steel pipe conduit (casing pipe), which is placed beneath the track or roadway. The steel conduit pipe (casing pipe) shall be jacked horizontally through the ground on substantially the grade of the sewer, with due allowance for the bells or joints of the carrier pipe. As the pipe is jacked along, the earth shall be excavated from the face and removed so that it will not be necessary to force the pipe through solid ground. Specifications for materials and installation of the railroad or highway agency shall govern.
- c. The casing pipe diameter for 16-inch and smaller carrier pipes shall be a minimum of 8

inches larger than the carrier pipe and the casing pipe diameter for larger than 16-inch diameter carrier pipe shall be a minimum of 12 inches larger than the carrier pipe.

- d. After the conduit has been completed, the carrier pipe shall be placed inside and blocked in exact position and grade with a support at least every 8 feet and behind each bell or coupling. A minimum of three blocks or other points of support shall be installed to prevent displacement by floating.
- e. Each end of the casing pipe shall then be plugged tight around the carrier pipe and inside the casing pipe. The plug may consist of an 8-inch brick wall laid up with Portland cement mortar or a prefabricated rubber boot with stainless steel tightening bands specifically for sealing casing pipe ends.

2.13 Service Lines (Building Sewers)

- a. Service lines and stub outs from main sewers shall be extended to each property at a point 5 feet inside the property line and generally 5 feet above the low lot corner.
- b. Stub outs from a sewer main may be made to an unoccupied lot provided it is part of an officially platted and recorded subdivision. Such stubs shall be extended to 5 feet inside property line and plugged with a watertight and airtight cap or plug insert. Plugging or capping shall be sufficient to perform air testing of the pipeline. Records of the depth and location of the end of the service stub shall be recorded by party responsible for construction and submitted to the District for future reference.
- c. Four-inch diameter service lines shall have a maximum length of 250 feet. A 4-inch diameter cleanout shall be installed on the service lines where the total length exceeds 100 feet and at 75 foot intervals thereafter up to a maximum of 250 feet in length. The cleanout shall have a proper waterproof cap. Place cast iron riser box over PVC cleanout with a cast iron lid, with "SEWER" cast in the lid, capable of being located by metal detection equipment. For cleanout access, a prefabricated formed wye with a riser pipe shall be installed to the finished grade.

Service lines projected to be longer than 250 feet in length shall have pipe 6 inches in diameter or as otherwise required by the District. Provisions for cleanouts shall also apply to pipelines 6 inches in diameter.

- d. No service line within the District's service area will serve more than one property or customer. Each house, building or business shall have an individual connection to the sewer main and service line from the main to the structure served.
- e. All service lines for commercial buildings or multi-family buildings shall be no less than 6-inches in diameter.
- f. Any service line requiring 3 or more bend fittings between the sewer main line and building served shall be constructed with a cleanout at intervals specified above. If 3 or more bend fittings are required in a service line with a length less than 100 feet, a cleanout shall be installed at the midpoint of that section.

2.14 Pump Station Design Parameters. Design of pump stations within the District's collection system shall be accomplished on a case by case basis. Pump stations shall not be used wherever gravity sewer service is available. Preliminary considerations and a rationale for the need of the pump station shall be reviewed in detail with the District's Superintendent prior to proceeding with preliminary and final design. As general guidelines for planning purposes, any pump station considered by the District must include, but is not necessarily limited to the following design features:

- a. Dry pit or wet well mounted pumping equipment.
- b. Multiple pumps.
- c. Standby power generation or dual source of power supply.
- d. Ventilation, heating and dehumidification equipment.
- e. Automatic controls.
- f. Remote alarm system for operating functions.

2.15 Sanitary Sewerage Plan Submittal Requirements

- a. Plans and Specifications. Three (3) copies of all plans and specifications for facilities to be installed under these rules and regulations shall be furnished to the District. One (1) copy will be returned to the applicant when approved by the District and bear evidence of such approval or comments requiring correction.
- b. Plan Content. As a minimum, the following information shall be required on all plans.
 - (1) Plan View: The plan view shall show streets, alleys, rights-of-way and utility easements with the location and size of the sewers, locations and distance between manholes, the slope and other appurtenances indicated. It is desirable for plans to show the proposed size and location of service stubs and the location of all existing or proposed underground utilities and structures located within 20 feet horizontally or vertically, of the centerline of the proposed sewer extension. (The scale is optional, however, 1"=50' is commonly used.)
 - (2) Profile View: The profile view with vertical and horizontal grids shall show the existing ground surface (dotted) and proposed surface (solid). Also, show the proposed sewer with elevations of manhole rims and inverts, the distance and grade between manholes and elevations of utility crossings.
 - (3) Detail drawings: Special detail drawings, made to scale, shall clearly show the nature of design and construction of the following:
 - (a) Special sewer appurtenances such as non-standard manholes, inverted siphons and elevated sewers.
 - (b) Special joints and utility or storm sewer crossings.
 - (c) Stream and drainage channel crossings with elevations of normal high and low water levels.
- c. Supporting Data: Submit with the plans and specifications all necessary supporting data to fully describe the proposed installation. This data shall include but not necessarily be limited to a copy of the recorded plat of the subdivision in which the

improvements are proposed to be installed and copies of dedicated rights-of-way and easements in which improvements are proposed to be installed. Submit copies of necessary permits from other governmental or private agencies having jurisdiction in the area of the proposed work.

Should a site application for a collection system extension be required by the Colorado Department of Health, the individual party responsible for construction of the facility shall also be responsible for obtaining this site approval.

- d. Upon completion of construction and prior to acceptance by the District, two (2) copies of "as-constructed" plans shall be submitted to the District for record. The two (2) copies shall be complete with all "as-constructed" information together with a certification by the party responsible for construction that all data thereon is accurate and represents actual "as-constructed" conditions. One (1) copy shall be a transparency suitable for blueprint reproduction. "As-constructed" plans shall be submitted within two weeks of completion of the sanitary sewer construction in any identifiable phase of a development. No authorization to connect to the system or discharge to the system will be allowed until the "as-constructed" documents have been received and accepted by the District.
- e. All plans, specifications and supporting documents shall be prepared by or under the direct supervision of a professional engineer registered to practice in the State of Colorado. All plans and specifications shall bear the seal and registration number and name of said registered professional engineer.
- f. All "as-constructed" plan submittals must include plan sets in AutoCAD format and a set in Portable Document Format (PDF).

2.16 Sewage System and Trench and Foundation Drains

- a. In no case shall any trench drains, foundation drain or other drainage fixture be connected to the District's system which may introduce any wastewater other than sanitary sewage into the system.
- b. All piping material incorporated into the District's sanitary sewage system shall not be white unless utilizing Schedule 40 PVC. At the time of the preparation of these specifications, the predominant pipe color is green. All trench or foundation drainage piping shall be white to preclude accidental cross-connection of the drainage systems.

WASTEWATER COLLECTION SYSTEM STANDARD SPECIFICATIONS

Chapter 3 - Pipe and Manhole Materials

3.01 PVC Pipe and Fittings (Polyvinyl Chloride)

a. Conformance

ASTM 3034; Standard Dimension Ratio (SDR) shall be maximum of 35.

b. Joints

ASTM D3212; Bell and spigot, push-on with single rubber gasket.

Jointing of dissimilar pipe materials shall be accomplished with a specially manufactured rubber connection with stainless steel tightening bands (Mission Rubber Company, Fernco or equivalent).

Solvent Cement Joints may be used for 4-inch and 6-inch pipe.

c. Length of Joints

The length of joints for flexible conduits shall not exceed 12-1/2 feet for grades less than one percent.

d. Criteria for Acceptance. Pipe which has any of the following visual defects will not be accepted.

- (1) Improperly formed pipe such that pipe intended to be straight has an ordinate, measured from the concave side of the pipe exceeding 1/16 inch per foot of length.
- (2) Pipe which is out-of-round to prohibit proper jointing.
- (3) Improperly formed bell and spigot ends or bells which are less than 1-1/2 inches in length.
- (4) Pipe which is fractured, cracked, chipped or damaged in any manner.
- (5) Pipe that has been damaged during shipment or handling.
- (6) Pipe or fittings not properly marked as required by the following specifications.

e. Marking of Material. The following shall be clearly shown on the exterior of the pipe:

- (1) Manufacturer's name.
- (2) Appropriate ASTM designation.

- (3) Appropriate SDR number of 4-inch and 6-inch pipe.
 - (4) Homemark.
- f. Material Handling and Storage. Avoid damage to pipe from impact, bending, compression or abrasion during handling and storage.

Store pipe on flat surface which provides even support for the pipe barrel with bell end overhanging. Do not stack pipe higher than 5 feet. Do not store pipe and fittings in direct sunlight for extended periods (greater than two to three weeks). Any discoloration of the pipe material shall be evidence of ultraviolet damage and shall be reason for rejection and the removal from the project.

Ship rubber gaskets in cartons and store in a clean area away from grease, oil, ozone producing electric motors, heat and the direct rays of the sun.

Use only nylon protected sling to handle pipe. The use of hooks, bare cables or chains will not be permitted.

For pipe slopes less than one percent, the maximum pipe joint length shall be 13 feet.

- g. All PVC pipe installed in the District's sanitary sewer system including mains and services shall be non-white in color. White sewer pipe shall not be acceptable as trench and foundation drain piping used in the District shall be white to better assure that there is no accidental connection between the two separate drainage systems.
- h. PVC pipe shall not be installed at depths in excess of fourteen (14) feet without specific approval of the District.

3.02 Ductile Iron Pipe

a. Conformance

ANSI 21.51; Thickness Class 50, unless otherwise required for internal or external loading.

Fittings shall conform to ANSI 21.10 for flanged, mechanical joints and push-on joints (AWWA C110 or C153).

b. Joints

- (1) Mechanical Joint: ANSI A21.11
- (2) Push-On: ANSI A21.11
- (3) Flanged: ANSI B16.1, 125 lb. drilling
- (4) Rubber Gaskets: AWWA C111 (ANSI A21.11)

c. Protective Coatings

- (1) Exterior Coating: Manufacturer's standard coating approximately 1 mil thick.
- (2) Interior Lining:

- a.) Type: Ceramic Epoxy
- b.) Thickness: 40 mils DFT
- c.) Design Basis: U.S. Pipe Protecto 401 or equivalent
- (3) Polyethylene Wrapping. All ductile iron pipe shall be installed with an 8 mil thick polyethylene wrapping.

d. Criteria for Acceptance. In addition to any deficiencies covered by the reference specifications above, any of the following visual defects will not be accepted.

- (1) Improperly formed pipe such that pipe intended to be straight has an ordinate, measured from the concave side of the pipe exceeding 1/16 inch per foot of length.
- (2) Pipe which is out-of-round to prohibit proper jointing.
- (3) Pipe which is fractured, cracked, chipped or damaged in any manner.
- (4) Pipe that has been damaged during shipment or handling.
- (5) Pipe which has lining which is fractured, cracked, chipped or damaged in any manner and would not provide satisfactory service under the conditions intended.

e. Marking of Material & Certification of Manufacturer. All materials shall be marked with the name of the manufacturer of origin. Manufacturer will provide a certification to the District that all products supplied to the project site are in conformance with these specifications.

f. Material Handling and Storage. Handle pipe fittings and accessories using lifting hoist or skidding to avoid shock or damage. Do not drop such materials. Do not allow pipe unloaded on skidways to be skidded or rolled into pipe previously unloaded. Protect the pipe coatings and linings from damage during delivery and handling.

3.03 Manholes. Except as otherwise specifically approved by the District, manholes shall be precast concrete and manufactured in accordance with the referenced specifications.

a. Conformance

Precast concrete in conformance with ASTM C478.

b. Size of Manholes

<u>Size of Sewer Main</u>	<u>Inside Diameter of Manhole</u>
Up to 36 inches	5'
42 inches and above	6'

c. Cement

All cement used in manhole construction shall be Type II or Type IILA. All concrete shall have a 28-day compressive strength of at least 3,000 pounds per square inch (psi).

Rubber gasketed joints for pre-cast manhole sections shall be an R-4 joint and designed in accordance with ASTM C443.

Manhole joints may be joined with flexible plastic/rubber gaskets constructed of Ram-Nek, Rubber-Nek, Con-Seal or equivalent.

3.04 Cast-in-Place Concrete. All cast in place concrete utilized in sanitary sewer construction shall have a minimum compressive strength of 3000 psi at 28 days unless specifically required otherwise by the project.

a. Aggregates

Conform to ASTM C33, maximum size shall be 3/4 inch nominal diameter.

b. Cements

Portland Cement in accordance with ASTM C150, Type II or IILA will be used for all concrete.

c. Admixtures

Air entraining admixtures will be permitted in conformance to ASTM C260. Maximum entrained air shall be 6.5% and minimum shall be 5.0%. Water reducing and retarding admixtures may be utilized with the specific approval of the District. Such admixtures shall be in conformance with ASTM C493. Flyash or calcium chloride are not permitted for use.

d. Water/Cement Ratio

Maximum water cement ratio shall be 0.42.

e. Slump

Maintain within the following limits:

1" minimum, 3" maximum for all concrete to be incorporated in sanitary sewerage facilities.

3.05 Castings

a. Cast Iron

(1) Conformance: ASTM A48

(2) Applicable Items: Manhole rings and covers with non-slip surface with

"SEWER" cast in the cover. Combined weight will not be less than 300 pounds. Ring shall be a minimum of 4 inches in height.

3.06 Steps. All manholes shall have steps at a maximum of 16 inches vertical spacing unless otherwise specifically directed by the District.

a. Material: Plastic (co-polymer polypropylene) with 1/2" diameter Grade 60 steel reinforcement as manufactured by M.A. Industries, Inc.

b. Design Equipment: PS-2-PF-DF Manhole Step with non-skid grooves and safety nosings or drop front design.

c. Conformance: ASTM C-478-02, Section 13 Manhole Steps and Ladders

3.07 Cement Mortar

Conformance: ASTM A270, Type M.

3.08 Cement Grout

a. Cement

Portland Cement in accordance with ASTM C150, Type II or II LA

b. Sand

Clean, well-graded, natural sand in accordance with ASTM C33

c. Proportioning

One part Portland Cement, 2½ parts sand, by weight, with minimum water required for placement and hydration

3.09 Non-Shrink Grout

Approved commercial factory mix product made especially for intended use. Utilize non-metallic chemical grout for non-shrink applications.

3.10 Dampproofing Material

Coal tar solution type coating; Tnemec "47-461 Foundation Coating," International "Intertuf 100," Carbolite "Bitumastic Super Service Black" or similar approved material

WASTEWATER COLLECTION SYSTEM STANDARD SPECIFICATIONS

Chapter 4 - Pipe Installation

4.01 Subgrade Preparation

See Part III of these regulations.

4.02 Pipe Laying

- a. Begin pipe laying at the lowest point, unless directed otherwise by the District, and install the pipe with the spigot ends pointing in the direction of flow.
- b. Unless required or directed otherwise by the District, lay all pipe straight between changes in alignment and at uniform grade between changes in grade or slope.
- c. As each length of pipe is placed in the trench, the joint shall be completed in accordance with the pipe manufacturer's recommendations and the pipe shall be brought to the correct line and grade. The offset at the invert shall be less than 1% of the inside pipe diameter.
- d. The length of joints for curvilinear sewer shall be determined by the radius using joint deflection not exceeding the pipe manufacturer's recommendations. Three degree couplings can be used with authorization from the District. e. Secure the pipe in place with Class B bedding material tamped under and around the pipe. Do not walk on small diameter conduit or otherwise disturb any conduit after jointing has been completed.
- f. All foreign matter or soil shall be removed from the inside of the pipe before it is lowered into its position in the trench and shall be kept clean at all times during and after laying. All openings along the line of the sewer shall be securely closed and during suspension of work at any time, suitable pipe plugs or closures shall be placed to prevent water, soil or other materials from entering the pipeline.

4.03 Fittings, Couplings, Wyes and Saddles

- a. Fittings, couplings, wyes and saddles shall be the same material as the pipeline or as specifically manufactured for a particular installation.
- b. Jointing of dissimilar materials shall be permitted only with approval of the District representative. Jointing of such dissimilar materials shall be through the use of fittings, couplings, wyes, saddles, adapters or adhesives specifically manufactured for such transitions.

4.04 Service Lines

- a. Prepare subgrade in accordance with Part III of these regulations.
- b. Connect all service lines to mains with a tee or tee saddle in the top one-half of the sewer main. Connections made in the lower half or at mid-point of the main shall have prior approval of the District and may require the installation of a backflow prevention device.
- c. Connection of service lines to mains
 - 1) Tee saddles with rubber gaskets to be placed between the saddle and the main line of pipe, secured in place with stainless steel bands are required.
 - 2) Connection to the main line piping shall be made by cutting a hole using the appropriate hole template, tapping machine or hole saw no more than ¼-inch larger in diameter than the template outline.
 - 3) A 1/8 or 1/16 bend shall be used from the tee fitting to attain the desired grade and slope for the service line piping.
 - 4) The tee saddle shall be furnished with an integral rubber gasketed bell.
 - 5) All service line piping between the main line and the property line of the property to be serviced shall be pipe in accordance with these specifications with intergal rubber gasketed pushon joints.
 - 6) In general, no change in horizontal alignment will be permitted between the connection at the main line and the property line of the property being serviced.
- d. Service line connections shall be separated by a minimum of 3 feet measured center to center along the main.
- e. Plug all service line stubs with water and air tight cap or plug unless the service line will be immediately connected to a building sewer.

Where new street construction is proposed immediately following construction of sanitary sewer facilities, extend the service line to 5 feet inside the property line, install the appropriate plug and mark with a vertical wood marker extending above the surface and having dimensions of 2" x 4" minimum.

- f. The Contractor and/or Developer shall provide complete as-built information on each service line connection installed within his/her work. As a minimum this information shall include the location of the connection to the main referenced to the nearest manhole or other permanent improvement, the location of the end of the service line stub, the direction of the service line as it relates to surrounding permanent surface improvements, the size, the material of construction and the date and name of the installer. All such information shall be provided to the District's representatives for incorporation into the District's permanent records.
- g. Connection of service lines and service line construction shall be accomplished by experienced, qualified personnel with adequate equipment. The District's representative shall have authority to reject work and may not permit work to be accomplished unless done by qualified personnel.

4.05 Manholes

- a. Cast-in-place concrete manhole base
 - 1) Prepare the subgrade and excavation in accordance with the specifications.
 - 2) Provide reinforcing, grade 60 reinforcing bar, No. 4 at 12-inches on center each way for manholes 12-feet or less in depth. Place steel at 8-inches on center each way on manholes in excess of 12 feet in depth.
 - 3) Place concrete against undistributed soil to the depth, thickness and other dimensions shown on detailed drawings.
 - 4) Finish and cure the cast-in-place concrete for a minimum period of 24 hours prior to placing precast manhole sections on the cast-in-place base.
 - 5) Maintain ground water below the bottom of the cast-in-place concrete for a minimum period of 24 hours following placement of concrete by maintaining pumping equipment in operation below the subgrade of the manhole base.
 - 6) Concrete shall contain a minimum of 564 lbs of Type 2 portland cement per cubic yard (6 sacks mix), be placed with a maximum slump of 2 inches with maximum size coarse aggregate of $\frac{3}{4}$ -inch (ASTM C33).
- b. Provide segmental precast concrete barrel sections a maximum of 4 feet in length with preformed flexible gasket material between each barrel section as jointing material or install rubber gaskets in precast R-4 joint grooves per manufacturer's recommendations.
- c. Provide dampproofing of all manhole joints.
 - 1) Each precast manhole segment shall be joined with a rubber "O" ring, Ram-Nek, Con-Seal or similar approved material.
 - 2) Provide exterior dampproofing consisting of 12" wide elastomeric joint wrap; Henry Company RUB'R NEK® External Concrete Joint Wrap or approved equal.
 - 3) When ground water is present or potentially present in the opinion of the District representatives, an application of cold tar epoxy dampproofing material shall be applied to the completed manhole structure after installation of cement grout and prior to backfilling. During construction of all dampproofing measures ground water shall be maintained below the subgrade elevation in the manhole excavation during the time sufficient for all materials to properly cure, no less than 24 hours.
- d. Provide one, one (1) foot high barrel section beneath a reducing ring or cone cap to bring the manhole ring and cover to within 6 inches of desired grade.
- e. Provide precast concrete 2-inch-high grade adjustment rings to bring the ring and cover to desired grade. A maximum of three grade adjustment rings are permitted. A maximum dimension of 2 feet shall be permitted between the manhole ring and the top manhole step.
- f. Where the manhole base is constructed from cast-in-place concrete, the sewer pipes entering the base shall be cut to length to match the inside of the manhole barrel and set to grade. Manhole gaskets shall be placed over the pipe and centered between the end of the pipe and the outside of the cast-in-place base. The cast-in-place base

shall then be constructed to the lines and grades required by the District's standard specifications and the accepted plans. Sewer pipe shall not be laid through the manhole base and the concrete base and/or invert placed around the pipe.

Where preformed rubber "boots" such as Kor-N-Seal boots are used in precast manhole bases, manhole gaskets on the pipe are not required.

- g. Where intersecting pipelines or pipelines requiring deflections at manholes require that the invert of the manhole be shaped to match the pipe cross sections, such construction shall be accomplished in accordance with the detail drawings of these specifications. Form the flow line configuration of intersecting pipes to allow for free uninterrupted flow of sanitary sewage through and out of the manhole. All channel inverts shall be finished smooth by steel troweling. All inverts shall be placed and finished with a single pour of cast-in-place concrete. Placement of grout and/or other material to repair and/or reshape the manhole invert shall not be permitted unless specifically approved by the District's representative.
- h. Cast-in-place bases for manholes shall be constructed in a manner to provide for a smooth level surface on which vertical barrel sections shall be placed. Completely watertight joints shall be made utilizing preformed flexible gasket material or a precast concrete base section may be utilized. The manhole shall be constructed such that no single section varies from true vertical by more than two percent of the section length.
- i. All manholes constructed in the District shall have the ring and cover elevations set at final street grades or at a point not more than 6 inches above the existing ground in non-traffic areas unless directed otherwise by the District. The Developer/Contractor shall be responsible for adjusting the manhole rings and covers to the final elevations.
- j. In areas where street paving will be placed, the manhole ring adjustment shall be accomplished in a two-step process prior to placement of pavement. The manhole ring shall be constructed 0.5 feet below finished pavement surface elevation. Pavement shall then be placed in accordance with the applicable rules, regulations and specifications. Following completion of paving, the sanitary sewer manhole rings will be raised by the Developer/Contractor to finished grade in accordance with the specifications of the District.
- k. The ring shall be adjusted with precast concrete rings a maximum of 0.5 feet in height. Cement grout shall be placed to adjust the ring to conform to the surface. A concrete collar shall be placed around the adjusting rings and the ring of the manhole up to a point 2 inches below finished grade. Paving material shall then be placed over the concrete and match the surrounding pavement surface. Tack coat material shall be placed between new and existing asphaltic concrete surfaces, the manhole casting and the concrete collar.

WASTEWATER COLLECTION SYSTEM STANDARD SPECIFICATIONS

Chapter 5 - Testing of Pipelines and Appurtenances

5.01 Infiltration. Use where ground water may be above the pipeline invert.

- a. Infiltration tests shall be conducted on each segment of the sanitary sewer system where it could be anticipated that ground water may rise above the flow line of the pipeline. Tests shall be conducted by placing an approved calibrated V-notch weir in the line just above the next lower manhole and plugging the line just above the next higher manhole. Sufficient time will be allowed to permit the water level behind the weir to stabilize before reading. Any foreign material hanging to the weir will be dislodged before reading. Successive readings shall be taken until consistent results are obtained.
- b. The maximum allowable infiltration shall be 100 gallons per day per inch of pipe diameter per mile of pipe.
- c. Each segment of pipeline between manholes or other major appurtenances must satisfy and pass the infiltration tests.
- d. Should it be determined that the infiltration rate is in excess of that permitted by these regulations, any repair and/or replacement of pipelines, manholes or other appurtenances shall be at the Contractor's and/or Developer's expense. Satisfactory repair and replacement shall be accomplished prior to the consideration of acceptance of any facility by the District.
- e. The Contractor and/or Developer will furnish all labor, equipment and materials required to accomplish such testing.

5.02 Air Test. All segments of sanitary sewer mains shall be subjected to an air pressure test. Where ground water levels are above the conduit, increase the test pressures given below to compensate for the pressure on the conduit from the ground water.

- a. The Contractor may conduct an initial air test of the sewer main line after compaction of the backfill but prior to the installation of any service lines. Such tests shall be considered for the Contractor's convenience in quality control of the project construction. Final consideration for acceptance of the sanitary sewer by the District shall be based on satisfactory completion of testing with all service line stubs installed.
- b. Preparation of Tests: Flush and clean the sewer line prior to testing in order to wet the pipe surfaces and produce more consistent results. Plug and brace all openings in the main sewer line and the upper end of any connections. Check all pipe plugs with a soap solution to detect any air leakage. If leaks are found, release the air pressure, eliminate the leaks and start the test procedure over again.

- c. Procedure of Test: Add air until the internal pressure of the sewer line is raised to approximately 4.0 psi gage at which time the flow of air shall be reduced and the pressure maintained between 3.5 and 4.5 psi gage for a sufficient time to allow the air temperature to come to equilibrium with the temperature of the pipe.
- d. After the temperature has stabilized the pressure shall be permitted to drop to 3.5 psi gage at which time a stop watch or a sweep second hand watch shall be used to determine the time lapse required for the air pressure to drop to 3.0 psi gage.
- e. If the time lapse is less than that shown in the table, the Contractor shall make the necessary corrections to reduce the leakage to acceptable limits.
- f. If the time lapse exceeds that shown in the table, the pipe shall be presumed to be within acceptable limits for leakage.

Pipe Dia.(in.)	Minimum Time (min:sec)	Length For Minimum Time (ft.)	Time for Longer Length (L, ft.) (sec)	LENGTH (ft.)			
				100	200	300	400
4	1:53	597	0.190L	1:53	1:53	1:53	1:53
6	2:50	398	0.427L	2:50	2:50	2:50	2:51
8	3:47	298	0.760L	3:47	3:47	3:48	5:04
10	4:43	239	1.187L	4:43	4:43	5:56	7:54
12	5:40	199	1.709L	5:40	5:42	8:33	11:24
15	7:05	159	2.671L	7:05	8:54	13:21	17:48
18	8:30	133	3.846L	8:30	12:49	19:14	25:38
21	9:55	114	5.235L	9:55	17:27	26:11	34:54
24	11:20	99	6.837L	11:24	22:48	34:11	45:35
27	12:45	88	8.653L	14:25	28:51	43:16	57:42

Safety: The air test may be dangerous if proper precautions are not taken. All plugs must be sufficiently braced to prevent blowouts and the pipeline must be completely vented before attempting to remove the plugs.

As a safety precaution, pressurizing equipment shall be provided with a regulator setting of 5 psi to avoid overpressurizing and damaging an otherwise acceptable line.

5.03 Alignment Testing

- a. Each section of pipeline on a linear alignment between manholes will be subject to testing by lamping by the District's representatives to determine where proper alignment has been accomplished and whether any displacement of the pipe has occurred during construction.

The Contractor and/or Developer shall provide suitable assistance to the District's

representative in accomplishing this work. The Contractor and/or Developer shall be responsible for repairing any alignment, displaced pipe or other defects discovered during this testing in accordance with these specifications.

- b. For pipelines installed at grades less than 1%, a minimum of 90% of the full pipe cross section shall be visible at the opposite end of the segment being observed.
- c. For pipelines installed at grades greater than 1%, a minimum of 75% of the full pipe cross section at the opposite end of the segment shall be observed.

- d. The determination of the acceptability of the pipeline alignment by lapping shall rest solely with the District's representative and his decision shall be final.
- e. Pipelines not meeting the requirements of the alignment tests shall be completely excavated, removed and relaid on prepared bedding material, backfilled and compacted in accordance with these specifications and then subjected to infiltration, air pressure and alignment testing.

5.04 Deflection Tests

- a. Proper construction in accordance with these specifications and the manufacturer's recommendations should result in a vertical deflection of the pipe less than 5% of the internal diameter. At the option of the District, the Contractor and/or Developer may be required to perform testing to determine conformance with this requirement.
- b. Should the District determine that deflection testing is required, the Contractor and/or Developer shall provide all necessary equipment, labor and other facilities. Data supplied by the pipe manufacturer's representative for dimensional quality shall be utilized.
- c. Should the vertical deflection of the pipe be found to exceed 5% of the internal diameter, the Contractor will remove the pipe, install proper bedding, replace the pipeline material and properly place and compact all backfill material in accordance with these specifications. Any areas removed and replaced shall be subject to infiltration, air pressure and alignment testing.

5.05 Internal Video Inspection

- a. All sewer main construction in the District shall be inspected with internal video camera and recording equipment.
 - 1) Coordination with the District shall be required as to cleaning and/or flushing prior to any internal video inspection.
- b. All costs of the internal video inspection shall be borne by the Contractor and/or Developer.
- c. The individual and/or company and permanent video tape recording shall be subject to the acceptance and approval of the District.

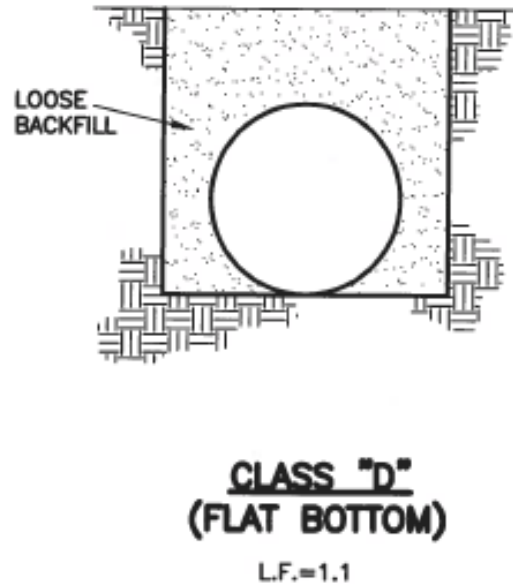
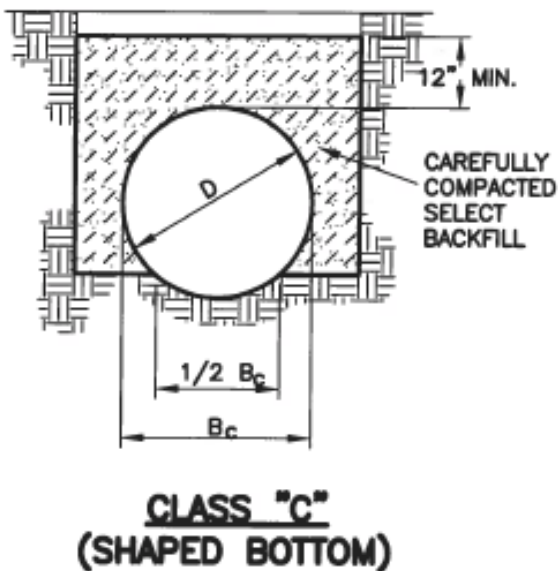
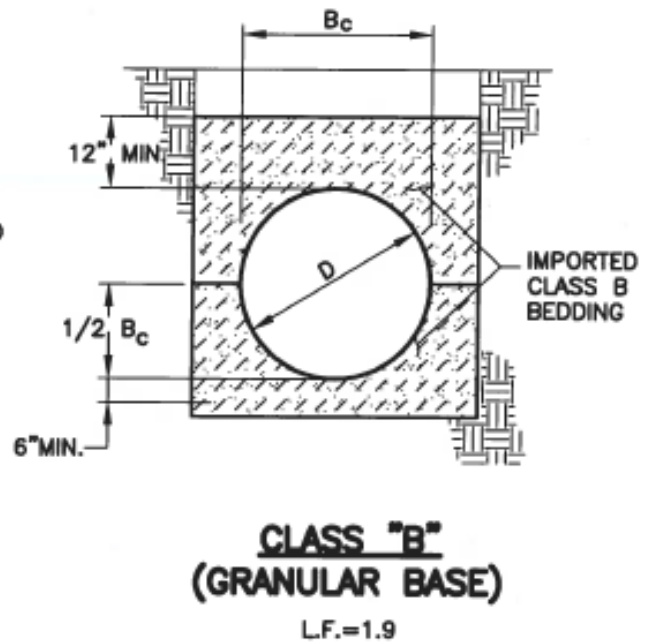
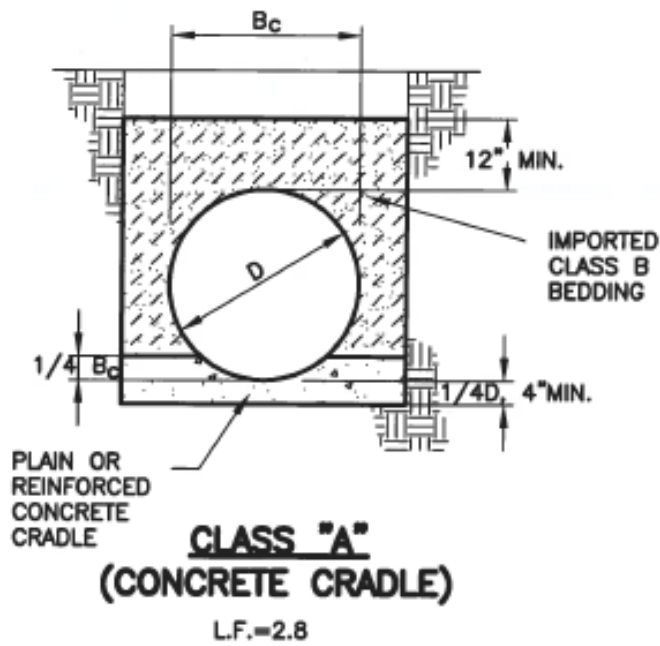

NOTES:

1. FOR ROCK OR OTHER INCOMPRESSIBLE MATERIALS, THE TRENCH SHALL BE OVEREXCAVATED A MINIMUM OF 6" AND REFILLED WITH GRANULAR BEDDING MATERIAL AS DEFINED BY CLASS "B" BEDDING.
2. L.F. = LOADFACTOR
3. CLASS "D" BEDDING WILL NOT BE ACCEPTABLE UNDER ANY CONDITION.
4. MINIMUM DENSITY FOR CAREFULLY COMPACTED SELECT BACKFILL SHALL BE 95% OF STD. PROCTOR DENSITY OR AS SPECIFIED FOR THE TRENCH BACKFILL, WHICHEVER IS GREATER.



DONALA WATER & SANITATION DISTRICT

PIPE BEDDING

DRAWN: GSM	REVISED: MAY 2018
DATE: JAN. 04	REVISED:
SCALE: NONE	REVISED:

WW-1

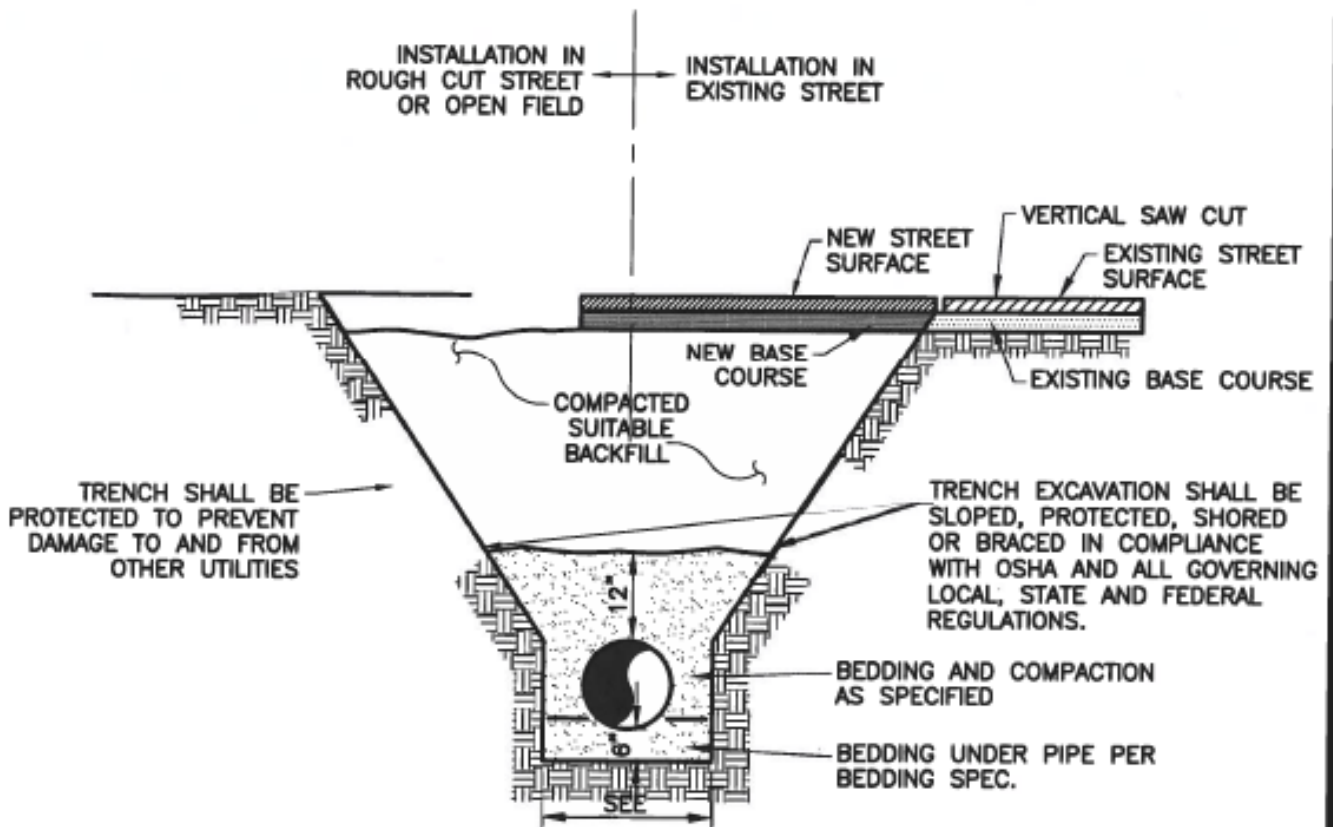

TABLE BELOW

BOTTOM OF TRENCH WIDTH		
PIPE DIAMETER	MINIMUM WIDTH	MAXIMUM WIDTH
4"	1'-5"	3'-9"
6"	1'-7"	3'-11"
8"	1'-9"	4'-1"
12"	2'-1"	4'-5"
15"	2'-6"	4'-9"
18"	2'-10"	5'-2"
24"	3'-2"	5'-6"

ALL PIPE EMBEDMENT SHALL BE IMPORTED CLASS B BEDDING UNLESS OTHERWISE DIRECTED.

AN OVER EXCAVATED TRENCH SHALL BE REFILLED AND THOROUGHLY COMPACTED UNDER THE DIRECTION OF THE FOUNTAIN SANITATION DISTRICT.

UNDER NO CIRCUMSTANCES WILL PIPE BE LAID IN A PROPOSED FILL AREA PRIOR TO IT BEING COMPLETELY FILLED. THE FILL WILL BE PLACED FIRST TO PROPOSED GRADE AND COMPACTED AS REQUIRED. A TRENCH THEN WILL BE EXCAVATED AND THE PIPE INSTALLED IN THE USUAL MANNER.



DONALA WATER & SANITATION DISTRICT

TYPICAL TRENCH CROSS SECTION

DRAWN: GSM
 DATE: JAN 2004
 SCALE: NONE

REVISED:
 REVISED:
 REVISED:

WW-2

1. MANHOLE BARREL
MINIMUM DIAMETER
SHALL CONFORM TO
TABLE.

PIPE I.D.	MANHOLE I.D.
8" TO 30"	5'-0"
36" TO 54"	6'-0"
60" & LARGER	SPECIAL DESIGN

2. SHAPING FOR SMOOTH
MANHOLE INVERTS MUST
BE DONE BY
FORMING/SHAPING
CONCRETE BASE.

3. PRECAST SECTIONS TO
CONFORM TO ASTM C-478.

4. STUB-OUTS SHALL
EXTEND A MINIMUM OF 6'
PAST MANHOLE O.D. AND
BE SATISFACTORILY
PLUGGED.

5. CONCRETE MANHOLES
MAY BE POURED IN PLACE
ONLY WITH PRIOR DESIGN
AND INSPECTION
APPROVAL.

6. ALL MORTAR GROUT
SHALL BE MIXED WITH
TYPE V CEMENT.

7. APPLY COAL TAR EPOXY
DAMP-PROOFING TO ALL
EXTERIOR CONCRETE
SURFACES. APPLY COAL
TAR EPOXY IF MANHOLE IS
PLACED WHERE GROUND
WATER IS PRESENT.

8. CENTER REINF. IN BASE
POUR BELOW PIPE O.D. AT
FLOWLINE.

9. WHERE GROUND WATER
IS PRESENT OR COULD
BECOME PRESENT DURING
THE LIFETIME OF THE
STRUCTURE, ALL EXTERIOR
JOINTS SHALL RECEIVE
BUTYL RUBBER JOINT
WRAP. REFER TO
SPECIFICATIONS.

10. 12" WIDE EXTERIOR
JOINT WRAP SHALL BE
INSTALLED AT ALL JOINTS
ON MANHOLE; HENRY CO.
RUB'R NEK® JOINT WRAP
OR EQUAL.

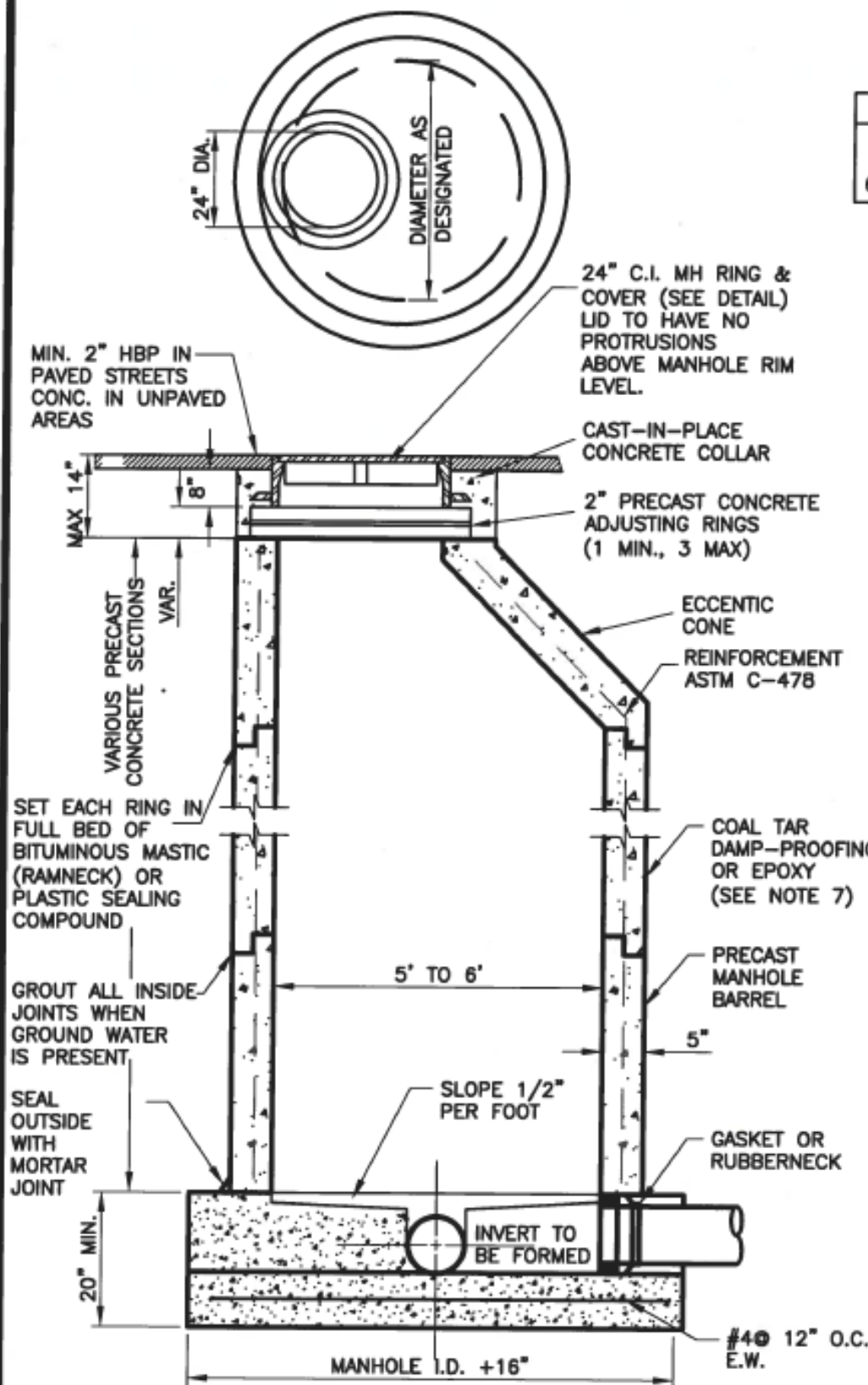

PRECAST MANHOLE

DRAWN: GSM	REVISED: MAY 2018
DATE: JAN. 04	REVISED:
SCALE: NONE	REVISED:

WW-3



DONALA WATER &
SANITATION DISTRICT

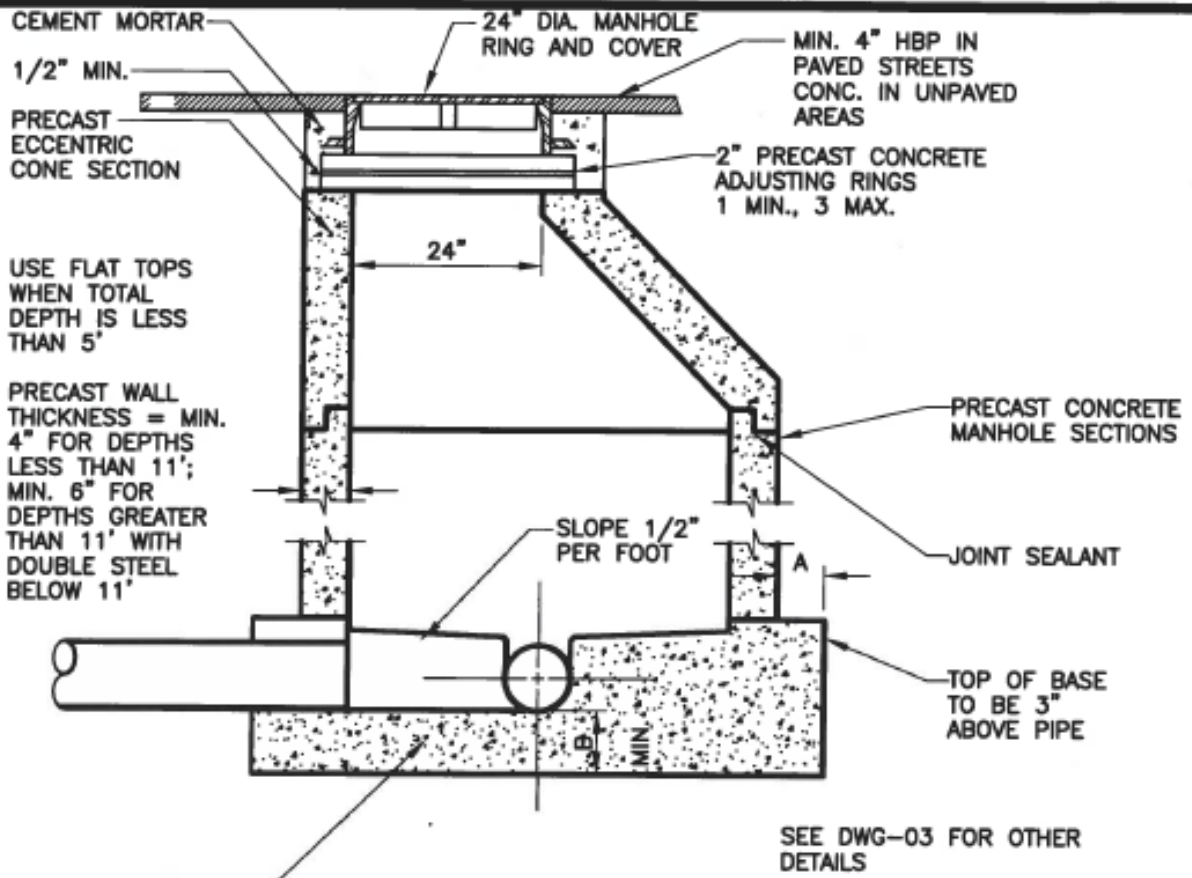

BASE MAY BE PRECAST CONCRETE WITH CAST-IN-PLACE INVERT

SEE DWG-03 FOR OTHER DETAILS

M.H. DEPTH	DIMENSION	
	A	B
0' TO 11'	6"	8"
OVER 11'	6"	10"

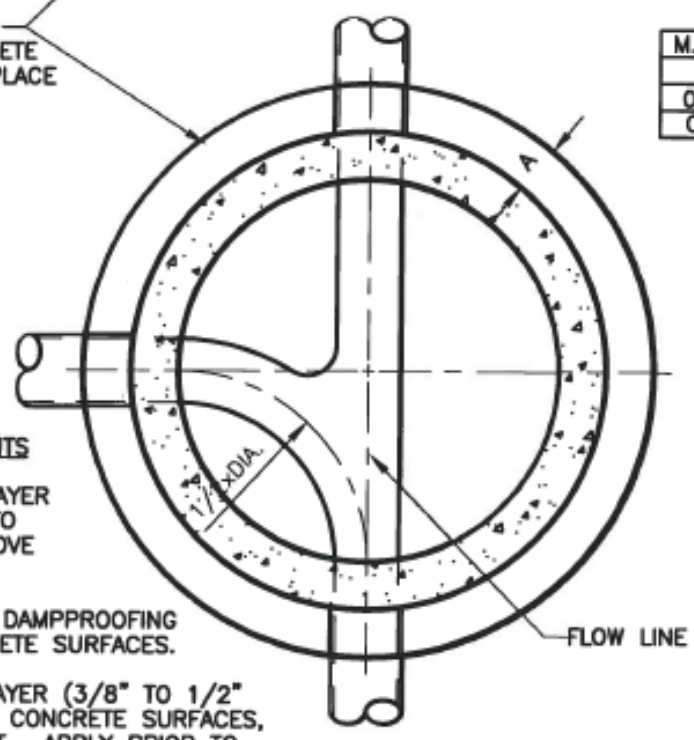

WATERPROOFING REQUIREMENTS

1. APPLY CEMENT GROUT LAYER (3/8" TO 1/2" THICK) TO ALL INTERIOR JOINTS ABOVE FLOW CHANNEL.
2. APPLY COAL TAR EPOXY DAMPPROOFING TO ALL EXTERIOR CONCRETE SURFACES.
3. APPLY CEMENT GROUT LAYER (3/8" TO 1/2" THICK) TO ALL EXTERIOR CONCRETE SURFACES, AS DIRECTED BY DISTRICT. APPLY PRIOR TO DAMPPROOFING.



DONALA WATER & SANITATION DISTRICT

SANTARY SEWER MANHOLE

DRAWN: GSM	REVISED: MAY 2018	WW-4
DATE: JAN 2004	REVISED:	
SCALE: NONE	REVISED:	

G:\DONALAVISTDSPECS\Sanitary\Draw-4.dwg, 8.5x11, 5/3/2018 12:52:17 PM, sc, Xerox AltaLink C8035, 1:1

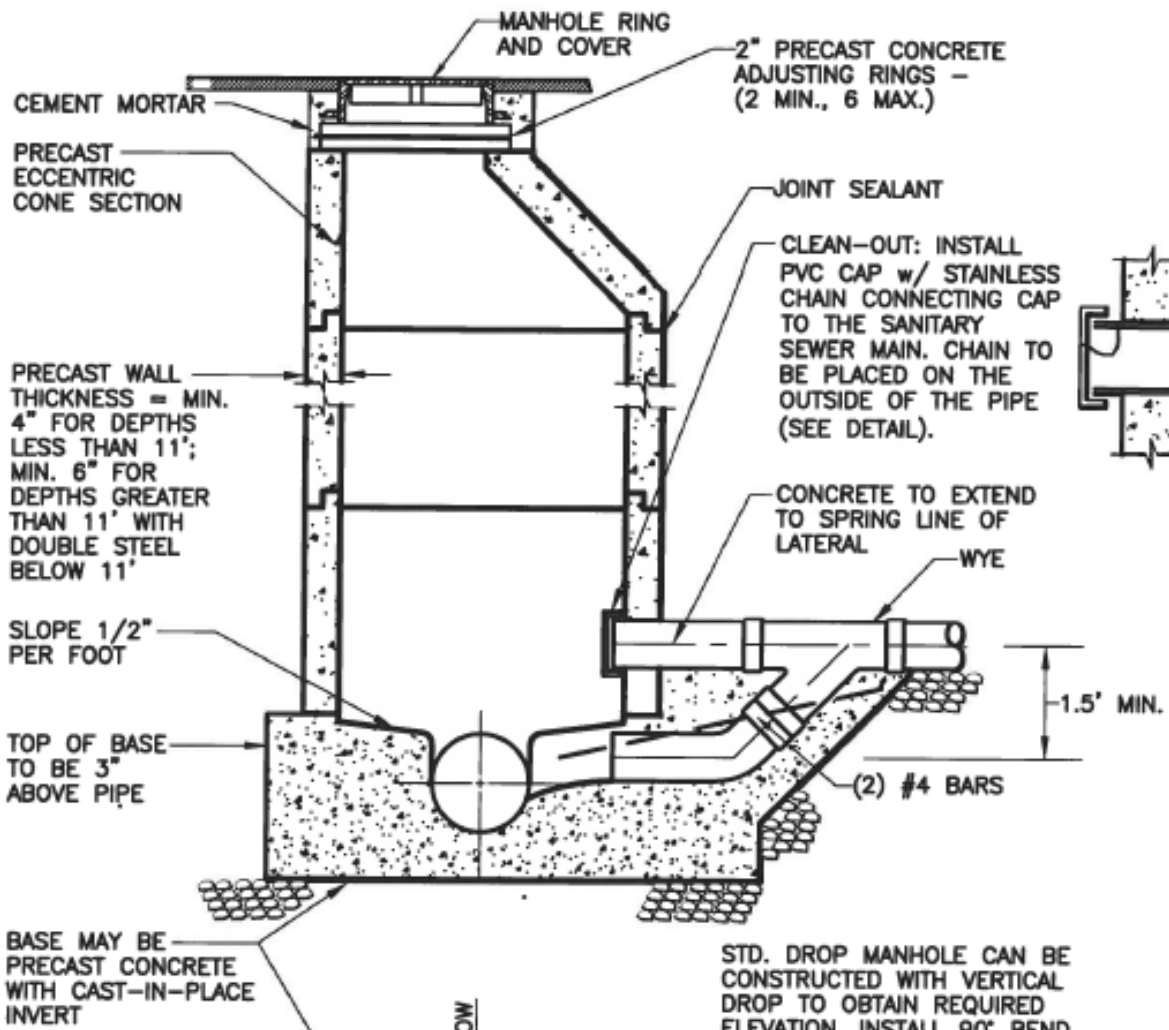

STD. DROP MANHOLE CAN BE CONSTRUCTED WITH VERTICAL DROP TO OBTAIN REQUIRED ELEVATION, INSTALL 90° BEND @ BOTTOM OF DROP

WATER TIGHTNESS REQUIREMENTS

1. APPLY CEMENT GROUT LAYER (3/8" TO 1/2" THICK) TO ALL INTERIOR SURFACES ABOVE FLOW CHANNEL.
2. APPLY COAL TAR DAMPPROOFING TO ALL EXTERIOR CONCRETE SURFACES.
3. APPLY CEMENT GROUT LAYER (3/8" TO 1/2" THICK) TO ALL EXTERIOR CONCRETE SURFACES, AS DIRECTED BY DISTRICT. APPLY PRIOR TO DAMPPROOFING.

SEE DWG WW-3 FOR OTHER DETAILS AND REQUIREMENTS

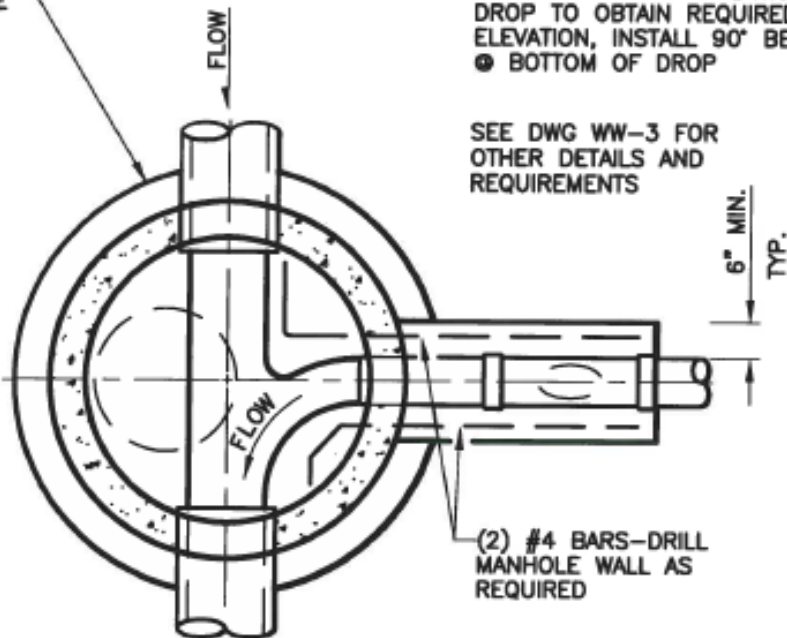

SANITARY SEWER-DROP MANHOLE



DONALA WATER & SANITATION DISTRICT

DRAWN: GSM	REVISED: MAY 2018
DATE: JAN 2004	REVISED:
SCALE: NONE	REVISED:

WW-5

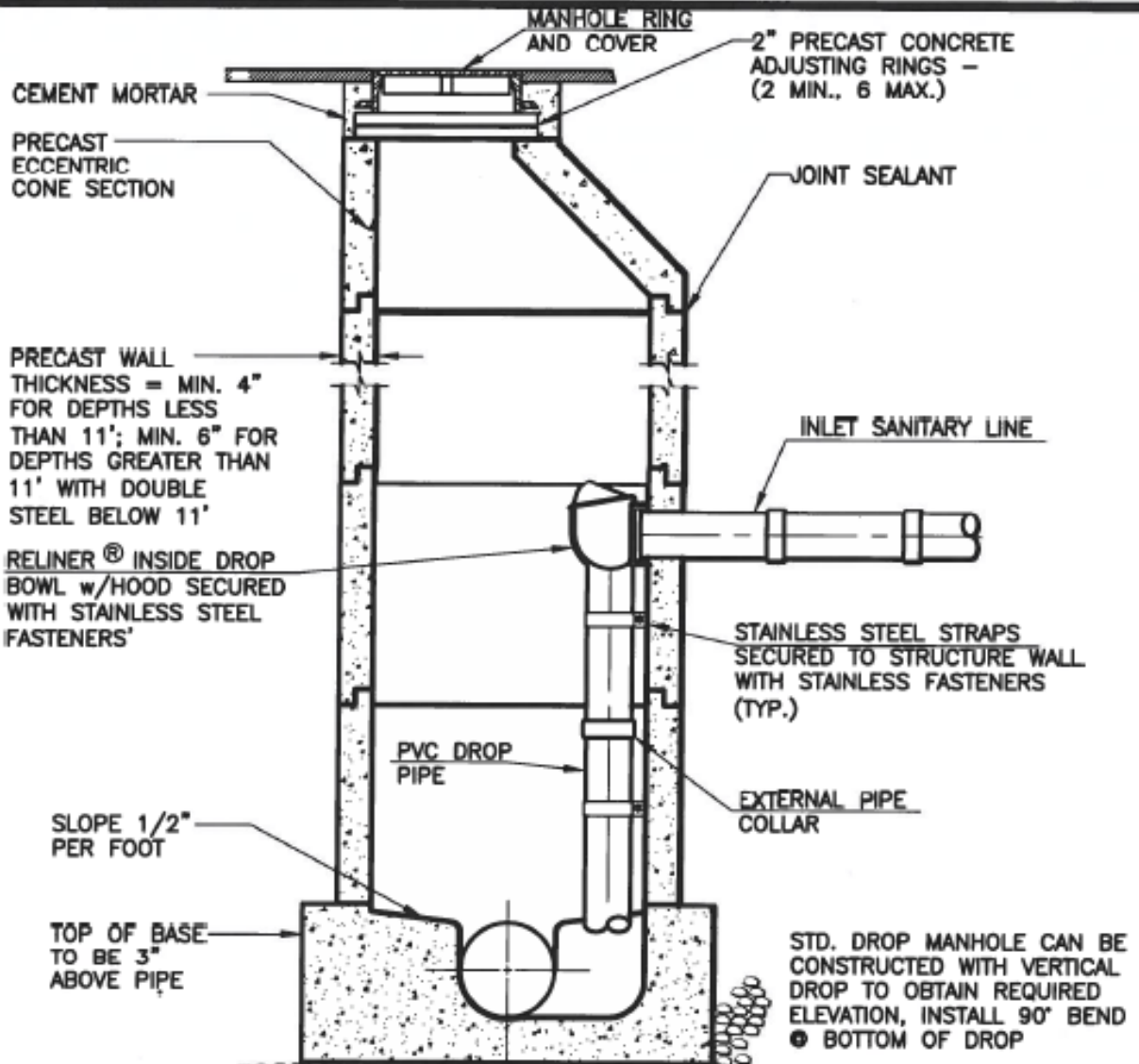

WATER TIGHTNESS REQUIREMENTS

1. APPLY CEMENT GROUT LAYER (3/8" TO 1/2" THICK) TO ALL INTERIOR SURFACES ABOVE FLOW CHANNEL.
2. APPLY COAL TAR DAMPPROOFING TO ALL EXTERIOR CONCRETE SURFACES.
3. APPLY CEMENT GROUT LAYER (3/8" TO 1/2" THICK) TO ALL EXTERIOR CONCRETE SURFACES, AS DIRECTED BY DISTRICT. APPLY PRIOR TO DAMPPROOFING.

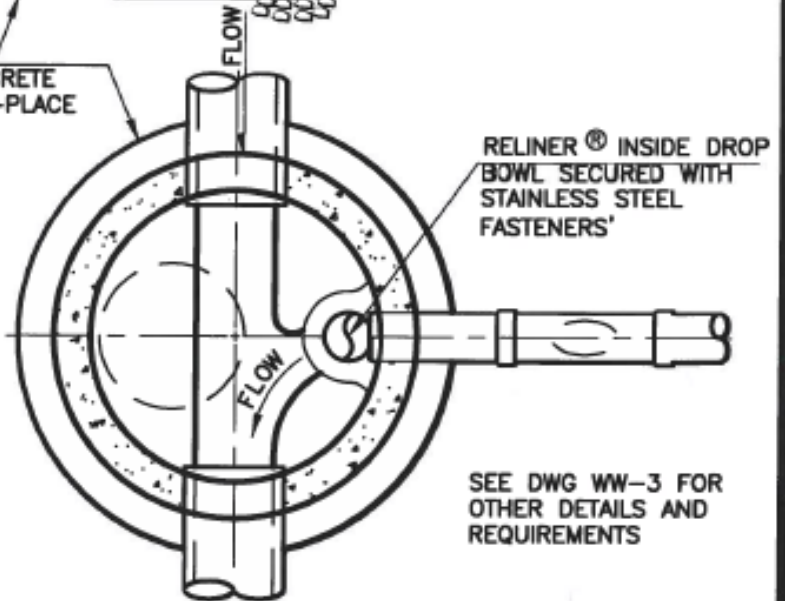

SANITARY SEWER DROP MANHOLE



DONALA WATER & SANITATION DISTRICT

DRAWN: RGG	REVISED: 10-09-17 UPDATED RELINER NOTE
DATE: FEB 2006	REVISED: MAY 2018
SCALE: NONE	REVISED:

WW-5A

G:\DONALAWATER\PROJECTS\11-11-10\11-11-10.dwg 11-11-10 11:11:10 AM 11/11/10 11:11:10 AM

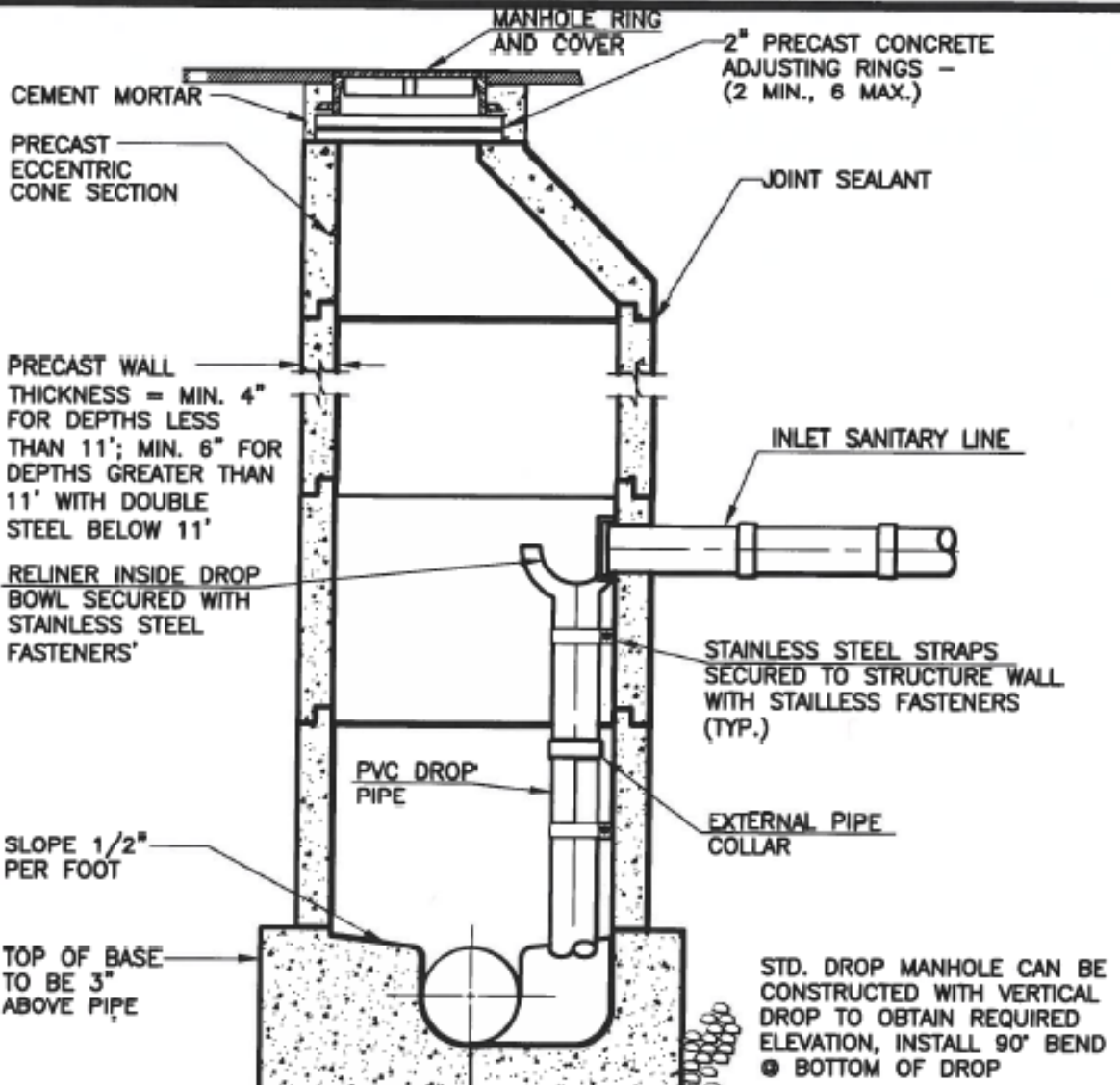

WATER TIGHTNESS REQUIREMENTS

1. APPLY CEMENT GROUT LAYER (3/8" TO 1/2" THICK) TO ALL INTERIOR SURFACES ABOVE FLOW CHANNEL.
2. APPLY COAL TAR DAMPPROOFING TO ALL EXTERIOR CONCRETE SURFACES.
3. APPLY CEMENT GROUT LAYER (3/8" TO 1/2" THICK) TO ALL EXTERIOR CONCRETE SURFACES, AS DIRECTED BY DISTRICT. APPLY PRIOR TO DAMPPROOFING.

STD. DROP MANHOLE CAN BE CONSTRUCTED WITH VERTICAL DROP TO OBTAIN REQUIRED ELEVATION, INSTALL 90° BEND @ BOTTOM OF DROP

SEE DWG WW-3 FOR OTHER DETAILS AND REQUIREMENTS

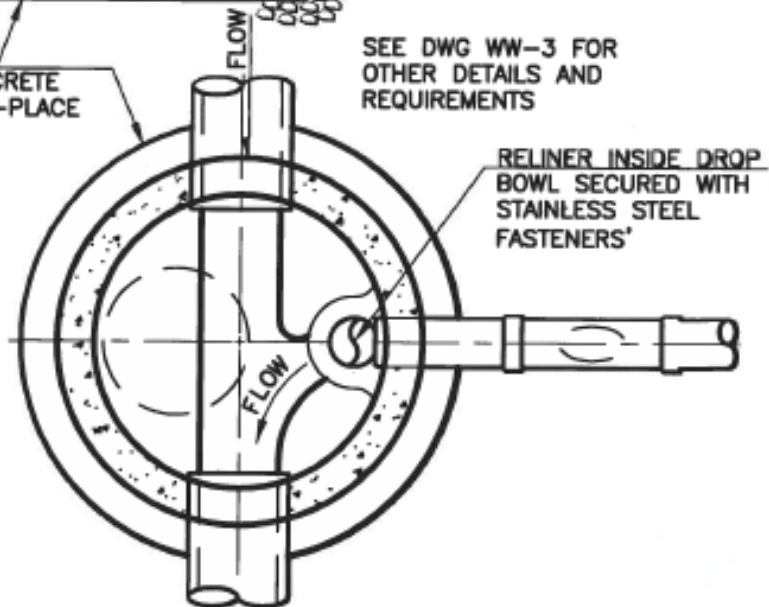

SANITATION DEPARTMENT— SANITARY SEWER DROP MANHOLE



DONALA WATER & SANITATION DISTRICT

DRAWN: RGG	REVISED:
DATE: FEB 2006	REVISED:
SCALE: NONE	REVISED:

WW-5E

G:\DONALAI\STD\SPECS\Sanitary\DWG-6.dwg, 8.5x11, 5/3/2018 12:51:03 PM, ac, Xerox AltaLink C8035, 1:1

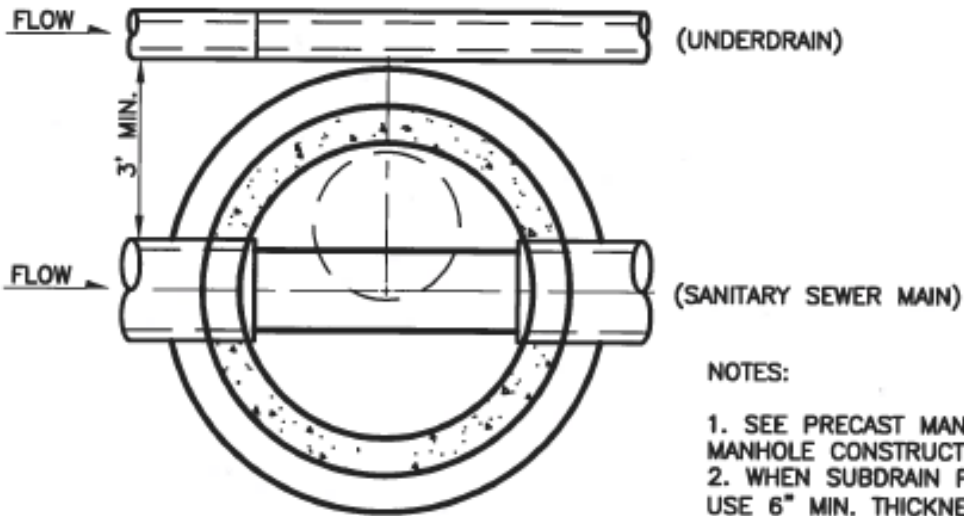
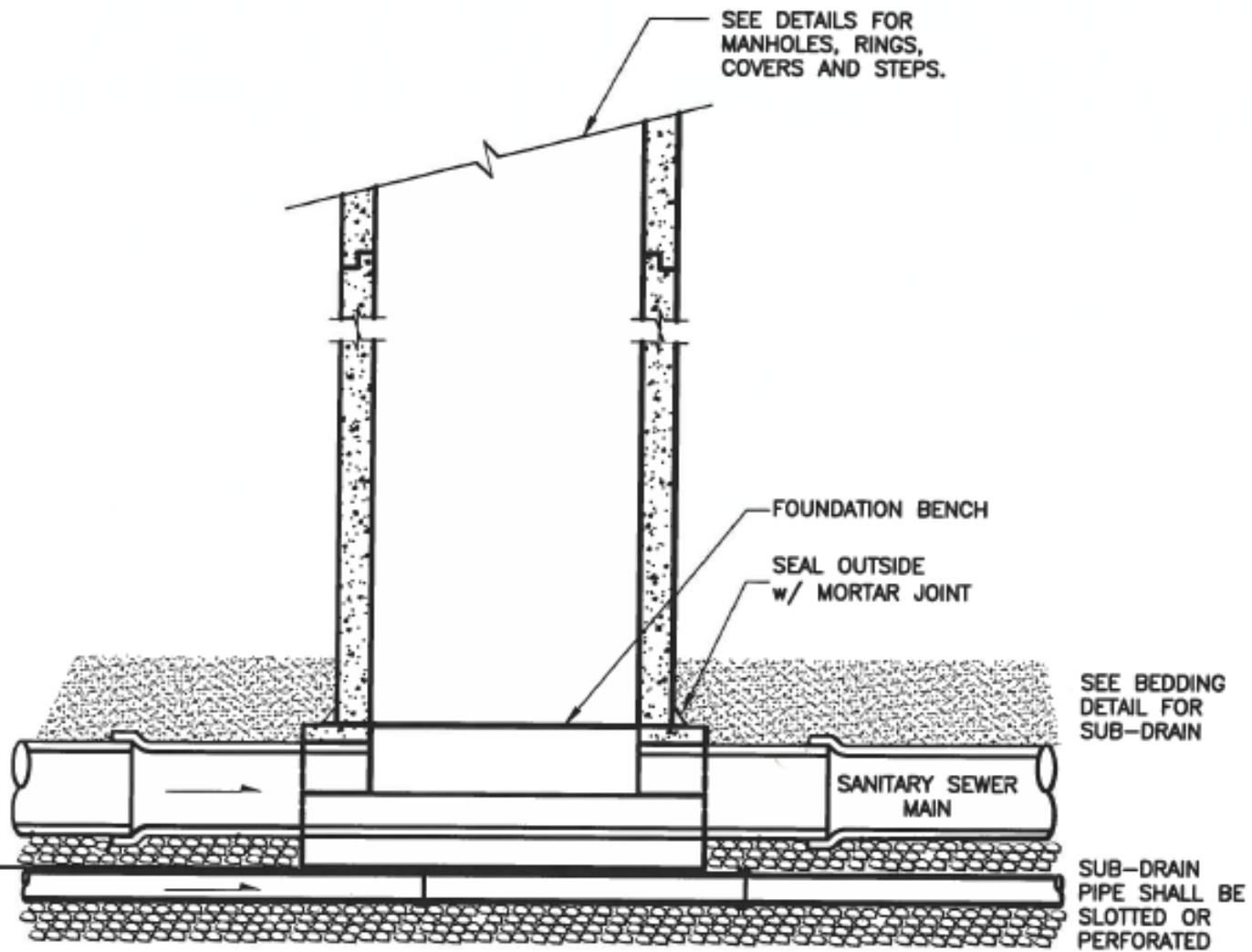

- NOTES:
1. SEE PRECAST MANHOLE DETAILS FOR MANHOLE CONSTRUCTION.
 2. WHEN SUBDRAIN PIPE NOT REQUIRED USE 6" MIN. THICKNESS OF 3/4" ROCK.



MANHOLE WITH UNDERDRAIN

DRAWN: GSM	REVISED:
DATE: JAN 2004	REVISED:
SCALE: NONE	REVISED:

WW-6

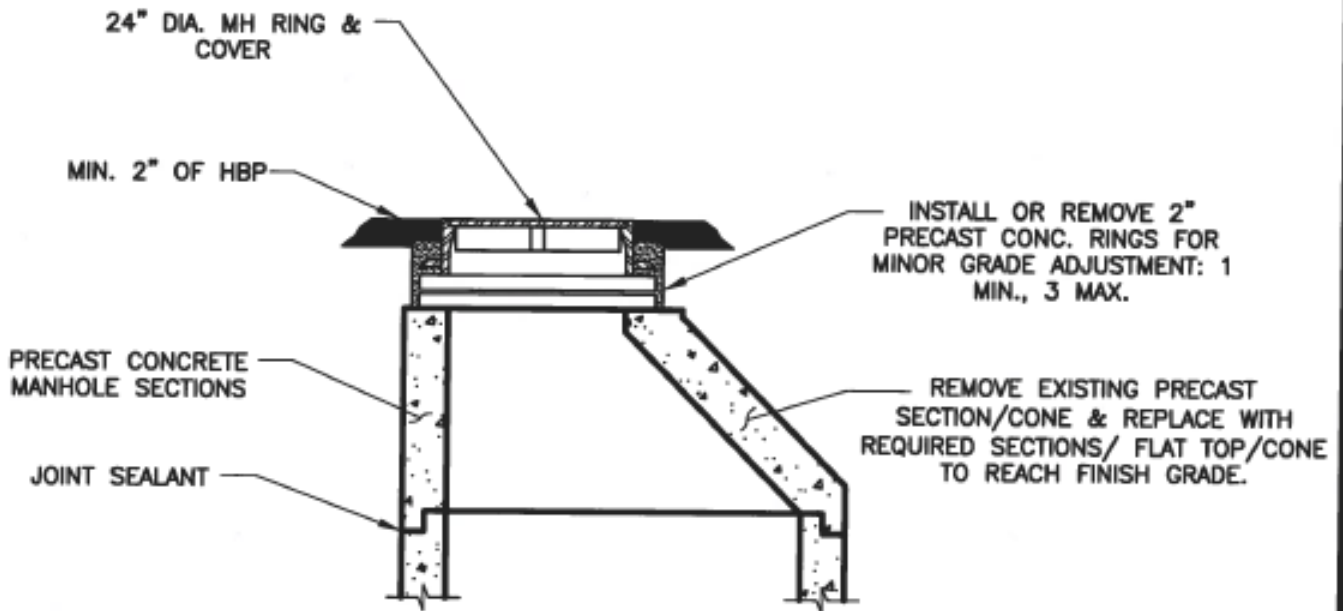
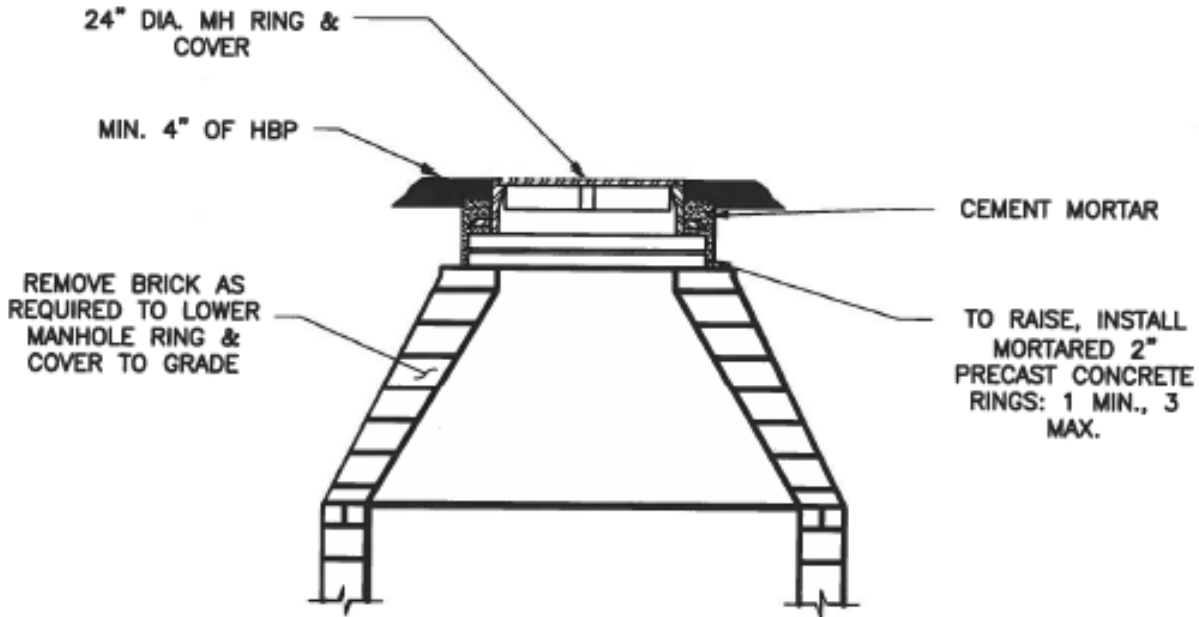

DONALA WATER & SANITATION DISTRICT

MANHOLE RING AND COVER ADJUSTMENT

DRAWN: GSM

REVISED:

DATE: JAN 2004

REVISED:

SCALE: NONE

REVISED:

WW-7

G:\DONALAN\STDSP\PCS\Sanitary\Dwg-8.dwg, 8.5x11, 5/3/2018 12:50:22 PM, sc, Xerox Altalink C8035, 1:1

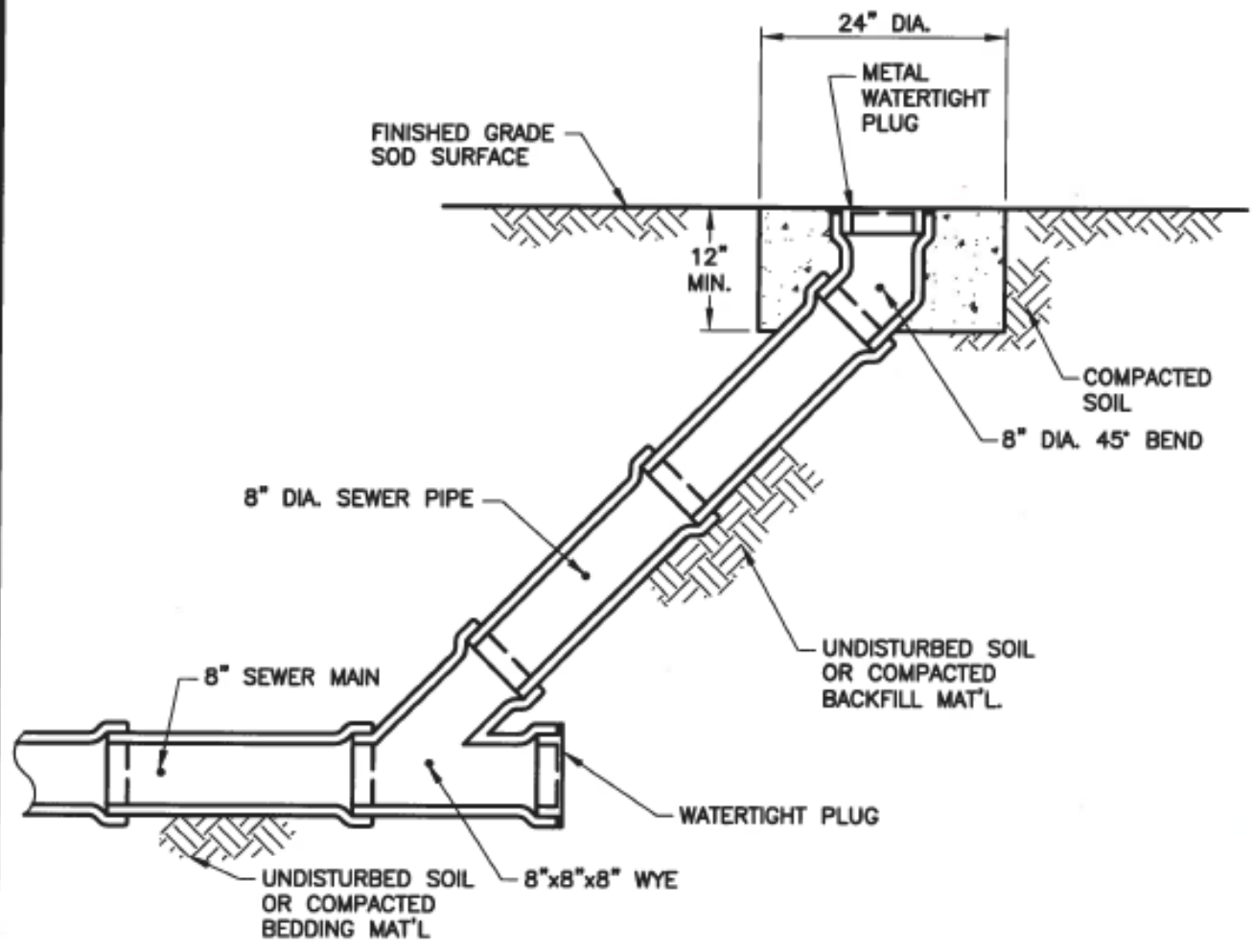

NOTE:

1. SERVICE LINE CLEANOUTS SHALL BE PLACED 2" BELOW GRADE WITH A 10" LONG RISER BOX PLACED AT GRADE WITH "SEWER" CAST IN THE LID.
2. END OF LINE CLEANOUTS NOT ALLOWED ON DWSD MAINS UNLESS AUTHORIZED.



DONALA WATER & SANITATION DISTRICT

SANITARY SEWER MAIN CLEAN-OUT

DRAWN: GSM	REVISED: MAY 2018
DATE: JAN 2004	REVISED:
SCALE: NONE	REVISED:

WW-8

G:\DONALIA\ISTDSPECS\Sanitary\Dwg-9.dwg, 8.5x11, 5/3/2018 1:50:31 PM, sc, Xerox AltaLink C8035, 1:1

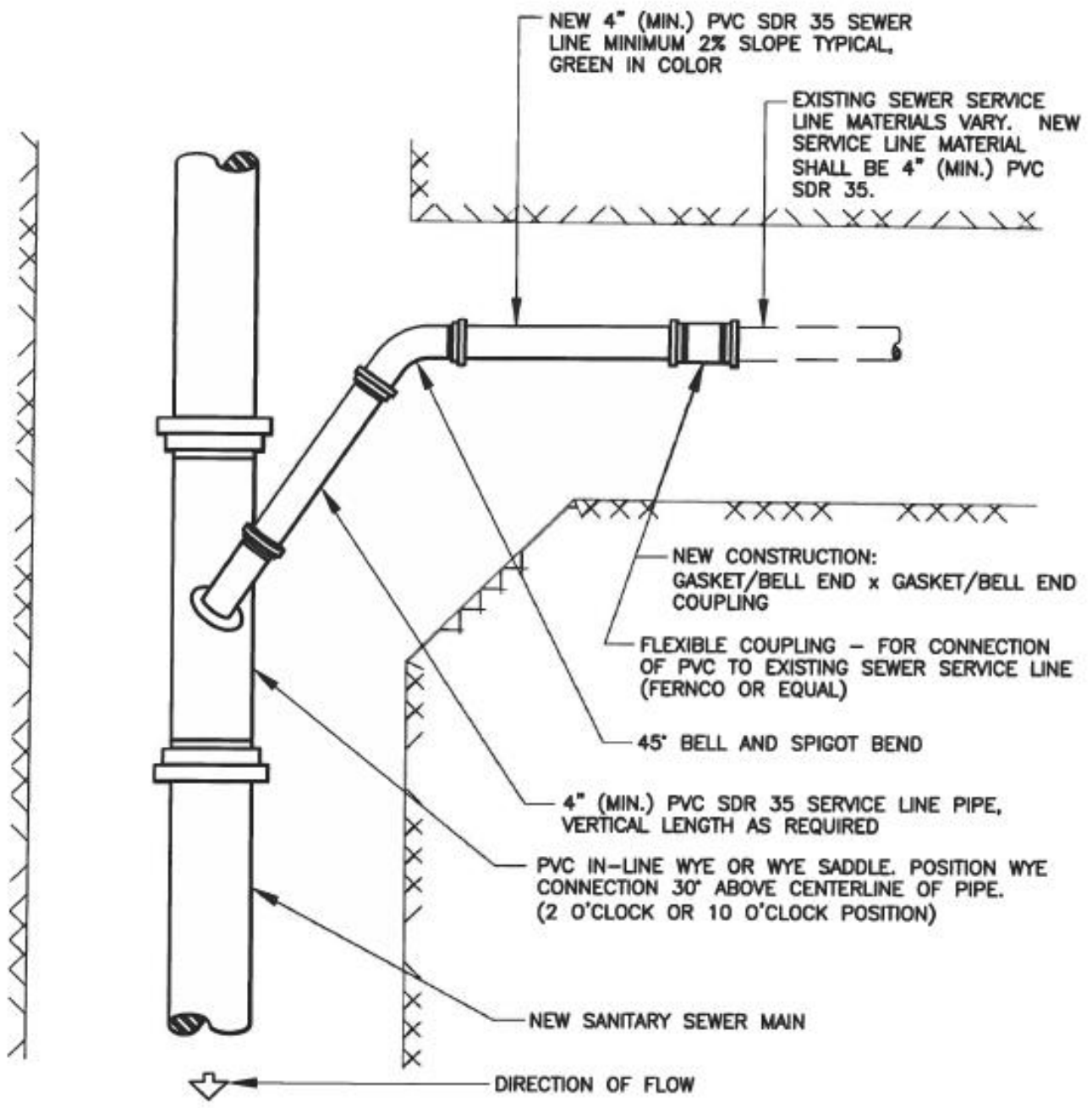

SANITARY SEWER SERVICE CONNECTION



DRAWN: GSM DATE: JAN 2004 SCALE: NONE	REVISED: MAY 2018 REVISED: REVISED:
---	---

WW-9

CONCRETE ENCASEMENT SHOWN CUT AWAY TO REVEAL REBAR

CONCRETE ENCASEMENT

PIPELINE

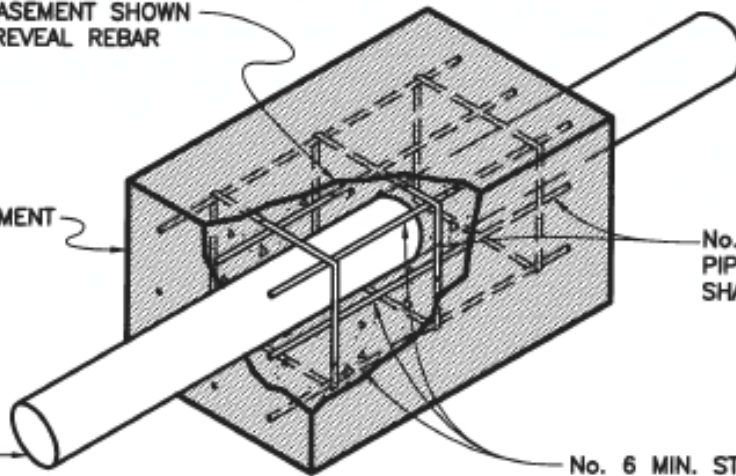

No. 3 STIRRUPS PERPENDICULAR TO PIPELINE ON 12" CENTERS. LAP SHALL BE A MIN. OF 12".

No. 6 MIN. STEEL REINFORCING BARS PARALLEL TO PIPELINE ENTIRE LENGTH OF CONCRETE ENCASEMENT ON 12" CENTERS. NUMBER OF BARS VARIES DEPENDING UPON THE PIPE DIAMETER. OVERLAP SHALL BE 36 TIMES THE BAR DIAMETER.

LINED OR UNLINED DRAINAGE STRUCTURE OR UTILITY (ANY WIDTH OR DIAMETER)

TOP OF GROUND

OPEN CHANNEL

ENCLOSED PIPE

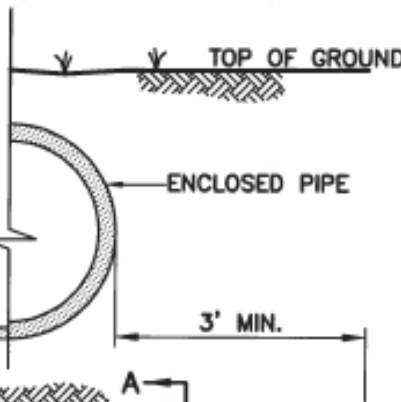

5' MIN.

3' MIN.

3' MIN.

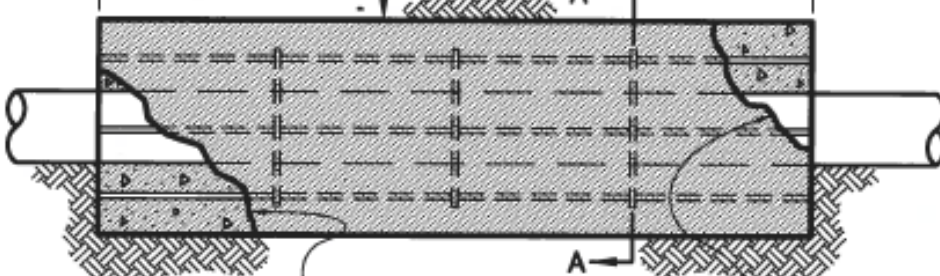

CONCRETE ENCASEMENT SHOWN CUT AWAY TO REVEAL REBAR

ELEVATION

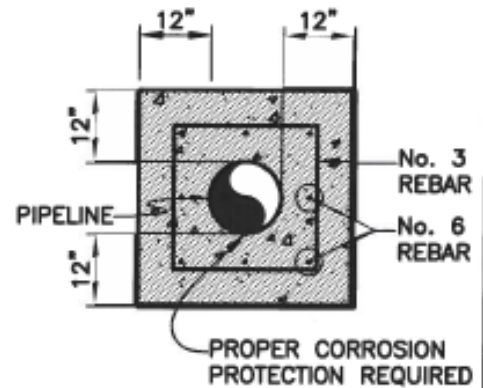

SECTION A-A

PIPELINE



DONALA WATER & SANITATION DISTRICT

PIPE ENCASEMENT

DRAWN: GSM

REVISED:

DATE: JAN 2004

REVISED:

SCALE: NONE

REVISED:

WW-10

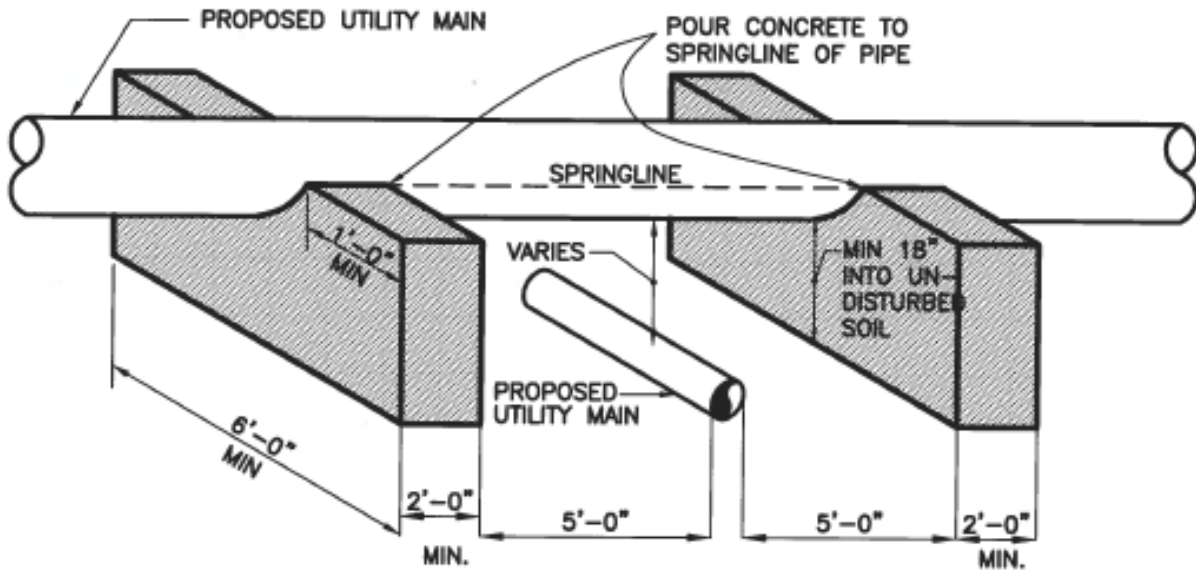

NOTES :

1. CONCRETE BRIDGING BLOCKS TO BE REINFORCED WITH No. 6 REBAR SET ON 12" CENTERS.
2. NO JOINTS OF UTILITY MAIN SHALL BE ALLOWED BETWEEN CONCRETE BRIDGING BLOCKS.

G:\DONALIA\STD\SPEC\S\SanitaryDwg-12.dwg, 8.5x11, 5/3/2018 12:49:05 PM, ac, Xerox Altalink C8035, 1:1



DONALA WATER & SANITATION DISTRICT

PIPE BRIDGING

DRAWN: GSM	REVISED:
DATE: JAN 2004	REVISED:
SCALE: NONE	REVISED:

WW-12

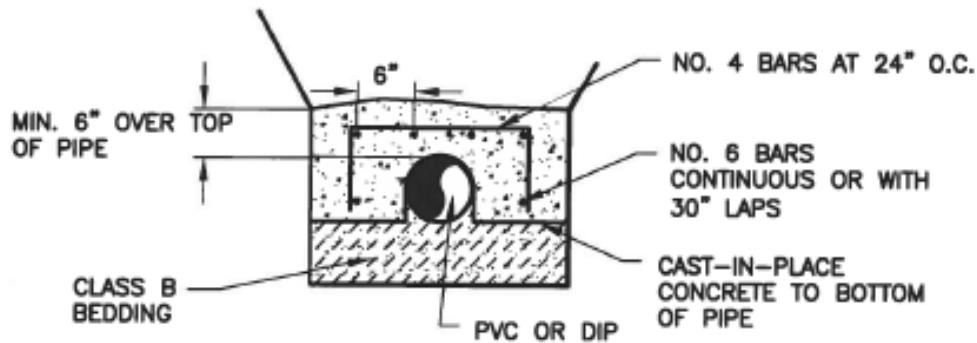
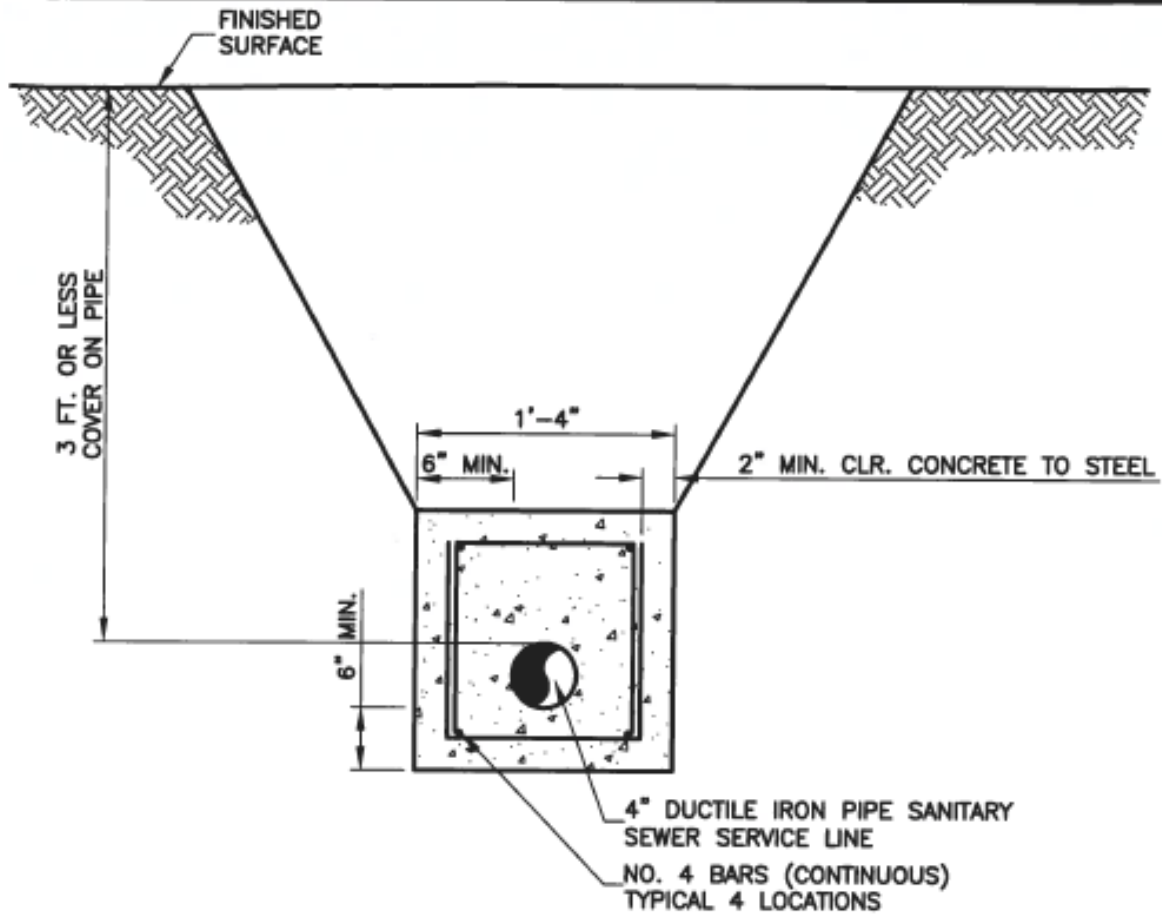

REINFORCED CONCRETE PIPE CAP

NOTES:

1. DUCTILE IRON PIPE WITHOUT CONCRETE ENCASEMENT MAY BE PERMITTED BY THE DISTRICT IF FINAL PIPE COVER IS MORE THAN 3 FEET.
2. CONCRETE ENCASEMENT PER THIS DRAWING IS REQUIRED WITH DUCTILE IRON PIPE WHERE FINAL PIPE COVER IS 3 FEET OR LESS.
3. IF THE CONCRETE ENCASEMENT IS REQUIRED ON A SANITARY SEWER SERVICE LINE, THE PROPERTY OWNER/CUSTOMER IS COMPLETELY RESPONSIBLE FOR OPERATION, MAINTENANCE AND REPLACEMENT OF ANY SEWER SERVICE LINE FROM THE DISTRICT'S SEWER MAIN TO THE STRUCTURE SERVED.
4. THE DISTRICT MAY ACCEPT CONCRETE CAP FOR PIPE PROTECTION IN SPECIAL CONDITIONS



DONALA WATER & SANITATION DISTRICT

SHALLOW SANITARY SEWER LINE PROTECTION/ENCASEMENT

DRAWN: GSM

REVISED:

DATE: JAN 2004

REVISED:

SCALE: NONE

REVISED:

WW-13

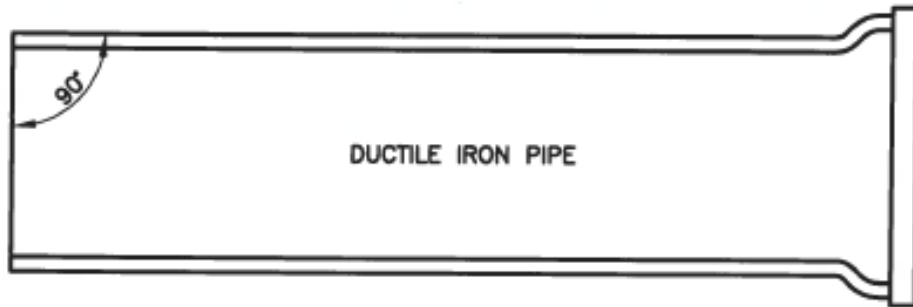

MECHANICAL JOINT CONNECTION

PIPE MUST BE CUT AT RIGHT ANGLES TO LONGITUDINAL CENTERLINE IN ALL CASES.

PIPE ENDS SHALL BE FREE OF BURRS.

MORTAR LINING SHALL BE FLUSH WITH PIPE END.

GOUGES CUT IN PIPE ENDS SHALL NOT BE ALLOWED.

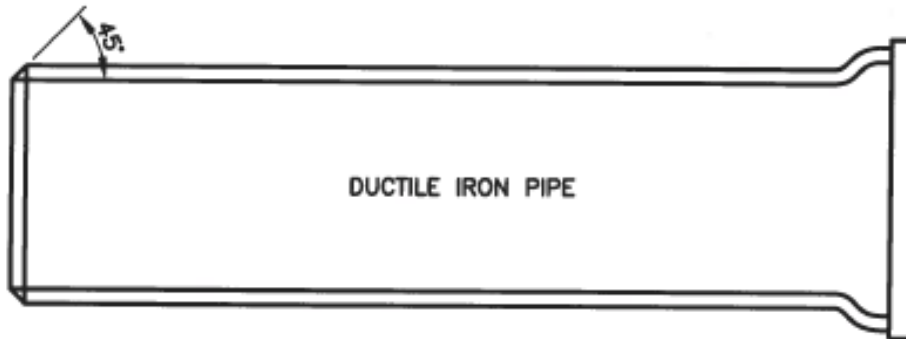

SLIP JOINT CONNECTION

PIPE CUT IN STRAIGHT LINE AND BEVELED AT 45° ANGLE ON END.

GENERAL NOTES:

1. ALL PIPE CUTTING EQUIPMENT AND PIPE CUTS MUST BE APPROVED BY THE DISTRICT.
2. ALL PIPE ENDS TO BE USED IN INSTALLATION SHALL BE DRESSED SMOOTH TO THE SATISFACTION OF THE INSPECTOR PRIOR TO INSTALLATION.
3. PREPARE SURFACE AND APPLY COATINGS ON ALL BARE METAL SURFACE TO MATCH INTERNAL PIPE LINING OR APPLY EPOXY POLYAMIDE, 10 MILS. MIN., UNLESS OTHERWISE SPECIFIED.



DONALA WATER & SANITATION DISTRICT

PIPE CUTTING

DRAWN: GSM

REVISED:

DATE: JAN 2004

REVISED:

SCALE: NONE

REVISED:

WW-14

FIELD INSTALLATION OF POLYETHYLENE WRAP

STEP 1:

PLACE TUBE OF POLYETHYLENE MATERIAL ON PIPE PRIOR TO LOWERING IT INTO TRENCH.

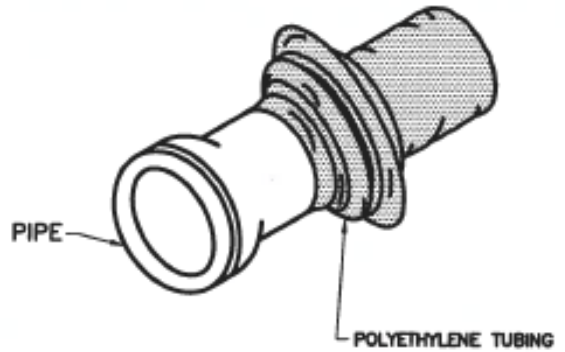

STEP 2:

PULL TUBE OVER THE LENGTH OF THE PIPE. TAPE TUBE TO END AT JOINT. FOLD MATERIAL AROUND THE ADJACENT SPIGOT END AND WRAP WITH TAPE TO HOLD THE PLASTIC TUBE IN PLACE. INSTALL BONDING STRAP OR WIRE AT EVERY JOINT OF PIPE PRIOR TO WRAPPING IN ACCORDANCE WITH THE STANDARD SPECIFICATIONS.

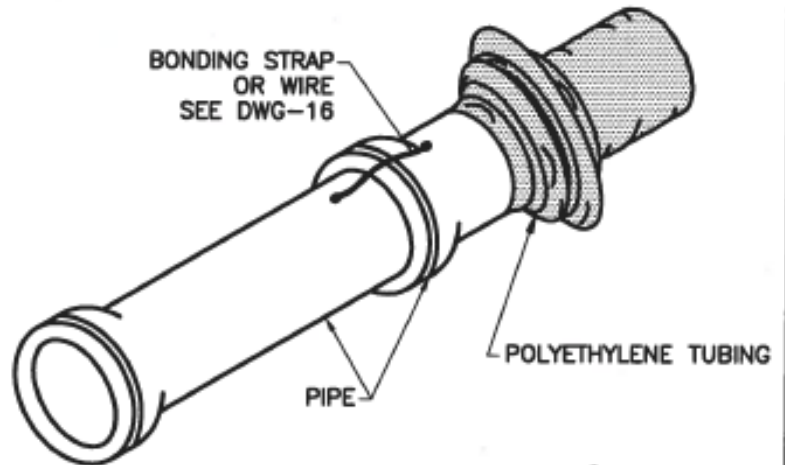

STEP 3:

OVERLAP FIRST TUBE WITH ADJACENT TUBE AND SECURE WITH PLASTIC ADHESIVE TAPE. THE POLYETHYLENE TUBE MATERIAL COVERING THE PIPE SHALL BE LOOSE. EXCESS MATERIAL SHALL BE NEATLY DRAWN UP AROUND THE PIPE BARREL, FOLDED ON TOP OF PIPE AND TAPED IN PLACE.

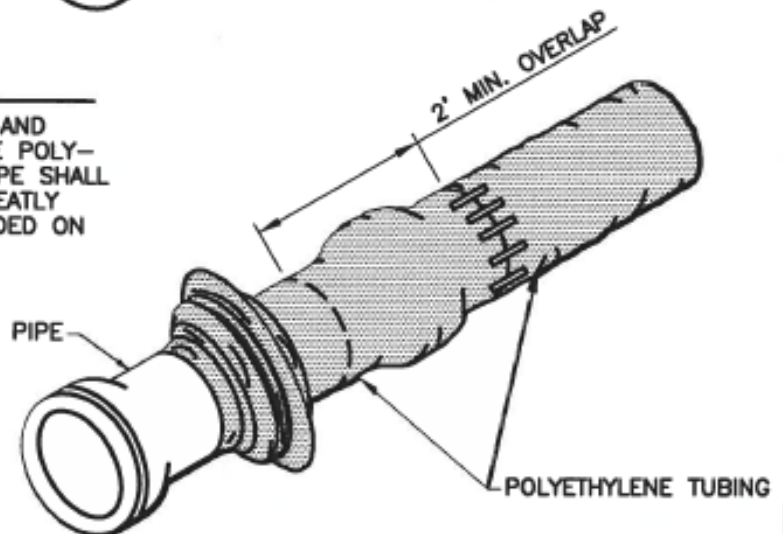

DONALA WATER & SANITATION DISTRICT

POLYETHYLENE PIPE WRAP

DRAWN: GSM	REVISED:
DATE: JAN 2004	REVISED:
SCALE: NONE	REVISED:

WW-15

NOTES :

1. MINIMUM SIZE = 1500 GALLON
2. CONCRETE = 28 DAY COMPRESSIVE STRENGTH = 4500 psi
3. DESIGN: ASTM C857-87 & C858-83 MINIMUM
4. LOADING: AASHTO HS-20
5. FILL w/ CLEAN WATER PRIOR TO START-UP OF SYSTEM

SIZING CHART

GALLON CAPACITY	DIM "A"	DIM "B"	DIM "C"	DIM "D"
1500	9'-0"	5'-8"	7'-2"	4'-4"
1750	11'-2"	5'-8"	7'-2"	4'-11"
2000	11'-2"	6'-8"	8'-0"	4'-7"
2500	12'-8"	6'-8"	8'-0"	5'-6"
2750	12'-8"	6'-8"	8'-0"	6'-0"
3000	15'-7"	9'-7"	8'-6.5"	6'-3"
4000	15'-7"	9'-7"	8'-6.5"	6'-3"
5000	19'-11"	9'-11"	8'-11"	6'-2"
6000	19'-11"	9'-11"	10'-5"	7'-2"

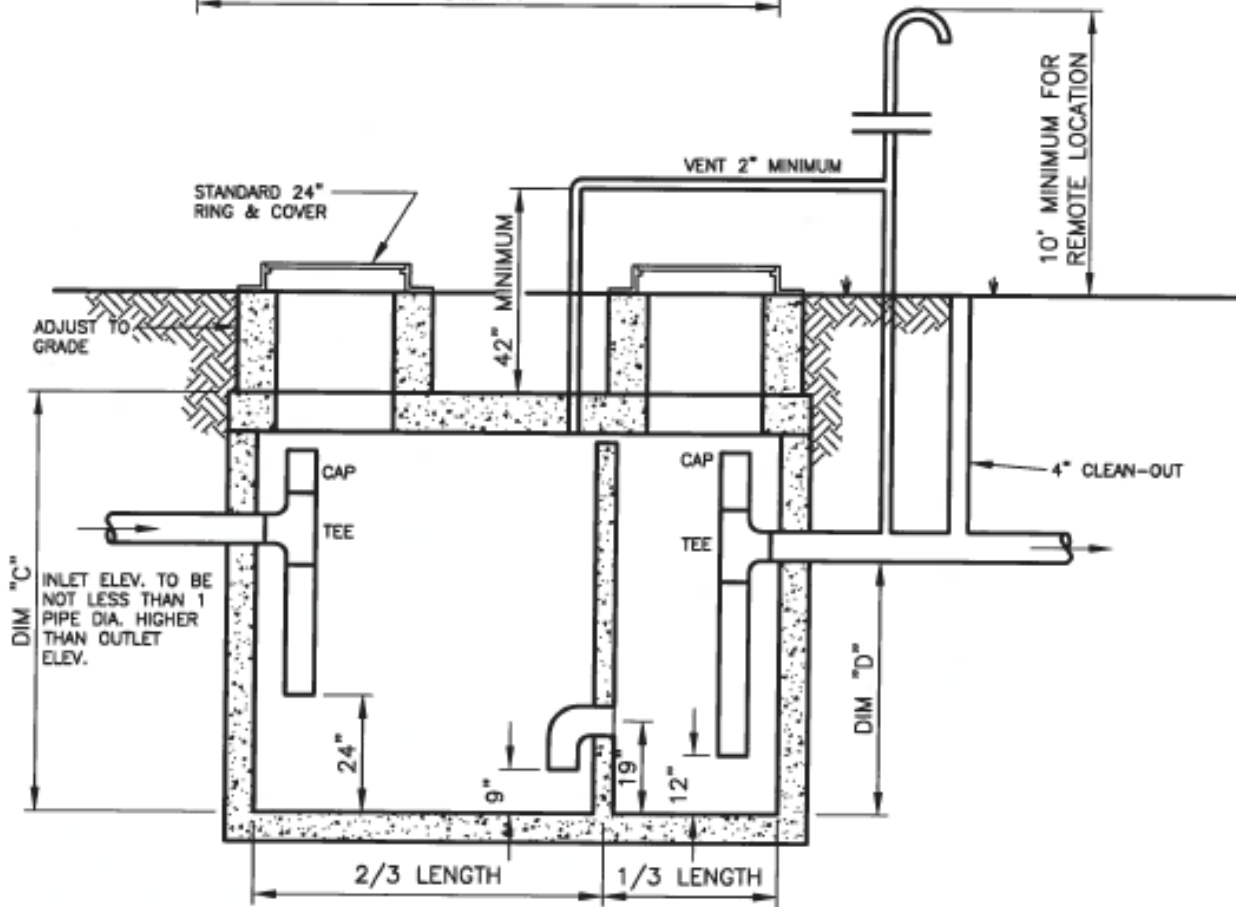
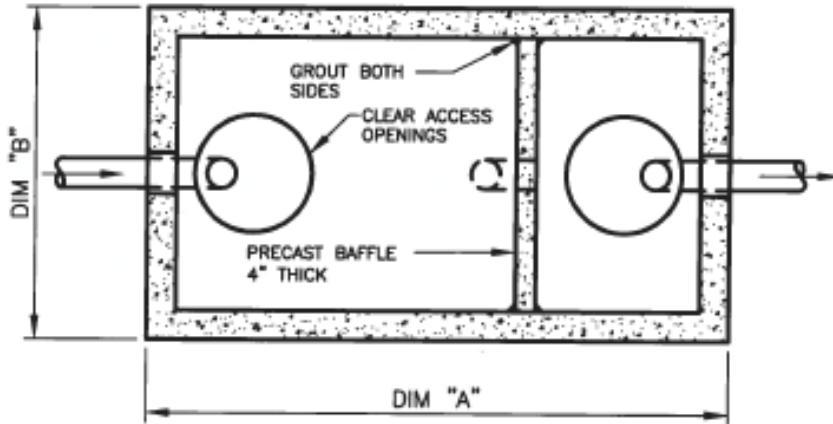

GREASE INTERCEPTOR



DONALA WATER & SANITATION DISTRICT

DRAWN: GSM	REVISED: MAY 2018
DATE: JAN 2004	REVISED:
SCALE: NONE	REVISED:

WW-18

NOTES :

1. MINIMUM SIZE = 1,500 GALLON
2. CONCRETE = 28 DAY COMPRESSIVE STRENGTH = 4500 psi
3. DESIGN: ASTM C857-87 & C858-83 MINIMUM
4. LOADING: AASHTO HS-20
5. FILL w/ CLEAN WATER PRIOR TO START-UP OF SYSTEM

SIZING CHART

GALLON CAPACITY	DIM "A"	DIM "B"	DIM "C"	DIM "D"	DIM "E"	DIM "F"
1500	8'-0"	4'-0"	6'-2"	6'-4"	7'-0"	5'-2"
1800	11'-0"	4'-0"	5'-6"	5'-8"	7'-0"	4'-6"
2000	12'-6"	6'-0"	4'-0"	4'-2"	5'-0"	3'-0"
2500	12'-6"	6'-0"	5'-0"	5'-2"	6'-0"	4'-0"
3000	12'-6"	6'-0"	6'-0"	6'-2"	7'-0"	5'-0"
3500	16'-0"	8'-0"	4'-0"	4'-2"	6'-0"	3'-0"
5000	16'-0"	8'-0"	5'-6"	5'-8"	7'-0"	4'-6"
5500	16'-0"	8'-0"	6'-0"	6'-2"	7'-0"	5'-0"

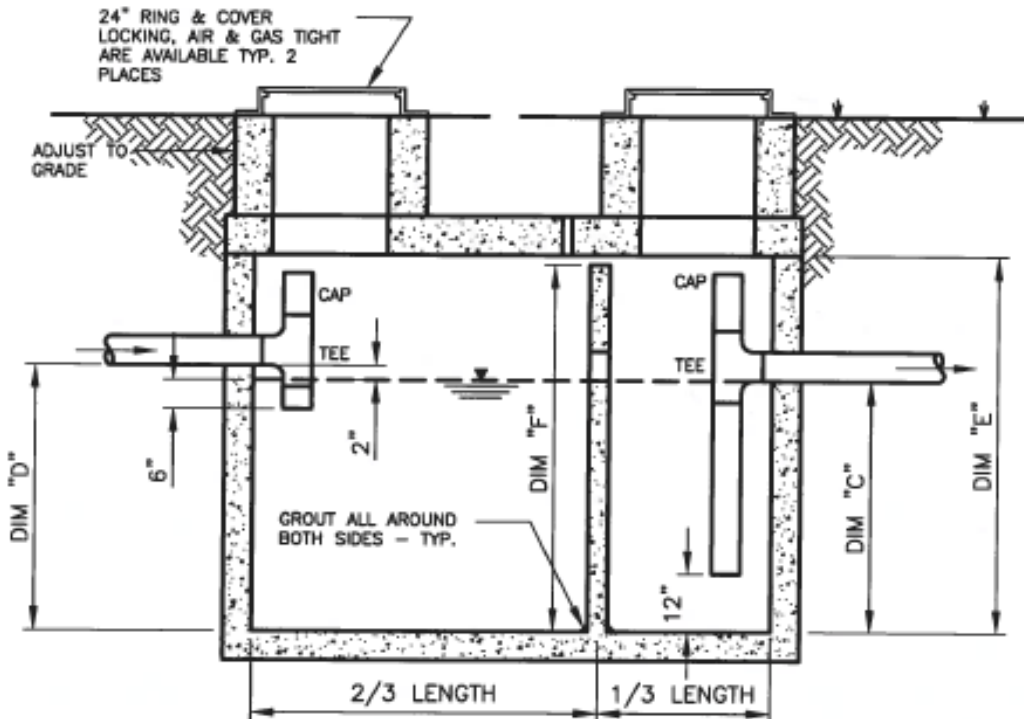
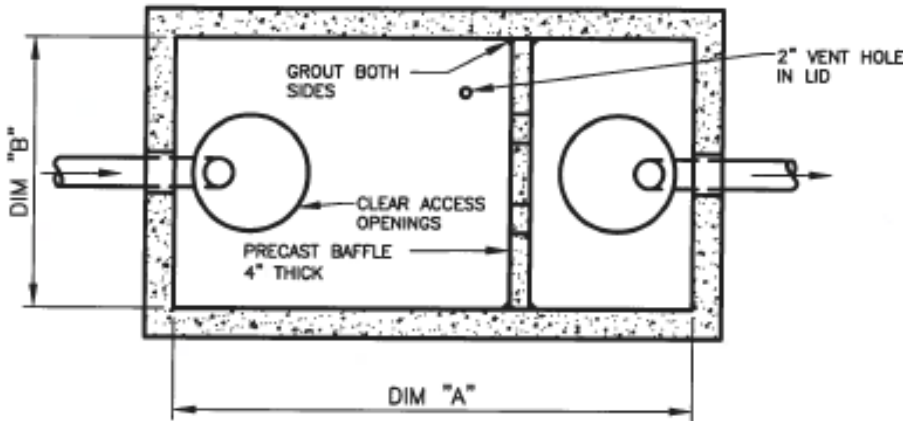

SAND/OIL SEPARATOR



DONALA WATER & SANITATION DISTRICT

DRAWN: GSM

REVISED: MAY 2018

DATE: JAN 2004

REVISED:

SCALE: NONE

REVISED:

WW-19

G:\DONALA\STD\SPECS\Sanitary\DWg-19.dwg, 8.5x11, 5/3/2018 1:21:58 PM, sc, Xerox AltaLink C8035, 1:1

G:\DONALAI\STD\SPECS\Sanitary\DWg-20.dwg, 8.5x11, 5/3/2018 1:22:16 PM, sc, Xerox Altalink C8035, 1:1

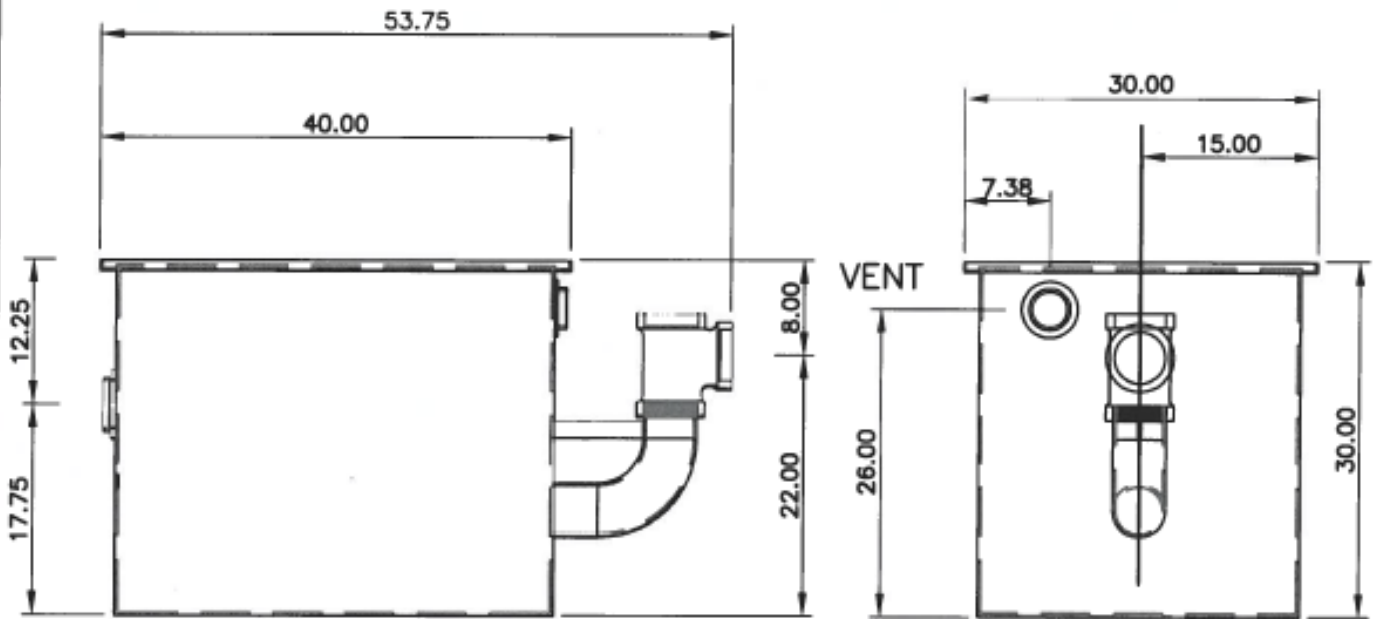
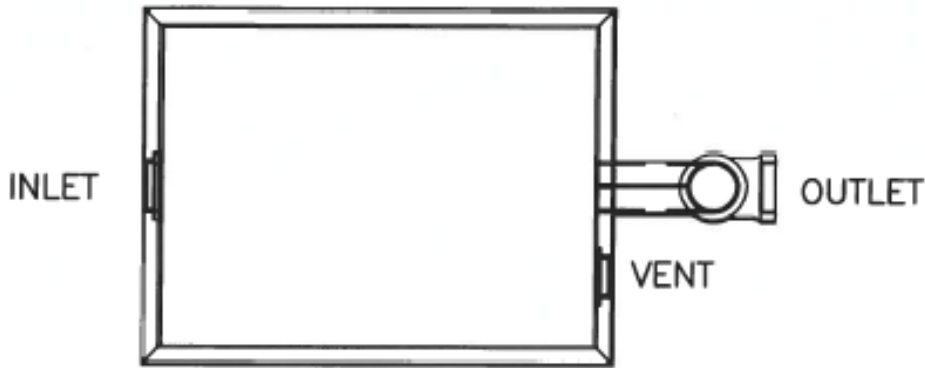

INLET

OUTLET

REQUIRES APPROVAL BY DWSD

Specifications

All welded 1/4" steel separator, 85 gallon static capacity, 4.00" tapped inlet/outlet with 3.00" tapped internal vent connection, 250 lbs greasy sludge capacity, visible double-wall outside trap seal, separator plate and removable filter screen, removable 3/8" nonskid diamond treadplate covers for flush with floor installation suitable for pedestrian traffic secured with stainless flat head screws, heavy duty leak-proof gasket, OPEX Shop Coat coating inside and bituminous coating outside. Rockford Model GIS-50 or approved equivalent



DONALA WATER & SANITATION DISTRICT

GREASE SEPARATOR = 250 lbs.

DRAWN: GSM	REVISED: MAY 2018
DATE: JAN 2004	REVISED:
SCALE: NONE	REVISED:

WW-20

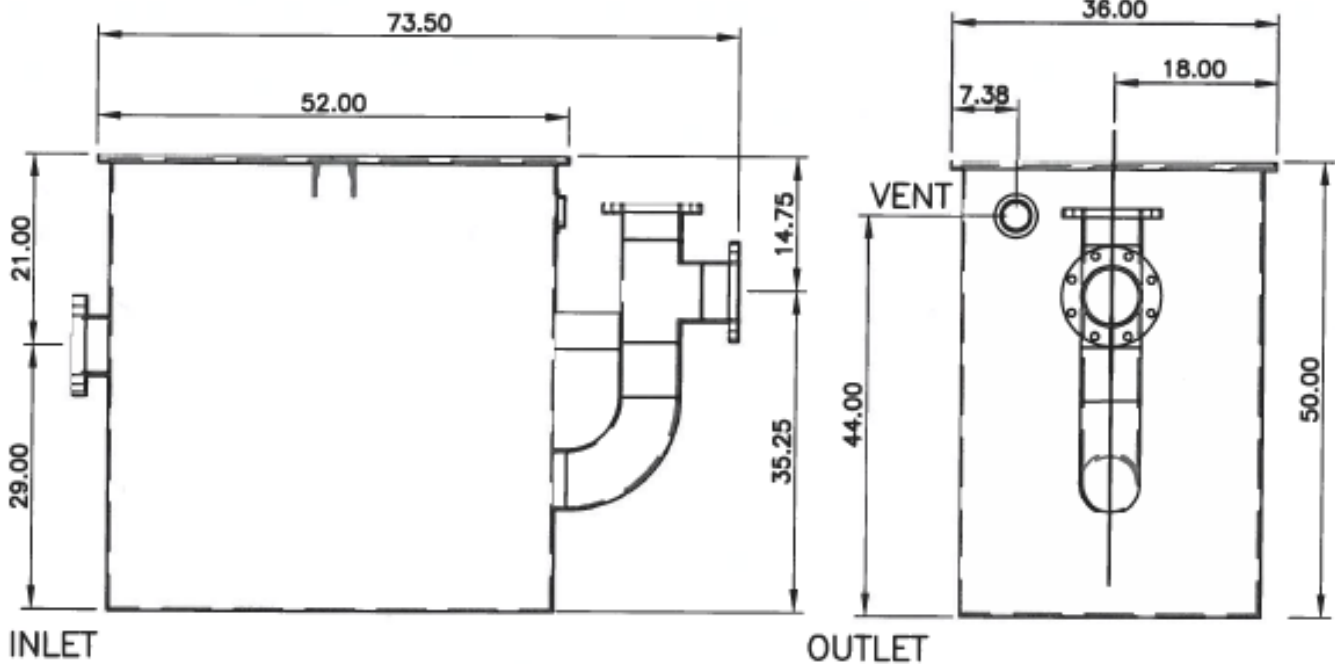
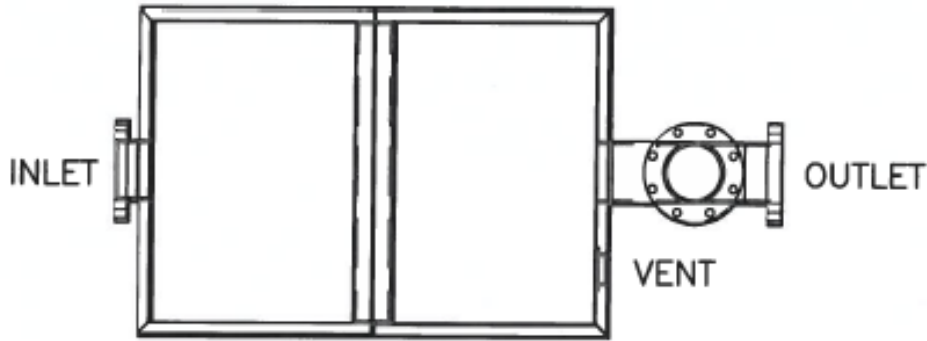

REQUIRES APPROVAL BY DWSO

Specifications

All welded 1/4" steel separator, 225 gallon static capacity, 6.00" companion flange inlet/outlet with 3.00" tapped internal vent connection, 500 lbs greasy sludge capacity, visible double-wall outside trap seal, separator plate and removable filter screen, removable 3/8" nonskid diamond treadplate covers for flush with floor installation suitable for pedestrian traffic secured with stainless flat head screws, heavy duty leak-proof gasket, OPEX Shop Coat coating inside and bituminous coating outside. Rockford Model GIS-70 or approved equivalent



DONALA WATER & SANITATION DISTRICT

GREASE SEPARATOR = 500 lbs.

DRAWN: GSM	REVISED: MAY 2018
DATE: JAN 2004	REVISED:
SCALE: NONE	REVISED:

WW-21

G:\DONALAINSTDSPECS\Sanitary\Dwg-22.dwg, 8.5x11, 5/3/2018 1:22:54 PM, sc, Xerox AltaLink C8035, 1:1

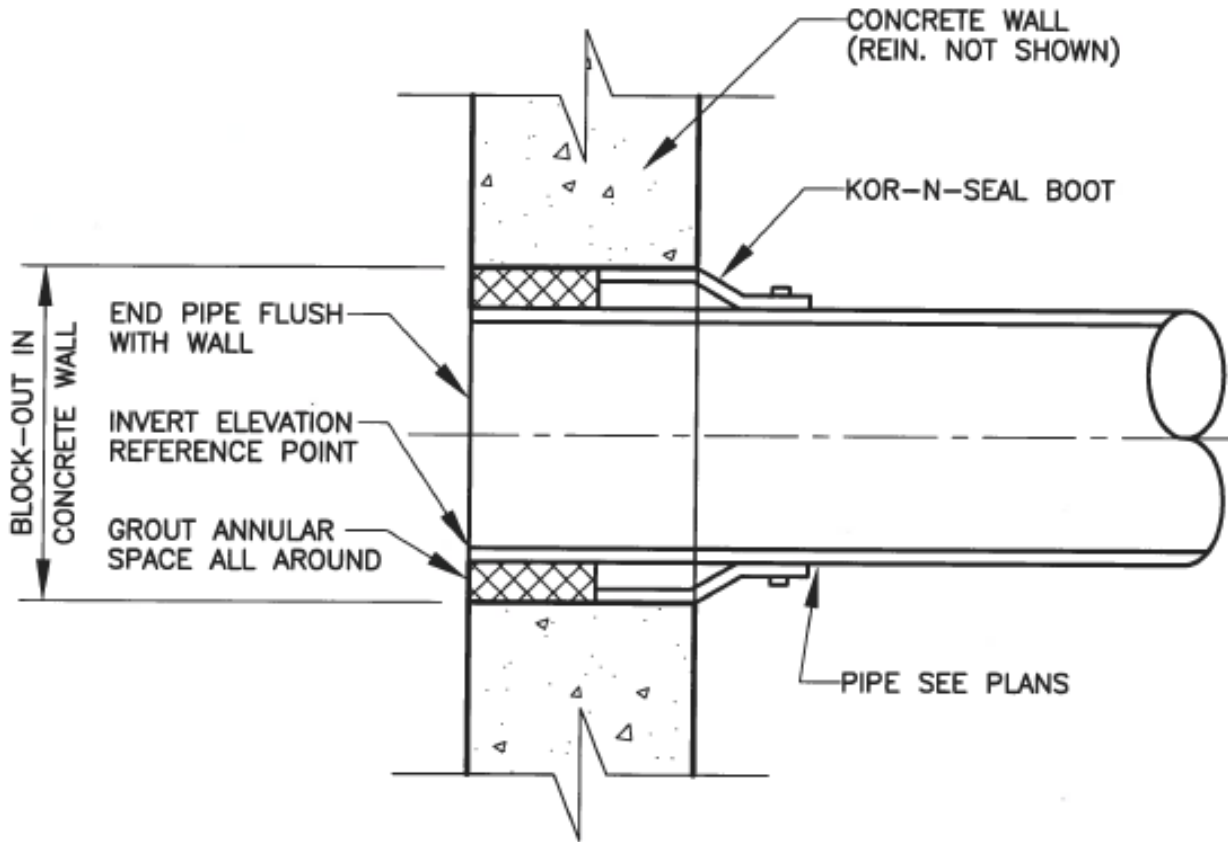

DONALA WATER & SANITATION DISTRICT

KOR-N-SEAL BOOT DETAIL

DRAWN: GSM	REVISED:
DATE: JAN 2004	REVISED:
SCALE: NONE	REVISED:

WW-22

PART III

EARTHWORK STANDARD SPECIFICATIONS

Chapter 1 - General

- 1.01 **Authority.** These Specifications are promulgated by the Donala Water and Sanitation District. The interpretation, enforcement, and revision of these Specifications is hereby delegated to the Superintendent of the District.
- 1.02 **Effective Date of Specifications.** These Specifications shall be in effect fifteen (15) calendar days after adoption by the District board and shall supersede all former standard specifications for earthwork within the District.
- 1.03 **Revisions, Amendments or Additions.** These Specifications may be revised, amended or added to. Such revisions, amendments and additions shall be binding and in full force and effect when adopted in the manner set forth in Section 1.02.
- 1.04 **District Control.** These Specifications will apply to the installation of water and wastewater facilities under the control of the Donala Water and Sanitation District.
- 1.05 **Organization and Interpretation of Specifications.** These Specifications are composed of written Standards of Engineering Practice, Material Specifications and Standard Drawings. The interpretation of any section or of differences between sections, when appropriate, shall be made by the Superintendent of the District and his/her interpretation shall be binding and controlling in its application.
- 1.06 **Definitions.** As used in these Specifications, or in any of the drawings where these Specifications govern, unless the context shall otherwise require, the following words defined shall have the meanings herein ascribed:
- a. **Superintendent.** The Superintendent of the District or his/her designated representative.
 - b. **Engineer.** The Engineer or consultant of the District, acting either directly or through properly authorized agents, such agents acting within the scope of the particular duties entrusted to them.
 - c. **Collection or Distribution System.** Sanitary sewer and potable water mains, together with all appurtenant and necessary valves, hydrants, taps, meters, service pipes, manholes and associated materials, property and equipment collecting sanitary sewer from or distributing potable water to individual customers.
 - d. **Pipe or Main.** That portion of the water supply system which transmits and distributes water of the District from treatment or storage facilities to users and/or the sanitary sewage collection system which collects wastewater from the user extending to the wastewater treatment plant, excluding service lines.

- e. Service Line. The sanitary sewer or water line extending from the premises up to and including the connection to the collection or distribution main as appropriate.
- f. Contractor. In the context of these Specifications a person or persons, co-partnership or corporation employed by an applicant for the purpose of installing sanitary sewage collection or water system extensions or replacements.
- g. Inspector. The authorized representative of the District assigned to the project.
- h. Standard Drawings. District Standard Drawings are a part of these Specifications.

1 .07 Abbreviations. All references to documents or specifications shall be the latest edition or revision thereof:

- | | | |
|----|------|---|
| a. | ASTM | American Society for Testing and Materials |
| b. | AWWA | American Water Works Association |
| c. | ANSI | American National Standards Institute |
| d. | NSF | National Sanitation Foundation |
| e. | OSHA | Occupational Safety and Health Administration |
| f. | USGS | United States Geological Survey |
| g. | CIP | Cast Iron Pipe |
| h. | DIP | Ductile Iron Pipe |
| i. | PVC | Polyvinyl Chloride-Plastic Pipe |
| j. | psi | Pounds per Square Inch |
| k. | PPM | Parts per Million |
| l. | PRV | Pressure Reducing Valve |

EARTHWORK STANDARD SPECIFICATIONS

Chapter 2 - Trenching, Backfilling and Compacting

2.01 General Provisions

- a. Unless otherwise indicated on the drawings, all excavations shall be made by open cut. Provisions for installation of potable water and/or sanitary sewer pipelines and appurtenances in other than open cut conditions shall be specifically detailed in the drawings and contract documents for the project.
- b. The Contractor and/or Developer shall be responsible for obtaining all permits necessary to accomplish the work. This includes all permits by any local general purpose governing agency relative to excavation and construction within public right-of-way, permits required by state highway agencies, permits required by railroad and other utility agencies and permits required by the State of Colorado, Water Quality Control Division including necessary site approvals, if appropriate.
- c. All work to be accomplished shall be done under the review and inspection of District representatives. Notification to the District shall be made by the Contractor and/or Developer indicating proposed schedules and times of work. Work accomplished without notification and review of the District's representatives may not be acceptable to the District. It shall be the responsibility of the Owner/Developer to adequately demonstrate to the District that all facilities have been constructed in accordance with the rules and regulations of the District.
- d. All rules and regulations of the District shall be applicable to all construction and operation of potable water and/or sanitary sewerage facilities within the boundaries of the District and those which are proposed for acceptance by annexation to the District. These rules and regulations shall be supplemented by all rules and regulations of the State of Colorado, Water Quality Control Division, in so far as they do not conflict with these rules and regulations. Any conflict shall be governed by an interpretation and ruling by the Superintendent, whose decision shall be final.
- e. Earthwork shall include all clearing, grubbing, grading, excavation, fill, backfill, excess excavation, bedding material, borrow material, and surface restoration as may be required to complete the work.

2.02 Job Conditions

a. Protection of Existing Facilities

(1) Surface Improvements

The Contractor shall protect from damage or restore to their original condition all surface improvements encountered during trenching or construction. Said improvements shall include but not be limited to the following: surfacing; sidewalks; curbs; valley gutters; trees and shrubs; other surface vegetation; driveways; mailboxes; utilities; signs; or other improvements.

(2) Underground Utilities and Obstructions

The Contractor shall protect from damage any underground pipes, utilities or structures encountered during construction. Restore any damaged underground obstructions to their original condition at no cost to the District unless evidence of other arrangements satisfactory to all parties is presented to the District.

Before commencing work, obtain information concerning location, type and extent of concealed existing utilities on the site and adjacent properties. Consult records and personnel of local utility companies, municipal utility department and telephone company. File Notice of Excavation with these agencies prior to commencing work.

(3) Underground obstructions known to exist, except service lines, are to be shown on the drawings or otherwise referred to in the specification. The locations shown may prove to be inaccurate and other obstructions not shown may be encountered. In any case, it shall be the responsibility of the Contractor to protect or restore all underground obstructions encountered.

b. Sheeting, Shoring, and Bracing. Except where trench banks are cut back on a stable slope, provide and maintain all sheeting necessary to protect adjoining grades and structures from caving, sliding, erosion or other damage and suitable forms of protection against bodily injury all in accordance with applicable codes and governing authorities. Comply with the most recent standards adopted by the Occupational Safety and Health Administration (OSHA). Do not remove any sheeting unless the pipe strength is sufficient to support the trench loads based on trench width measured to the back of sheeting. Remove sheeting and shoring as excavations are backfilled in a manner to protect the construction or other structures, utilities or property. Do not remove any sheeting after backfilling.

- c. Blasting. In general, blasting will be allowed in order to expedite the work if a permit by the local authority having jurisdiction is granted and a copy presented to the District. All explosives and appurtenances shall be transported, handled, stored and used in accordance with the laws of the local, state and federal governments, as applicable.

All blasting shall be controlled so as not to injure any existing structure or facility. The protection of life and property and all liability for blasting shall be placed solely on the person or persons conducting the blasting operation. The hours of blasting shall be fixed by the Inspector in accordance with the permit of the local authority. Owners or occupants of nearby structures or facilities, must be notified by the Contractor at least 72 hours in advance of blasting, in writing. The notice shall state the date, the time of blasting and who is responsible for the blasting. The District shall be notified a minimum of 48 hours in advance of any blasting.

Blasting shall be controlled to avoid making any excavation unduly large or irregular and so as not to shatter the rock on the bottom or sides of any excavation or surface upon or against which concrete is to be placed. If, in the opinion of the District, blasting is liable to damage rock foundations or supports, concrete, other utilities or structures, all blasting shall be terminated and excavation shall be continued by hammering, boring, wedging or other methods.

- d. Drainage. Maintain the excavations and site free from water throughout the work. Remove any water encountered in the trench to the extent necessary to provide firm subgrade, to permit joints to be made dry at the final grade and to prevent entrance of water into the pipeline. Accomplish the foregoing by the use of sumps and gravel blankets, well points, drain lines or other means approved by the District.
- e. Interruption of Service. Coordinate interruptions of utility services with the District or utility owner as appropriate. Make connections to the existing system requiring the interruption of service during the time designated by the District or utility owner.

Obtain permission to cut and replace existing service lines to facilitate trenching. Notify affected users a minimum of two hours in advance of, and restore service within four hours after any interruption. Repair all lines at no cost to the District unless otherwise provided for.

- f. Detours and Other Traffic Controls. When construction operations are located within streets make provisions at cross streets and walks for free passage of vehicles and pedestrians by bridging or other approved methods. Do not block streets or walks without prior approval.

Maintenance of access through the construction site by the traveling public shall be maintained by the contractor unless a street closure is approved in writing by the District or other governing authority. Access to all abutting residences and properties shall be maintained to the maximum extent possible. It shall be the responsibility of the Contractor and/or Developer to coordinate access to all adjacent private properties with the respective owners.

To protect persons from injury and to avoid property damage, adequate barricades, construction signs, safety flasher lights and guards as required shall be placed and maintained during the progress of the construction work and until it is safe for traffic to use the roadway. All material piles, equipment and pipe that may serve as obstructions to traffic shall be enclosed by fences or barricades and shall be protected by proper lights when the visibility is poor. All safety and traffic rules and regulations of local authorities shall be observed. All barricading and detours shall be coordinated as appropriate with the Donala Water and Sanitation District, El Paso County and/or the Colorado Department of Transportation and shall be in accordance with their regulations. Controls shall be in accordance with the "American Traffic Safety Services Association Guide," latest edition.

Should the District be contacted regarding a failure to properly barricade a construction area and the responsible Contractor cannot be contacted, the District shall set the necessary barricades at the Contractor's expense.

The Contractor shall carry on the work in a manner that will cause the least interruption in traffic and may close to through travel, not more than two (2) consecutive blocks, including the cross street intersected when so approved by the District. Where traffic must cross open trenches, the Contractor shall provide suitable bridges at street intersections and driveways. The Contractor shall post, where directed by the District, suitable signs indicating that a street or a portion of a street is closed and necessary detour signs for the proper maintenance of traffic.

- g. Sequencing. Pipeline installation shall follow trench excavation within 50 lineal feet. Trench backfill shall follow pipe installation within 50 lineal feet. Approved clean-up shall follow trench excavation with 200 linear feet.

2.03 Guarantee

- a. The Contractor and/or Developer shall guarantee all materials and workmanship for a period of one year from the date of initial acceptance by the District. Initial acceptance shall be made by the District's official written confirmation of acceptance.

- b. The guarantee shall include the maintenance of acceptable trench backfill for a period of one year from initial acceptance. Acceptable trench backfill shall include maintenance of an acceptable surface configuration matching surrounding grade or conforming to the finished street cross section. Removal and replacement of finished street surfacing due to excessive settlement shall be the responsibility of the Contractor and/or Developer within the one-year warranty period.

2.04 Products

- a. Embedment Materials. All water and sanitary sewer mains are to receive one of the following embedment materials extending from the bottom of the excavation to 12 inches over the pipeline.

- (1) Concrete. The pipeline embedment with concrete shall utilize concrete having a 28-day compressive strength of a minimum of 3000 psi and other characteristics as set forth in these Specifications.
- (2) Granular Material. Well-graded, crushed stone or gravel meeting the requirements of ASTM C33, Gradation 67 (3/4" to No.4).
- (3) Fine Granular Material. Natural or manufactured sand meeting the following requirements:

Well-Graded Sand

<u>Sieve Size</u>	<u>Total Percent Passing by Weight</u>
3/8 inch	100
No. 4 95 - 100	
No. 8 80 - 100	
No. 16	50 - 85
No. 30	25 - 60
No. 50	10 - 30
No. 100	2 - 10

- (4) Squeegee Sand

<u>Sieve Size</u>	<u>Total Percent Passing by Weight</u>
3/8 inch	100
No. 200	0 - 5

- (5) Selected Backfill. Selected soil free from rocks, clods or stones greater than 1-1/2" in any dimension as approved by the District's representative. Granular material, fine granular material or squeegee sand may be substituted for selected backfill.

b. Backfill Materials

- (1) Suitable Material. Soil obtained from the excavation that is free of frozen material, stumps, roots, brush, other organic matter, debris and other items. In addition, suitable material shall meet the following requirements:
- (2) Upper Portion of Trench. Material placed within one (1) foot of pavement subgrade or finished surface in unimproved areas shall be soil free from rocks, greater than 6 inches in nominal diameter.
- (3) Other Portions of Trench. Material within 6 inches below and 12 inches above the pipe shall contain particles of a size to conform to the embedment class required but in no case shall it contain rocks greater than 1-1/2 inches in any dimension. From a point 12 inches above the pipeline to within one (1) foot of the pavement subgrade or finished surface in unimproved areas, maximum size of any rock in the trench backfill shall be 18 inches nominal diameter.
- (4) Public Highways. Provide and install material in conformance with the Colorado Department of Transportation requirements where they do not conflict with other provisions of these regulations. Should a conflict exist, submit a request for clarification to the District in writing prior to proceeding with work.

2.05 Preparation of Trenching

- a. Construction Staking. All work shall be constructed in accordance with lines and grades shown on the drawings and as established by the Engineer-of-Record and/or District. These lines and grades may be modified by the Engineer-of-Record only after reapproval by the District.

Water facilities shall be staked in accordance with Part I, Chapter 2, Sections 2.09, 2.10 and 2.11. Sanitary sewer facilities shall be staked as follows.

Line and grade stakes shall be set for each manhole or other appurtenance and at each 25 foot station along the pipeline. When laser beam equipment is being utilized for alignment of the pipeline, construction stakes shall be set at each manhole and 25 feet, 50 feet and 75 feet and each 100 feet thereafter proceeding upstream from the manhole. The Contractor shall check the elevation at each grade stake and at intervals between stakes from a string line placed between the grade stakes. Should a variance from the design elevation be found, the pipeline shall be removed to a point where vertical and horizontal alignment is satisfactory and reconstructed in accordance with these specifications.

All facilities, equipment and assistance shall be furnished by the Contractor and/or Developer to facilitate checking alignment and grade of the pipe by the

District's representative and workmen involved in the construction.

- b. Pavement Removal. Before trenching begins, remove any pavement, curbs, gutters, sidewalks and other surface improvements necessary to install the pipeline and appurtenances.

Remove bituminous pavement to clean, straight lines at locations necessary to accommodate the work. Width of removal for pipelines shall be kept to a minimum as dictated by trenching operations but shall extend 6 inches to 12 inches beyond limits of trench excavation. Make pavement cuts with spade-bitted air hammer, saw or other approved method so to provide a straight and square edge. Should a cut edge become damaged during the course of construction, the edge will be recut prior to placement of surfacing material.

Remove concrete surfacing materials to neatly sawed edges with sawcuts made to a minimum depth of 1-1/2 inches or as otherwise required to neatly remove surfacing materials.

Make sawcuts in straight lines and at right angles to the alignment of sidewalks or curb and gutter. If the sawcut should fall within 30 inches of an existing construction joint, expansion joint or edge, the concrete shall be removed to the joint or edge.

- c. Clearing. Remove all stumps, roots, brush, other vegetation and debris from areas that will be disturbed by the construction operations.
- d. Sod Removal. In lawn areas, cut and roll back sod before trenching. Store sod for reinstallation after completion of backfilling operations.

- e. Topsoiling. Strip existing topsoil from areas to be disturbed by construction operations. Stockpile in areas designated by the Engineer-of-Record. Keep topsoil segregated from non-organic trench excavation materials and debris.

2.06 Excavation - Open Cut

- a. Caution in Excavation. The Contractor shall proceed with caution in the excavation and preparation of the trench so that the exact location of underground utilities and structures, both known and unknown, may be determined, and he/she shall be held responsible for the repair of such structures when broken or otherwise damaged because of carelessness on his/her part.
- b. Exploratory Excavation. Whenever, in the opinion of the District, it is necessary to explore and excavate to determine the location of underground utilities and structures that may interfere with construction, the Contractor shall make the explorations and excavations for such purposes.
- c. Limitation of Disturbed Area. The area disturbed by construction activities shall be confined within the construction limits as shown on the plans. The length of trench to be opened at any one time shall be limited in accordance with the requirements of Part III, Section 3.02.g of these specifications.

- d. Drainage and Protection. The sides of the trench shall be sloped or braced and the trench drained so that workmen can work safely and efficiently. All work must be done in a dry trench and no water will be permitted to be discharged down the pipe previously laid. The discharge from pumping shall be laid to an approved natural drainage channel or other location to prevent drainage into the sanitary sewer facilities and damage to public or private property.

All pipe trenches or structure excavation shall be kept free from water during pipe laying and other related work. The method of dewatering shall provide for a completely dry foundation at the final lines and grades of the excavation.

Dewatering shall be accomplished by the use of well points, sump pumps, rock or gravel drains placed below subgrade foundations or subsurface pipe drains. All water shall be disposed of in a suitable manner without being a menace to public health or causing public inconvenience. No water shall be drained into other work being completed or under construction.

Discharge from dewatering shall be subject to the regulations and permit requirements of the Colorado Department of Public Health and Environment. The Contractor shall be solely responsible for full compliance with those requirements.

The dewatering operation shall continue until such time as it is safe to allow the water table to rise in the excavations. Pipe trenches shall contain enough backfill to prevent pipe flotation. When pipe is installed in a casing or tunnel longer than thirty (30) pipe diameters, the pipe inside and casing or tunnel shall be secured so flotation does not occur when the pipe is empty.

Water shall not be allowed to rise until any concrete has set and the forms have been removed. Water shall not be allowed to rise unequally against unsupported structural walls.

Pile material suitable for backfilling in an orderly manner a sufficient distance from banks of the trench to avoid overloading and prevent slides or cave-ins.

Remove and waste excavated materials not suitable or not required for backfilling from the site. All surplus excavation shall be removed from the job site and disposed of properly. If the surplus excavation is disposed of on private property, written permission shall be obtained from the owner of the property and a copy given to the District Inspector.

- e. Excavation to Grade. Accurately grade trench bottoms to provide uniform bearing and support for each section of pipe on undisturbed soil at every point along its entire length. Provide a smooth uniform surface in the pipe subgrade where bedding material will be placed. If the subgrade material is over-excavated more than 2 inches, backfill shall be accomplished with compacted granular material in accordance with the bedding requirements.

- f. Limiting Trench Widths. Excavate trenches to provide adequate working space and pipe clearance for proper pipe installation, jointing and embedment. Provide a minimum clearance of 6 inches on each side of the pipe for a pipe 12 inches in diameter or less and 8 inches for pipe between 14 inches and 30 inches in diameter. The maximum allowable width of trench at one (1) foot above the top of the pipe shall not be greater than the outside diameter of the pipe plus 24 inches for all sizes.
- g. Bell Holes. Dig bell holes and depressions for joints after the trench bottom has been brought to final grade. Bell holes and depressions shall be only of such length, depth and width as required for properly making the particular type of joint. The use of earth mounds for bedding the pipe and adjusting for grade shall not be allowed.
- h. Preparation of Pipe Bearing Areas. Shape the pipe subgrade or bedding material to provide a continuous uniform bearing support at all points along its length except at required bell holes.
- i. Pipe Clearance in Rock. Where rock excavation is necessary, over excavate the trench bottom a minimum of 6 inches below the bottom of the pipe for pipe 24 inches in diameter or less and 9 inches for pipe larger than 24 inches. Backfill over depths with granular material specified.
- j. Excavation for Structures. Except as otherwise dictated by construction conditions, the excavation shall be of such dimensions as to allow for the proper installation and removal of concrete forms, or precast structures, and to permit the construction of the necessary pipe connections. Care shall be taken to insure that the excavation does not extend below established grades. If excavation is made below such grades, the resulting excess excavation shall be filled in with approved material deposited in horizontal layers not more than 6 inches in thickness, after being compacted, as directed by the District.
- k. Unstable Pipe Subgrade. If the bottom of the excavation at subgrade is found to be soft or unstable or to include ashes, cinders, refuse, vegetation or other organic material, or large pieces or fragments of inorganic material that, in the opinion of the inspector, cannot satisfactorily support the pipe or structure, the Contractor shall further excavate and remove such unsuitable material to the width and depth specified by the Inspector. Before the pipe or structure is installed, the subgrade shall be made as specified by the District.

Where the bottom of the trench at subgrade is found to consist of material that is unstable to such a degree that, in the opinion of the District, it cannot be removed and replaced with an approved material which will support the pipe or structure properly, the Contractor shall be required to construct a special foundation or support for the pipe or structure, consisting of pilings, timbers, or other materials, as specified by the District.

2.07 Pipe Embedment

- a. Placement of Embedment Material. Embedment material shall be placed in the trench on prepared subgrade in accordance with the requirements of these specifications. The embedment material shall be brought to a density beneath the proposed pipeline as required herein. The embedment material shall be shaped to conform to a cylindrical surface with a radius equal to the radius of the outside of the pipe with a width sufficient to allow 60% of the width of the pipe barrel to be uniformly supported by the bedding. Bedding material shall then be placed in two lifts, each being compacted to the densities specified herein to a depth of 1 foot above the top of the pipe.

- b. Embedment Classes. (See Drawing 1 of Part II - applicable for all pipelines.)

Class A - Concrete Cradle or Arch.

(1) Concrete Cradle

The pipe shall be bedded in a monolithic cradle of plain or reinforced concrete as specified on drawings, having a minimum thickness of one-fourth the inside pipe diameter or a minimum of 4 inches under the barrel and extending up the sides for a height equal to one-fourth the outside diameter. The cradle shall have width at least equal to the outside diameter of the pipe barrel plus 8 inches. Backfill above the cradle and extending to 12 inches above the crown of the pipe shall be compacted carefully.

(2) Concrete Arch

The pipe shall be embedded in carefully compacted granular material having a minimum thickness of one-fourth the outside diameter between barrel and bottom of trench excavation and extending halfway up the sides of the pipe. The top half of the pipe shall be covered with reinforced concrete arch having a minimum thickness of one-fourth the inside diameter of the crown and having a minimum width equal to the outside pipe diameter plus 8 inches.

Class B - Granular Bedding.

Granular material or fine granular material selected based on trench conditions encountered. Place as described in Section 2.07.a and compact in accordance with trench backfill requirements. If select backfill is not readily available for the upper portion of the bedding requirement, granular material may be substituted.

Class C

Select backfill material placed as described in Section 2.07.a and compacted.

Class D - Impermissible bedding condition.

2.08 Trench Backfilling and Compacting

- a. Place backfilled material above embedment materials in a manner to prevent damage or misalignment of the pipeline. Place in lifts of a thickness necessary to acquire the specified backfill density or in conformance with other regulatory requirements. Backfilled material shall conform to the requirements of Part III-Section 2.04.b of these specifications.
- b. Backfill Density Requirements. Unless otherwise specified or required by local governing authority, all backfill should be placed in a manner to achieve the density specified below.
 - (1) State Highway
100% of maximum in paved and shoulder areas
95% of maximum in all other areas
 - (2) Paved roadways, sidewalks and other areas to receive pavement
95% of maximum density for entire trench depth
 - (3) Gravel roadways
95% of maximum density for entire trench depth
 - (4) Sodded or lawn areas over a dedicated easement or right-of-way
90% of maximum density
 - (5) Zone 6" below to 12" above pipe
95% of maximum density for all pipelines

Where another governing agency having jurisdiction over work within a road right-of-way has specifications requiring a greater backfill density, the requirements of the more stringent specification shall apply.

- c. Method of Compaction. In general, backfill shall be mechanically compacted by means of tamping rollers, sheep foot rollers, pneumatic tire rollers, vibrating rollers and other mechanical tampers.

Compaction by jetting shall not be permitted unless material is of suitable granular material as determined by the District. In no case will compaction by jetting be permitted in state highways or paved or gravel roadways.

- 2.09 Backfill for Structures. Backfill and fill within 3 feet adjacent to all structures and for full height of the walls shall be selected non-swelling material. It shall be relatively impervious, well graded, and free from stones larger than 3 inches. Material may be job excavated, but selectivity will be required.

No backfilling will be allowed in freezing weather except by permission of the District. No additional backfill will be allowed over any frozen material already in the trench.

All water required for backfill and compaction operations can be furnished from a designated fire hydrant near the project. The Contractor will be charged in accordance with the current cost for construction water. However, the Contractor will be responsible for furnishing all required personnel, valving, hose and other equipment needed to deliver the water to the desired location on the project. The District will designate the fire hydrant to be used and must be notified when water is required.

- 2.10 Field Quality Control

- a. Density Testing and Control. Density testing as may be required by the District's representatives shall be the responsibility of the Contractor and/or Developer. Results of such density testing shall be reported directly to the District by the testing agency. All reports shall be submitted with the seal and signature of a registered professional engineer experienced in the testing of soil materials.
- b. Soil Compaction Tests. Conduct in accordance with the requirements of ASTM C698-70 or AASHTO T99, "Standard Method of Test for Moisture Density Relations of Soils Using a 5.5 lb. Rammer and a 12 inch Drop." Use method A, B, C or D as appropriate on soil condition and judgment of the testing laboratory. Samples tested shall be representative of materials to be placed (or altered). Obtain optimum moisture density curve for each type of material or combination of materials encountered or utilized. Use test results as a basis for compaction control. Testing includes Atterberg Limits, grain size determination and specific gravity.

Density Control

Conduct tests for density control during compaction operations in accordance with the requirements of:

ASTM D2922 - Tests for Density of Soil and Soil - Aggregate In-Place by Nuclear Methods

ASTM D1556 - Tests for Density of Soil and Soil - Aggregate In-Place by the Sand Cone Method

OR

ASTM C2167 - Test for Density of Soil In-Place by the Rubber-Balloon Method

- c. Test Frequency. The District representative shall determine the location of all density testing to be accomplished. As a minimum, three tests at three (3) different levels for every 1,000 lineal feet of trench shall be performed. The tests shall be taken approximately one foot above the pipe, mid-trench depth and within the top one foot of the trench. The Contractor and/or Developer shall excavate backfilled material to the depths directed by the District representative to accommodate the testing and backfill test holes in accordance with these regulations.

- 2.11 Surface Restoration. Fine grade all areas disturbed by the construction operations after completion of backfilling and compacting. Areas which are to receive pavements, surfacing, topsoil or landscaping shall be graded as required to allow installation of the specific surface treatment. Grade all other areas to match the existing ground line.

Replace suitable topsoil to the depth of stripping over all areas disturbed by the construction that do not receive other surface treatment. Do not compact topsoil during stripping, stockpiling or placing.

The Contractor shall restore all pavement, sidewalks, curbing, gutters or other surface structures removed or disturbed as part of the work to a condition meeting the standards of the governing agency, and shall furnish all incidental labor and materials. No permanent pavement shall be restored until, in the opinion of the District or agency having control, the condition of backfill is such as to properly support the pavement.

If any pavement, street, shrubbery, sod, rock, fences, poles or other property and surface structures have been damaged, removed or disturbed by the Contractor, whether deliberately or through failure to carry out the requirements of the controlling agency or the specific directions of the District, or through failure to employ usual and reasonable safeguards, such property and surface structures shall be replaced or repaired, to the satisfaction of the owner, at the expense of the Contractor.

- 2.12 Surface Improvement Repair and Restoration. Replace and repair any surface improvements damaged or removed. Meet the requirements specified for the particular type of improvements to be repaired or replaced. All surface improvements shall meet the requirements of the local governing agency and/or the requirements shown on the contract drawings as approved by the District.

2.13 Cleanup. Upon completion of the work, all rubbish, unused materials, concrete forms and other like materials shall be removed from the jobsite. All excess excavation shall be disposed of as specified and the areas shall be left in a state of order and cleanliness.